

MATH 217/317—Advanced Honors Calculus, I and II  
(Winter, 2023)

*Volker Runde and John C. Bowman*

April 18, 2023

# Contents

<b>Introduction</b>	<b>5</b>
<b>List of Symbols</b>	<b>6</b>
<b>1 Topology in <math>\mathbb{R}^N</math></b>	<b>8</b>
1.1 The Real Line . . . . .	8
1.2 Functions . . . . .	20
1.3 The Euclidean Space $\mathbb{R}^N$ . . . . .	24
1.4 Topology . . . . .	31
<b>2 Limits and Continuity</b>	<b>48</b>
2.1 Limits of Sequences . . . . .	48
2.2 Limits of Functions . . . . .	55
2.3 Global Properties of Continuous Functions . . . . .	58
2.4 Uniform Continuity . . . . .	63
<b>3 Differentiation in <math>\mathbb{R}^N</math></b>	<b>66</b>
3.1 Differentiation in One Variable: A Review . . . . .	66
3.2 Partial Derivatives . . . . .	70
3.3 Vector Fields . . . . .	75
3.4 Total Differentiability . . . . .	79
3.5 Taylor's Theorem . . . . .	87
3.6 Classification of Stationary Points . . . . .	91
<b>4 Integration in <math>\mathbb{R}^N</math></b>	<b>97</b>
4.1 Content in $\mathbb{R}^N$ . . . . .	97
4.2 The Riemann Integral in $\mathbb{R}^N$ . . . . .	100
4.3 Evaluation of Integrals in One Variable: A Review . . . . .	113
4.4 Fubini's Theorem . . . . .	116
4.5 Integration in Polar, Spherical, and Cylindrical Coordinates . . . . .	123

<b>5</b>	<b>Properties of <math>\mathcal{C}^1</math>-Functions and Applications</b>	<b>133</b>
5.1	Local Properties of $\mathcal{C}^1$ -Functions . . . . .	133
5.2	The Implicit Function Theorem . . . . .	137
5.3	Local Extrema under Constraints . . . . .	144
5.4	Change of Variables . . . . .	151
<b>6</b>	<b>Curve and Surface Integrals</b>	<b>166</b>
6.1	Curves in $\mathbb{R}^N$ . . . . .	166
6.2	Curve Integrals . . . . .	176
6.3	Green's Theorem . . . . .	189
6.4	Surfaces in $\mathbb{R}^3$ . . . . .	196
6.5	Introduction to Differential Forms . . . . .	201
6.6	Surface Integrals and Stokes' Theorem . . . . .	204
6.7	Gauß' Theorem . . . . .	209
<b>7</b>	<b>Stokes' Theorem for Differential Forms</b>	<b>216</b>
7.1	Alternating Multilinear Forms . . . . .	216
7.2	Differential Forms . . . . .	221
7.3	Integration of Differential Forms . . . . .	228
7.4	Simplices and Chains . . . . .	231
7.5	Stokes' Theorem . . . . .	238
<b>8</b>	<b>Infinite Series and Improper Integrals</b>	<b>243</b>
8.1	Infinite Series . . . . .	243
8.2	Improper Riemann Integrals . . . . .	258
<b>9</b>	<b>Sequences and Series of Functions</b>	<b>267</b>
9.1	Uniform Convergence . . . . .	267
9.2	Power Series . . . . .	272
9.3	Fourier Series . . . . .	282
9.4	Uniform Convergence of Improper Integrals . . . . .	297
<b>A</b>	<b>Linear Algebra</b>	<b>300</b>
A.1	Linear Maps and Matrices . . . . .	300
A.2	Determinants . . . . .	303
A.3	Eigenvalues . . . . .	306
<b>B</b>	<b>Limit Superior and Limit Inferior</b>	<b>310</b>
B.1	The Limit Superior . . . . .	310
B.2	The Limit Inferior . . . . .	312

*CONTENTS*

4

**Index**

**313**

# Introduction

The present notes are based on the courses MATH 217 and 317 as I taught them in 2004–2005 and 2016–2022. It is an updated (and debugged) version of previous incarnations of these notes. The most distinctive notion of this version is that it includes exercises. Also, some new material has been added to Sections 6.2 (on conservative vector fields) and 9.3 (Weierstraß' Approximation Theorem). An entirely new Chapter 7 has been inserted, which treats differential forms and puts the classical integral theorems of Green, Stokes, and Gauß into proper perspective.

The notes are not intended to replace any of the many textbooks on the subject, but rather to supplement them by relieving the students from the necessity of taking notes and thus allowing them to devote their full attention to the lecture.

Of course, the degree of originality conveyed in these notes is (very) limited. In putting them together, I mostly relied on the following sources:

1. JAMES S. MULDOWNEY, *Advanced Calculus Lecture Notes for Mathematics 217–317*. Third Edition. (available online);
2. ROBERT G. BARTLE, *The Elements of Real Analysis*. Second Edition. Jossey-Bass, 1976;
3. OTTO FORSTER, *Analysis 2*. Vieweg, 1984;
4. HARRO HEUSER, *Lehrbuch der Analysis*, Teil 2. Teubner, 1983.

It ought to be clear that these notes may only be used for educational, non-profit purposes.

Volker Runde, Edmonton

December 7, 2022

Addendum: In 2023, John Bowman added hyperlinks, simplified the wording, fixed typographical errors, and made minor improvements to the proofs, along with adding a new section in Chapter 6 to motivate the wedge product before its first use.

# List of Symbols

- $\infty$ , 8  
 $-\infty$ , 8  
 $|\cdot|$ , 17, 88  
 $\|\cdot\|$ , 25  
 $\|\cdot\|_2$ , 284  
 $\|\|\cdot\|\|$ , 301  
 $\oplus$ , 175, 232  
 $\sim$ , 231, 283  
 $\nabla f$ , 71  
  
 $(a, b)$ , 17  
 $[a, b]$ , 17  
 $(a, b]$ , 17  
 $[a, b)$ , 17  
 $a \times b$ , 197  
 $A_{\rho, R}$ , 131  
 $A^t$ , 308  
 $\alpha!$ , 88  
  
 $B_r(x_0)$ , 28  
 $B_r[x_0]$ , 28  
  
 $\operatorname{curl} v$ , 76  
 $\mathbb{C}$ , 9  
 $\mathcal{C}^0(U, \mathbb{R}^M)$ , 133  
 $\mathcal{C}^p(U, \mathbb{R}^M)$ , 133  
  
 $\det A$ , 303  
 $\operatorname{div} v$ , 76  
 $df$ , 223  
 $\frac{df}{dx}(x_0)$ , 66  
  
 $d\omega$ , 223  
 $D_j f(x_0)$ , 70  
 $Df(x_0)$ , 80  
 $D^\alpha f$ , 88  
 $D_n(t)$ , 287  
 $\Delta f$ , 77  
 $\frac{\partial f}{\partial x_j}(x_0)$ , 70  
 $\frac{\partial f}{\partial x_j}$ , 72  
 $\frac{\partial^2 f}{\partial x_k \partial x_j}$ , 72  
 $\frac{\partial^\alpha f}{\partial x^\alpha}$ , 88  
 $\partial S$ , 38  
 $\partial \Phi$ , 233  
 $\partial \Sigma$ , 232  
  
 $\exp(x)$ , 255  
  
 $f : A \rightarrow B, \quad x \mapsto f(x)$ , 20  
 $f(X)$ , 20  
 $f^{-1}(Y)$ , 20  
 $f^{-1} : A \rightarrow B$ , 21  
 $f'(x_0)$ , 66  
 $f_{x_j}(x_0)$ , 70  
 $\mathbb{F}$ , 8  
 $\mathbb{F}[X]$ , 9  
 $\mathbb{F}(X)$ , 9  
 $\{\Phi\}$ , 196, 228  
 $\llbracket \Phi \rrbracket$ , 233  
  
 $\operatorname{grad} f$ , 71  
 $\{\gamma\}$ , 166

- Hess  $f$ , 90  
 $\chi_A$ , 307  
 inf  $S$ , 14  
 int  $S$ , 40  
 $J_f(x_0)$ , 80  
 $\lim_{n \rightarrow \infty} x_n = x$ , 48  
 $\lim_{x \rightarrow x_0} f(x) = L$ , 55  
 $\limsup_{n \rightarrow \infty} a_n$ , 311  
 $\liminf_{n \rightarrow \infty} a_n$ , 312  
 $\Lambda^r(\mathbb{R}^N)$ , 219  
 $\Lambda^r(\mathcal{C}^p(U))$ , 221  
 $M_N(\mathbb{R})$ , 80  
 $M_N(\mathbb{C})$ , 306  
 $\mu(I)$ , 97  
 $\mu(S) = 0$ , 97  
 $\mu(D)$ , 107  
 $\mu_N(D)$ , 108  
 $\mathbb{N}$ , 9  
 $\mathbb{N}_0$ , 22  
 $\omega_1 \wedge \cdots \wedge \omega_r$ , 219  
 $\omega \wedge \phi$ , 221, 222  
 $\omega_T$ , 226  
 $\mathcal{PC}_\omega(\mathbb{R})$ , 282  
 $\mathfrak{P}(S)$ , 24  
 $\mathbb{Q}$ , 9  
 rank  $A$ , 134  
 $\mathbb{R}$ , 8  
 $\mathbb{R}^N$ , 24  
 sgn  $\sigma$ , 217, 303  
 sup  $S$ , 14  
 $\overline{S}$ , 39  
 $S_r[x_0]$ , 38  
 $S_1 \times \cdots \times S_N$ , 24  
 $S(f, \mathcal{P})$ , 101  
 $S_n(f)$ , 287  
 $\mathfrak{S}_r$ , 217, 303  
 $\Sigma_N$ , 231  
 $\sum_{k=1}^{\infty} a_k$ , 243  
 $\int_I f$ , 102  
 $\int_I f d\mu$ , 102  
 $\int_I f(x_1, \dots, x_N) d\mu(x_1, \dots, x_N)$ , 102  
 $\int_D f$ , 107  
 $\int_\gamma f \cdot dx$ , 177  
 $\int_\gamma f_1 dx_1 + \cdots + f_N dx_N$ , 177  
 $\int_{\Phi} P dy \wedge dz + Q dz \wedge dx + R dx \wedge dy$ , 204  
 $\int_{\Phi} \omega$ , 228, 238  
 $\int_{\Phi} f d\sigma$ , 204  
 $\int_a^{\infty} f(x) dx$ , 258  
 $\int_{-\infty}^b f(x) dx$ , 258  
 $\int_{-\infty}^{\infty} f(x) dx$ , 259  
 $T_A$ , 300  
 $\wedge$ , 203  
 $x \cdot y$ , 25  
 $x_n \xrightarrow{n \rightarrow \infty} x$ , 48  
 $x_n \rightarrow x$ , 48  
 $x^\alpha$ , 88  
 $[x, y]$ , 183  
 $[x_0, x_1, \dots, x_r]$ , 231  
 $\llbracket x_0, x_1, \dots, x_r \rrbracket$ , 232  
 $\mathbb{Z}$ , 10

# Chapter 1

## Topology in $\mathbb{R}^N$

### 1.1 The Real Line

What is  $\mathbb{R}$ ?

Intuitively, one can think of  $\mathbb{R}$  as of a line stretching from  $-\infty$  to  $\infty$ . Intuition, however, can be deceptive in mathematics. In order to lay solid foundations for calculus, we introduce  $\mathbb{R}$  from an entirely formalistic point of view: we demand from a certain set that it satisfies the properties that we intuitively expect  $\mathbb{R}$  to have, and then just define  $\mathbb{R}$  to be this set!

What are the properties of  $\mathbb{R}$  we need to do mathematics? First of all, we should be able to do arithmetic.

**Definition 1.1.1.** A *field* is a set  $\mathbb{F}$  together with two binary operations  $+$  and  $\cdot$  satisfying the following:

- (F1) for all  $x, y \in \mathbb{F}$ , we have  $x + y \in \mathbb{F}$  and  $x \cdot y \in \mathbb{F}$  as well;
- (F2) for all  $x, y \in \mathbb{F}$ , we have  $x + y = y + x$  and  $x \cdot y = y \cdot x$  (*commutativity*);
- (F3) for all  $x, y, z \in \mathbb{F}$ , we have  $x + (y + z) = (x + y) + z$  and  $x \cdot (y \cdot z) = (x \cdot y) \cdot z$  (*associativity*);
- (F4) for all  $x, y, z \in \mathbb{F}$ , we have  $x \cdot (y + z) = x \cdot y + x \cdot z$  (*distributivity*);
- (F5) there are  $0, 1 \in \mathbb{F}$  with  $0 \neq 1$  such that for all  $x \in \mathbb{F}$ , we have  $x + 0 = x$  and  $x \cdot 1 = x$  (*existence of neutral elements*);
- (F6) for each  $x \in \mathbb{F}$ , there is  $-x \in \mathbb{F}$  such that  $x + (-x) = 0$ , and for each  $x \in \mathbb{F} \setminus \{0\}$ , there is  $x^{-1} \in \mathbb{F}$  such that  $x \cdot x^{-1} = 1$  (*existence of inverse elements*).

Items (F1) to (F6) in Definition 1.1.1 are called the *field axioms*.



For the sake of simplicity, we use the following shorthand notation:

$$\begin{aligned} xy &:= x \cdot y; \\ x + y + z &:= x + (y + z); \\ xyz &:= x(yz); \\ x - y &:= x + (-y); \\ \frac{x}{y} &:= xy^{-1} \quad (\text{where } y \neq 0); \\ x^n &:= \underbrace{x \cdots x}_{n \text{ times}} \quad (\text{where } n \in \mathbb{N}); \\ x^0 &:= 1. \end{aligned}$$

*Examples.*

1.  $\mathbb{Q}$ ,  $\mathbb{R}$ , and  $\mathbb{C}$  are fields.
2. Let  $\mathbb{F}$  be any field then

$$\mathbb{F}(X) := \left\{ \frac{p}{q} : p \text{ and } q \text{ are polynomials in } X \text{ with coefficients in } \mathbb{F} \text{ and } q \neq 0 \right\}$$

is a field.

3. Define  $+$  and  $\cdot$  on  $\{A, B\}$  through the following tables:

+	A	B
A	A	B
B	B	A

and

·	A	B
A	A	A
B	A	B

This turns  $\{A, B\}$  into a field as is easily verified.

4. Define  $+$  and  $\cdot$  on  $\{\circ, \clubsuit, \heartsuit\}$ :

+	○	♣	♥
○	○	♣	♥
♣	♣	♥	○
♥	♥	○	♣

and

·	○	♣	♥
○	○	○	○
♣	○	♣	♥
♥	○	♥	♣

This turns  $\{\circ, \clubsuit, \heartsuit\}$  into a field as is also routinely verified.

5. Let

$$\mathbb{F}[X] := \{p : p \text{ is a polynomial in } X \text{ with coefficients in } \mathbb{F}\}.$$

Then  $\mathbb{F}[X]$  is not a field because, for instance,  $X$  has no multiplicative inverse.

6. Both  $\mathbb{Z}$  and  $\mathbb{N}$  are not fields.

There are several properties of a field that are not part of the field axioms, but which, nevertheless, can easily be deduced from them:

1. The neutral elements 0 and 1 are unique: Suppose that both  $0_1$  and  $0_2$  are neutral elements for  $+$ . Then we have

$$\begin{aligned} 0_1 &= 0_1 + 0_2, && \text{by (F5),} \\ &= 0_2 + 0_1, && \text{by (F2),} \\ &= 0_2, && \text{again by (F5).} \end{aligned}$$

A similar argument works for 1.

2. The inverses  $-x$  and  $x^{-1}$  are uniquely determined by  $x$ : Let  $x \neq 0$ , and let  $y, z \in \mathbb{F}$  be such that  $xy = xz = 1$ . Then we have

$$\begin{aligned} y &= y(xz), && \text{by (F5) and (F6),} \\ &= (yx)z, && \text{by (F3),} \\ &= (xy)z, && \text{by (F2),} \\ &= z(xy), && \text{again by (F2),} \\ &= z, && \text{again by (F5) and (F6).} \end{aligned}$$

A similar argument works for  $-x$ .

3.  $x0 = 0$  for all  $x \in \mathbb{F}$ .

*Proof.* We have

$$\begin{aligned} x0 &= x(0 + 0), && \text{by (F5),} \\ &= x0 + x0, && \text{by (F4).} \end{aligned}$$

This implies

$$\begin{aligned} 0 &= x0 - x0, && \text{by (F6),} \\ &= (x0 + x0) - x0, \\ &= x0 + (x0 - x0), && \text{by (F3),} \\ &= x0, \end{aligned}$$

which proves the claim. □

4.  $(-x)y = -xy$  holds for all  $x, y \in \mathbb{F}$ .

*Proof.* We have

$$xy + (-x)y = (x - x)y = 0.$$

Uniqueness of  $-xy$  then yields that  $(-x)y = -xy$ . □

5. For any  $x, y \in \mathbb{F}$ , the identity

$$(-x)(-y) = -(x(-y)) = -(-xy) = xy$$

holds.

6. If  $xy = 0$ , then  $x = 0$  or  $y = 0$ .

*Proof.* Suppose that  $x \neq 0$ , so that  $x^{-1}$  exists. Then we have

$$y = y(xx^{-1}) = (yx)x^{-1} = 0,$$

which proves the claim. □

Of course, Definition 1.1.1 is not enough to fully describe  $\mathbb{R}$ . Hence, we need to take properties of  $\mathbb{R}$  into account that are not merely arithmetic anymore:

**Definition 1.1.2.** An *ordered field* is a field  $\mathbb{O}$  together with a subset  $P$  with the following properties:

(O1) for  $x, y \in P$ , we have  $x + y \in P$  as well;

(O2) for  $x, y \in P$ , we have  $xy \in P$ , as well;

(O3) for each  $x \in \mathbb{O}$ , exactly one of the following holds:

(i)  $x \in P$ ;

(ii)  $x = 0$ ;

(iii)  $-x \in P$ .

Again, we introduce shorthand notation:

$$x < y \quad :\iff \quad y - x \in P;$$

$$x > y \quad :\iff \quad y < x;$$

$$x \leq y \quad :\iff \quad x < y \text{ or } x = y;$$

$$x \geq y \quad :\iff \quad x > y \text{ or } x = y.$$

As for the field axioms, there are several properties of ordered fields that are not part of the *order axioms* (Definition 1.1.2(O1) to (O3)), but follow from them without too much trouble:

1.  $x < y$  and  $y < z$  implies  $x < z$ .

*Proof.* If  $y-x \in P$  and  $z-y \in P$ , then (O1), implies that  $z-x = (z-y)+(y-x) \in P$  as well.  $\square$

2. If  $x < y$ , then  $x+z < y+z$  for any  $z \in \mathbb{O}$ .

*Proof.* This holds because  $(y+z) - (x+z) = y-x \in P$ .  $\square$

3.  $x < y$  and  $z < u$  implies that  $x+z < y+u$ .

4.  $x < y$  and  $t > 0$  implies  $tx < ty$ .

*Proof.* We have  $ty - tx = t(y-x) \in P$  by (O2).  $\square$

5.  $0 \leq x < y$  and  $0 \leq t < s$  implies  $tx < sy$ .

6.  $x < y$  and  $t < 0$  implies  $tx > ty$ .

*Proof.* We have

$$tx - ty = t(x-y) = -t(y-x) \in P$$

because  $-t \in P$  by (O3).  $\square$

7.  $x^2 > 0$  holds for any  $x \neq 0$ .

*Proof.* If  $x > 0$ , then  $x^2 > 0$  by (O2). Otherwise,  $-x > 0$  must hold by (O3), so that  $x^2 = (-x)^2 > 0$  as well.  $\square$

In particular  $1 = 1^2 > 0$ .

8.  $x^{-1} > 0$  for each  $x > 0$ .

*Proof.* This is true because

$$x^{-1} = x^{-1}x^{-1}x = (x^{-1})^2x > 0.$$

holds.  $\square$

9.  $0 < x < y$  implies  $y^{-1} < x^{-1}$ .

*Proof.* The fact that  $xy > 0$  implies that  $x^{-1}y^{-1} = (xy)^{-1} > 0$ . It follows that

$$y^{-1} = x(x^{-1}y^{-1}) < y(x^{-1}y^{-1}) = x^{-1}$$

holds as claimed.  $\square$

*Examples.*

1.  $\mathbb{Q}$  and  $\mathbb{R}$  are ordered.
2.  $\mathbb{C}$  cannot be ordered.

*Proof.* Assume that  $P \subset \mathbb{C}$  as in Definition 1.1.2 does exist. We know that  $1 \in P$ . On the other hand, we have  $-1 = i^2 \in P$ , which contradicts (O3).  $\square$

3.  $\{A, B\}$  cannot be ordered.

*Proof.* Assume that there is a set  $P$  as required by Definition 1.1.2. Since  $B \in P$  and  $A \notin P$ , it follows that  $P = \{B\}$ . But this implies  $A = B + B \in P$  contradicting (O1).  $\square$

Similarly, it can be shown that  $\{\heartsuit, \clubsuit, \spadesuit\}$  cannot be ordered.

The last two of these examples are just instances of a more general phenomenon:

**Proposition 1.1.3.** *Let  $\mathbb{O}$  be an ordered field. Then we can identify the subset  $\{1, 1 + 1, 1 + 1 + 1, \dots\}$  of  $\mathbb{O}$  with  $\mathbb{N}$ .*

*Proof.* Let  $n, m \in \mathbb{N}$  be such that

$$\underbrace{1 + \dots + 1}_{n \text{ times}} = \underbrace{1 + \dots + 1}_{m \text{ times}}.$$

Without loss of generality, let  $n \geq m$ . Assume that  $n > m$ . Then

$$0 = \underbrace{1 + \dots + 1}_{n \text{ times}} - \underbrace{1 + \dots + 1}_{m \text{ times}} = \underbrace{1 + \dots + 1}_{n - m \text{ times}} > 0$$

must hold, which is impossible. Hence, we have  $n = m$ .  $\square$

Hence, if  $\mathbb{O}$  is an ordered field, it contains a copy of the infinite set  $\mathbb{N}$  and thus has to be infinite itself. This means that no finite field can be ordered.

Both  $\mathbb{R}$  and  $\mathbb{Q}$  satisfy (O1), (O2), and (O3). Hence, (F1) to (F6) combined with (O1), (O2), and (O3) still do not fully characterize  $\mathbb{R}$ .

**Definition 1.1.4.** Let  $\mathbb{O}$  be an ordered field, and let  $\emptyset \neq S \subset \mathbb{O}$ . Then  $C \in \mathbb{O}$  is called:

- (a) an *upper bound* for  $S$  if  $x \leq C$  for all  $x \in S$  (in this case  $S$  is called *bounded above*);
- (b) a *lower bound* for  $S$  if  $x \geq C$  for all  $x \in S$  (in this case  $S$  is called *bounded below*).

If  $S$  is both bounded above and below, we simply call it *bounded*.

*Example.* The set

$$\{\bar{q} \in \mathbb{Q} : q \geq 0 \text{ and } q^2 \leq 2\}$$

is bounded below (by 0) and above by 2022.

**Definition 1.1.5.** Let  $\mathbb{O}$  be an ordered field, and let  $\emptyset \neq S \subset \mathbb{O}$ . Then:

- (a) an upper bound for  $S$  is called the *supremum* of  $S$  (in short:  $\sup S$ ) if  $\sup S \leq C$  for every upper bound  $C$  for  $S$ ;
- (b) a lower bound for  $S$  is called the *infimum* of  $S$  (in short:  $\inf S$ ) if  $\inf S \geq C$  for every lower bound  $C$  for  $S$ .

*Remark.* It is easy to see that, whenever a set has a supremum or an infimum, then they are unique.

*Example.* The set

$$S := \{q \in \mathbb{Q} : -2 \leq q < 3\}$$

is bounded such that  $\inf S = -2$  and  $\sup S = 3$ . Clearly,  $-2$  is a lower bound for  $S$  and since  $-2 \in S$ , it must be  $\inf S$ . Clearly,  $3$  is an upper bound for  $S$ ; if  $r \in \mathbb{Q}$  were an upper bound of  $S$  with  $r < 3$ , then

$$\frac{1}{2}(r+3) > \frac{1}{2}(r+r) = r$$

can not be in  $S$  anymore whereas

$$\frac{1}{2}(r+3) < \frac{1}{2}(3+3) = 3$$

implies the opposite. Hence,  $3$  is the supremum of  $S$ .

Do infima and suprema always exist in ordered fields? We shall soon see that this is not the case in  $\mathbb{Q}$ .

**Definition 1.1.6.** An ordered field  $\mathbb{O}$  is called *complete* if  $\sup S$  exists for every  $\emptyset \neq S \subset \mathbb{O}$  which is bounded above.

We shall use completeness to define  $\mathbb{R}$ :

**Definition 1.1.7.**  $\mathbb{R}$  is a complete ordered field.

It can be shown that  $\mathbb{R}$  is *the only* complete ordered field (see Exercise 1.2.1 below) even though this is of little relevance for us: the only properties of  $\mathbb{R}$  we are interested in are those of a complete ordered field. From now on, we shall therefore rely on Definition 1.1.7 alone when dealing with  $\mathbb{R}$ .

Here are a few consequences of completeness:

**Theorem 1.1.8.**  $\mathbb{R}$  is Archimedean, i.e.,  $\mathbb{N}$  is not bounded above.

*Proof.* Assume otherwise. Then  $C := \sup \mathbb{N}$  exists. Since  $C - 1 < C$ , it is impossible that  $C - 1$  is an upper bound for  $\mathbb{N}$ . Hence, there is  $n \in \mathbb{N}$  such that  $C - 1 < n$ . This, in turn, implies that  $C < n + 1$ , which is impossible.  $\square$

**Corollary 1.1.9.** Let  $\epsilon > 0$ . Then there is  $n \in \mathbb{N}$  such that  $0 < \frac{1}{n} < \epsilon$ .

*Proof.* By Theorem 1.1.8, there is  $n \in \mathbb{N}$  such that  $n > \epsilon^{-1}$ . This yields  $\frac{1}{n} < \epsilon$ .  $\square$

*Example.* Let

$$S := \left\{ 1 - \frac{1}{n} : n \in \mathbb{N} \right\} \subset \mathbb{R}$$

Then  $S$  is bounded below by 0 and above by 1. Since  $0 \in S$ , we have  $\inf S = 0$ .

Assume that  $\sup S < 1$ . Let  $\epsilon := 1 - \sup S$ . By Corollary 1.1.9, there is  $n \in \mathbb{N}$  with  $0 < \frac{1}{n} < \epsilon$ . But this, in turn, implies that

$$1 - \frac{1}{n} > 1 - \epsilon = \sup S,$$

which is a contradiction. Hence,  $\sup S = 1$  holds.

**Corollary 1.1.10.** Let  $x, y \in \mathbb{R}$  be such that  $x < y$ . Then there is  $q \in \mathbb{Q}$  such that  $x < q < y$ .

*Proof.* By Corollary 1.1.9, there is  $n \in \mathbb{N}$  such that  $\frac{1}{n} < y - x$ . Let  $m \in \mathbb{Z}$  be the smallest integer such that  $m > nx$ , so that  $m - 1 \leq nx$ . This implies

$$nx < m \leq nx + 1 < nx + n(y - x) = ny.$$

Division by  $n$  yields  $x < \frac{m}{n} < y$ .  $\square$

**Theorem 1.1.11.** Let  $x \in \mathbb{R}$  be such that  $x \geq 0$ . Then there is a unique  $y \geq 0$  such that  $y^2 = x$ . Moreover, if  $x \in \mathbb{N}$  and  $y \notin \mathbb{N}$ , then  $y \notin \mathbb{Q}$ .

*Proof.* To see that  $y$  is unique, suppose that there are  $y_1, y_2 \geq 0$  such that  $y_1^2 = y_2^2 = x$ . It follows that

$$0 = x - x = y_1^2 - y_2^2 = (y_1 - y_2)(y_1 + y_2),$$

so that  $y_1 - y_2 = 0$  or  $y_1 + y_2 = 0$ . If  $y_1 - y_2 = 0$ , then  $y_1 = y_2$ . If  $y_1 + y_2 = 0$ , then  $y_1 = 0 = y_2$ .

To prove the existence, set

$$S := \{z \in \mathbb{R} : z \geq 0 \text{ and } z^2 \leq x\}.$$

Then  $S$  is non-empty and bounded above, so that  $y := \sup S$  exists. Clearly,  $y \geq 0$  holds.

We claim that  $y^2 = x$ .

Assume that  $y^2 < x$ . Choose  $n \in \mathbb{N}$  such that  $\frac{1}{n} < \frac{x-y^2}{2y+1}$ . Then

$$\begin{aligned} \left(y + \frac{1}{n}\right)^2 &= y^2 + \frac{2y}{n} + \frac{1}{n^2} \\ &\leq y^2 + \frac{1}{n}(2y+1) \\ &< y^2 + x - y^2 \\ &= x \end{aligned}$$

holds, so that  $y$  cannot be an upper bound for  $S$ . Hence, we have a contradiction, so that  $y^2 \geq x$  must hold.

Assume now that  $y^2 > x$ . Choose  $n \in \mathbb{N}$  such that  $\frac{1}{n} < \frac{1}{2y}(y^2 - x)$ , and note that

$$\begin{aligned} \left(y - \frac{1}{n}\right)^2 &= y^2 - \frac{2y}{n} + \frac{1}{n^2} \\ &> y^2 - \frac{2y}{n} \\ &> y^2 - (y^2 - x) \\ &= x \\ &\geq z^2 \end{aligned}$$

for all  $z \in S$ . This, in turn, implies that  $y - \frac{1}{n} \geq z$  for all  $z \in S$ . Hence,  $y - \frac{1}{n} < y$  is an upper bound for  $S$ , which contradicts the definition of  $\sup S$ .

All in all,  $y^2 = x$  must hold.

Suppose now that  $x \in \mathbb{N}$ , and assume that  $y \in \mathbb{Q} \setminus \mathbb{N}$ . Let  $m, n \in \mathbb{N}$  be such that  $y = \frac{m}{n}$ , and suppose without loss of generality that  $\gcd(n, m) = 1$ . Let  $p_1, \dots, p_k$  and  $q_1, \dots, q_\ell$  be each pairwise distinct primes such that

$$m = p_1^{\mu_1} \cdots p_k^{\mu_k} \quad \text{and} \quad n = q_1^{\nu_1} \cdots q_\ell^{\nu_\ell}$$

for suitable  $\mu_1, \dots, \mu_k, \nu_1, \dots, \nu_\ell \in \mathbb{N}$ . As  $x = y^2 = \frac{m^2}{n^2}$ , it follows that

$$q_1^{2\nu_1} \cdots q_\ell^{2\nu_\ell} x = n^2 x = m^2 = p_1^{2\mu_1} \cdots p_k^{2\mu_k}.$$

Uniqueness of the prime factorization of  $n^2 x$  then yields  $\{q_1, \dots, q_\ell\} \subset \{p_1, \dots, p_k\}$ , which contradicts  $\gcd(m, n) = 1$ .  $\square$



The proof of this theorem shows that  $\mathbb{Q}$  is not complete: the set set

$$\{q \in \mathbb{Q} : q \geq 0 \text{ and } q^2 \leq 2\}$$

is bounded above, but has no supremum in  $\mathbb{Q}$ , for, if there were such a supremum, it would be a rational number  $q \geq 0$  with  $q^2 = 2$ . But the theorem asserts that no such rational number can exist.

For  $a, b \in \mathbb{R}$  with  $a < b$ , we introduce the following notation:

$$[a, b] := \{x \in \mathbb{R} : a \leq x \leq b\} \quad (\text{closed interval});$$

$$(a, b) := \{x \in \mathbb{R} : a < x < b\} \quad (\text{open interval});$$

$$(a, b] := \{x \in \mathbb{R} : a < x \leq b\};$$

$$[a, b) := \{x \in \mathbb{R} : a \leq x < b\}.$$

**Theorem 1.1.12** (Nested Interval Property). *Let  $I_1, I_2, I_3, \dots$  be a decreasing sequence of closed intervals, i.e.,  $I_n = [a_n, b_n]$  such that  $I_{n+1} \subset I_n$  for all  $n \in \mathbb{N}$ . Then  $\bigcap_{n=1}^{\infty} I_n \neq \emptyset$ .*

*Proof.* For all  $n \in \mathbb{N}$ , we have

$$a_1 \leq \dots \leq a_n \leq a_{n+1} \leq \dots < \dots \leq b_{n+1} \leq b_n \leq \dots \leq b_1.$$

Hence, each  $b_m$  is an upper bound for  $\{a_n : n \in \mathbb{N}\}$  for any  $m \in \mathbb{N}$ . Let  $x := \sup\{a_n : n \in \mathbb{N}\}$ . Hence,  $a_n \leq x \leq b_n$  holds for all  $n \in \mathbb{N}$ , i.e.,  $x \in I_n$  for all  $n \in \mathbb{N}$  and thus  $x \in \bigcap_{n=1}^{\infty} I_n$ .  $\square$

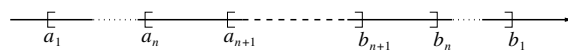

Figure 1.1: Nested Interval Property

The theorem becomes false if we no longer require the intervals to be closed:

*Example.* For  $n \in \mathbb{N}$ , let  $I_n := (0, \frac{1}{n}]$ , so that  $I_{n+1} \subset I_n$ . Assume that there is  $\epsilon \in \bigcap_{n=1}^{\infty} I_n$ , so that  $\epsilon > 0$ . By Corollary 1.1.9, there is  $n \in \mathbb{N}$  with  $0 < \frac{1}{n} < \epsilon$ , so that  $\epsilon \notin I_n$ . This is a contradiction.

**Definition 1.1.13.** For  $x \in \mathbb{R}$ , let

$$|x| := \begin{cases} x, & \text{if } x \geq 0, \\ -x, & \text{if } x \leq 0. \end{cases}$$

**Proposition 1.1.14.** *Let  $x, y \in \mathbb{R}$ , and let  $t \geq 0$ . Then the following hold:*

$$(i) \quad |x| = 0 \iff x = 0;$$

- (ii)  $|-x| = |x|$ ;
- (iii)  $|xy| = |x||y|$ ;
- (iv)  $|x| \leq t \iff -t \leq x \leq t$ ;
- (v)  $|x + y| \leq |x| + |y|$  (triangle inequality);
- (vi)  $||x| - |y|| \leq |x - y|$ .

*Proof.* (i), (ii), and (iii) are routinely checked.

(iv): Suppose that  $|x| \leq t$ . If  $x \geq 0$ , we have  $-t \leq x = |x| \leq t$ ; for  $x \leq 0$ , we have  $-x \geq 0$  and thus  $-t \leq -x \leq t$ . This implies  $-t \leq x \leq t$ . Hence,  $-t \leq x \leq t$  holds for any  $x$  with  $|x| \leq t$ .

Conversely, suppose that  $-t \leq x \leq t$ . For  $x \geq 0$ , this means  $x = |x| \leq t$ . For  $x \leq 0$ , the inequality  $-t \leq x$  implies that  $|x| = -x \leq t$ .

(v): By (iv), we have

$$-|x| \leq x \leq |x| \quad \text{and} \quad -|y| \leq y \leq |y|.$$

Adding these two inequalities yields

$$-(|x| + |y|) \leq x + y \leq |x| + |y|.$$

Again by (iv), we obtain  $|x + y| \leq |x| + |y|$  as claimed.

(vi): By (v), we have

$$|x| = |x - y + y| \leq |x - y| + |y|$$

and hence

$$|x| - |y| \leq |x - y|.$$

Exchanging the rôles of  $x$  and  $y$  yields

$$-(|x| - |y|) = |y| - |x| \leq |y - x| = |x - y|,$$

so that

$$||x| - |y|| \leq |x - y|$$

holds by (iv). □

**Exercises**

1. Let  $+$  and  $\cdot$  be defined on  $\{\spadesuit, \dagger, \circ, A\}$  through:

$+$	$\spadesuit$	$\dagger$	$\circ$	A
$\spadesuit$	$\spadesuit$	$\dagger$	$\circ$	A
$\dagger$	$\dagger$	$\circ$	A	$\spadesuit$
$\circ$	$\circ$	A	$\spadesuit$	$\dagger$
A	A	$\spadesuit$	$\dagger$	$\circ$

$\cdot$	$\spadesuit$	$\dagger$	$\circ$	A
$\spadesuit$	$\spadesuit$	$\spadesuit$	$\spadesuit$	$\spadesuit$
$\dagger$	$\spadesuit$	$\dagger$	$\circ$	A
$\circ$	$\spadesuit$	$\circ$	$\spadesuit$	$\circ$
A	$\spadesuit$	A	$\circ$	$\dagger$

Do these turn  $\{\spadesuit, \dagger, \circ, A\}$  into a field?

2. Show that

$$\mathbb{Q}[\sqrt{2}] := \left\{ p + q\sqrt{2} : p, q \in \mathbb{Q} \right\},$$

with  $+$  and  $\cdot$  inherited from  $\mathbb{R}$ , is a field. (*Hint:* Many of the field axioms are true for  $\mathbb{Q}[\sqrt{2}]$  simply because they are true for  $\mathbb{R}$ ; in this case, just point it out and don't verify the axiom in detail.)

3. Let

$$\mathbb{F} := \left\{ \begin{bmatrix} a & -b \\ b & a \end{bmatrix} : a, b \in \mathbb{R} \right\}$$

be equipped with addition and multiplication of matrices. Show that  $\mathbb{F}$  is a field. (*Hint:* Many properties of a field follow immediately from corresponding properties of addition and multiplication of matrices.)

4. Let  $\mathbb{O}$  be an ordered field, and let  $x, y, z, u \in \mathbb{O}$ :

- (a) suppose that  $x < y$  and  $z < u$ , and show that  $x + z < y + u$ ;  
 (b) suppose that  $0 \leq x < y$  and  $0 \leq z < u$ , and show that  $xz < yu$ .

You may use the axioms of an ordered field and all the properties that were derived from them in class.

5. Let  $\emptyset \neq S \subset \mathbb{R}$  be bounded below, and let  $-S := \{-x : x \in S\}$ . Show that:

- (a)  $-S$  is bounded above.  
 (b)  $S$  has an infimum, namely  $\inf S = -\sup(-S)$ .

6. Find  $\sup S$  and  $\inf S$  in  $\mathbb{R}$  for

$$S := \left\{ (-1)^n \left( 1 - \frac{1}{n} \right) : n \in \mathbb{N} \right\}.$$

Justify, i.e., *prove*, your findings.

7. Let  $S, T \subset \mathbb{R}$  be non-empty and bounded above. Show that

$$S + T := \{x + y : x \in S, y \in T\}$$

is also bounded above with

$$\sup(S + T) = \sup S + \sup T.$$

8. An ordered field  $\mathbb{O}$  is said to have the *nested interval property* if  $\bigcap_{n=1}^{\infty} I_n \neq \emptyset$  for each decreasing sequence  $I_1 \supset I_2 \supset I_3 \supset \cdots$  of closed intervals in  $\mathbb{O}$ .

Show that an Archimedean ordered field with the nested interval property is complete.

9. Let  $x, y \in \mathbb{R}$  with  $x < y$ . Show that there is  $z \in \mathbb{R} \setminus \mathbb{Q}$  such that  $x < z < y$ .

## 1.2 Functions

In this section, we give a somewhat formal introduction to functions and introduce the notions of injectivity, surjectivity, and bijectivity. We use bijective maps to define what it means for two (possibly infinite) sets to be “of the same size” and show that  $\mathbb{N}$  and  $\mathbb{Q}$  have “the same size” whereas  $\mathbb{R}$  is “larger” than  $\mathbb{Q}$ .

**Definition 1.2.1.** Let  $A$  and  $B$  be non-empty sets. A subset  $f$  of

$$A \times B := \{(a, b) : a \in A, b \in B\}$$

is called a *function, mapping map* if, for each  $x \in A$ , there is a unique  $y \in B$  such that  $(x, y) \in f$ .

For a function  $f \subset A \times B$ , we write  $f: A \rightarrow B$  and, for  $(x, y) \in A \times B$ ,

$$y = f(x) \quad :\iff \quad (x, y) \in f.$$

We then often write

$$f: A \rightarrow B, \quad x \mapsto f(x).$$

The set  $A$  is called the *domain* of  $f$ , and  $B$  is called its *co-domain*.

**Definition 1.2.2.** Let  $A$  and  $B$  be non-empty sets, let  $f: A \rightarrow B$  be a function, and let  $X \subset A$  and  $Y \subset B$ . Then

$$f(X) := \{f(x) : x \in X\} \subset B$$

is the *image of  $X$*  (under  $f$ ), and

$$f^{-1}(Y) := \{x \in A : f(x) \in Y\} \subset A$$

is the *inverse image of  $Y$*  (under  $f$ ). The set  $f(A)$  is called the *range of  $f$* .

*Example.* Consider  $\sin: \mathbb{R} \rightarrow \mathbb{R}$ , i.e.,  $\{(x, \sin(x)) : x \in \mathbb{R}\} \subset \mathbb{R} \times \mathbb{R}$ . Then we have:

$$\begin{aligned}\sin(\mathbb{R}) &= [-1, 1]; \\ \sin([0, \pi]) &= [0, 1]; \\ \sin^{-1}(\{0\}) &= \{n\pi : n \in \mathbb{Z}\}; \\ \sin^{-1}(\{x \in \mathbb{R} : x \geq 7\}) &= \emptyset.\end{aligned}$$

**Definition 1.2.3.** Let  $A$  and  $B$  be non-empty sets, and let  $f: A \rightarrow B$  be a function. Then  $f$  is called:

- (a) *injective* if  $f(x_1) \neq f(x_2)$  whenever  $x_1 \neq x_2$  for  $x_1, x_2 \in A$ ;
- (b) *surjective* if  $f(A) = B$ ;
- (c) *bijective* if it is both injective and surjective.

*Examples.*

1. The function

$$f_1: \mathbb{R} \rightarrow \mathbb{R}, \quad x \mapsto x^2$$

is neither injective nor surjective, whereas

$$\begin{aligned}f_2: \underbrace{[0, \infty)}_{:=\{x \in \mathbb{R} : x \geq 0\}} &\rightarrow \mathbb{R}, \quad x \mapsto x^2\end{aligned}$$

is injective, but not surjective, and

$$f_3: [0, \infty) \rightarrow [0, \infty), \quad x \mapsto x^2$$

is bijective.

2. The function

$$\sin: [0, 2\pi] \rightarrow [-1, 1], \quad x \mapsto \sin(x)$$

is surjective, but not injective.

*Remark.* If  $f: A \rightarrow B$  is bijective, the map

$$B \rightarrow A, \quad f(x) \rightarrow x$$

is well defined and called the *inverse map* and denoted by  $f^{-1}: A \rightarrow B$ .

For finite sets, it is obvious what it means for two sets to have the same size or for one of them to be smaller or larger than the other one. For infinite sets, matters are more complicated:

*Example.* Let  $\mathbb{N}_0 := \mathbb{N} \cup \{0\}$ . Then  $\mathbb{N}$  is a proper subset of  $\mathbb{N}_0$ , so that  $\mathbb{N}$  should be “smaller” than  $\mathbb{N}_0$ . On the other hand,

$$\mathbb{N}_0 \rightarrow \mathbb{N}, \quad n \mapsto n + 1$$

is bijective, i.e., there is a one-to-one correspondence between the elements of  $\mathbb{N}_0$  and  $\mathbb{N}$ . Hence,  $\mathbb{N}_0$  and  $\mathbb{N}$  should “have the same size”.

We use the second idea from the previous example to define what it means for two sets to have “the same size”:

**Definition 1.2.4.** Two sets  $A$  and  $B$  are said to have the same *cardinality*—in symbols:  $|A| = |B|$ —if there is a bijective map  $f: A \rightarrow B$ .

*Examples.*

1. If  $A$  and  $B$  are finite, then  $|A| = |B|$  holds if and only if  $A$  and  $B$  have the same number of elements.
2. By the previous example, we have  $|\mathbb{N}| = |\mathbb{N}_0|$ —even though  $\mathbb{N}$  is a proper subset of  $\mathbb{N}_0$ .
3. The function

$$f: \mathbb{N} \rightarrow \mathbb{Z}, \quad n \mapsto (-1)^n \left\lfloor \frac{n}{2} \right\rfloor$$

is bijective, so that we can enumerate  $\mathbb{Z}$  as  $\{0, 1, -1, 2, -2, \dots\}$ . As a consequence,  $|\mathbb{N}| = |\mathbb{Z}|$  holds even though  $\mathbb{N} \subsetneq \mathbb{Z}$ .

4. Let  $a_1, a_2, a_3, \dots$  be an enumeration of  $\mathbb{Z}$ . We can then write  $\mathbb{Q}$  as a rectangular scheme that allows us to enumerate  $\mathbb{Q}$ . Omitting duplicates, we conclude that  $|\mathbb{Q}| = |\mathbb{N}|$ :

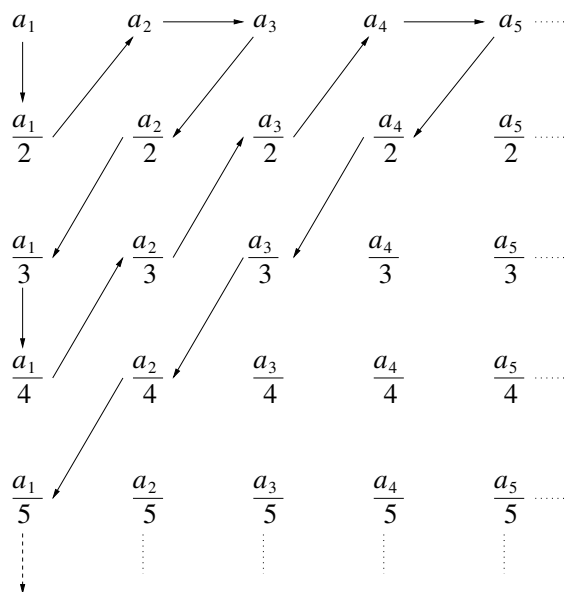

Figure 1.2: Enumeration of  $\mathbb{Q}$

5. Let  $a < b$ . The function

$$f: [a, b] \rightarrow [0, 1], \quad x \mapsto \frac{x - a}{b - a}$$

is bijective, so that  $|[a, b]| = |[0, 1]|$ .

**Definition 1.2.5.** A set  $A$  is called *countable* if it is finite or if  $|A| = |\mathbb{N}|$ .

A set  $A$  is countable, if and only if we can enumerate it, i.e.,  $A = \{a_1, a_2, a_3, \dots\}$  where the sequence  $a_1, a_2, a_3, \dots$  may break off after a finite number of terms.

As we have already seen, the sets  $\mathbb{N}$ ,  $\mathbb{N}_0$ ,  $\mathbb{Z}$ , and  $\mathbb{Q}$  are all countable. But not all sets are:

**Theorem 1.2.6.** *The sets  $[0, 1]$  and  $\mathbb{R}$  are not countable.*

*Proof.* We only consider  $[0, 1]$  (this is enough because it is easy to see that a infinite subsets of a countable set must again be countable).

Each  $x \in [0, 1]$  has a decimal expansion

$$x = 0.\epsilon_1\epsilon_2\epsilon_3 \cdots \tag{1.1}$$

with  $\epsilon_1, \epsilon_2, \epsilon_3, \dots \in \{0, 1, 2, \dots, 9\}$ .

Assume that there is an enumeration  $[0, 1] = \{a_1, a_2, a_3, \dots\}$ . Define  $x \in [0, 1]$  using (1.1) by letting, for  $n \in \mathbb{N}$ ,

$$\epsilon_n := \begin{cases} 6, & \text{if the } n\text{-th digit of } a_n \text{ is } 7, \\ 7, & \text{if the } n\text{-th digit of } a_n \text{ is not } 7 \end{cases}$$

Let  $n \in \mathbb{N}$  be such that  $x = a_n$ .

*Case 1:* The  $n$ -th digit of  $a_n$  is 7. Then the  $n$ -th digit of  $x$  is 6, so that  $a_n \neq x$ .

*Case 2:* The  $n$ -th digit of  $a_n$  is not 7. Then the  $n$ -th digit of  $x$  is 7, so that  $a_n \neq x$ , too.

Hence,  $x \notin \{a_1, a_2, a_3, \dots\}$ , which contradicts  $[0, 1] = \{a_1, a_2, a_3, \dots\}$ .  $\square$

The argument used in the proof of Theorem 1.2.6 is called *Cantor's Diagonal Argument*.

### Exercises

1. Let  $\tilde{\mathbb{R}}$  be a complete ordered field, and let  $\iota_0: \mathbb{Q} \rightarrow \tilde{\mathbb{R}}$  be the canonical embedding. Show that

$$\iota: \mathbb{R} \rightarrow \tilde{\mathbb{R}}, \quad x \mapsto \sup\{\iota_0(q) : q \in \mathbb{Q}, q \leq x\}$$

defines a bijective map satisfying:

- $\iota(x + y) = \iota(x) + \iota(y)$  for  $x, y \in \mathbb{R}$ ;
  - $\iota(xy) = \iota(x)\iota(y)$  for  $x, y \in \mathbb{R}$ ;
  - $\iota(x) > 0$  if  $x > 0$ .
2. For any set  $S$ , its *power set*  $\mathfrak{P}(S)$  is defined to be the set consisting of all subsets of  $S$ . Show that there is *no* surjective map from  $S$  to  $\mathfrak{P}(S)$ . (*Hint:* Assume that there is a surjective map  $f: S \rightarrow \mathfrak{P}(S)$  and consider the set  $\{x \in S : x \notin f(x)\}$ .)

## 1.3 The Euclidean Space $\mathbb{R}^N$

Recall that, for any sets  $S_1, \dots, S_N$ , their ( $N$ -fold) *Cartesian product* is defined as

$$S_1 \times \cdots \times S_N := \{(s_1, \dots, s_N) : s_j \in S_j \text{ for } j = 1, \dots, N\}.$$

The  $N$ -dimensional *Euclidean space* is defined as

$$\mathbb{R}^N := \underbrace{\mathbb{R} \times \cdots \times \mathbb{R}}_{N \text{ times}} = \{(x_1, \dots, x_N) : x_1, \dots, x_N \in \mathbb{R}\}.$$

An element  $x := (x_1, \dots, x_N) \in \mathbb{R}^N$  is called a *point* or *vector* in  $\mathbb{R}^N$ ; the real numbers  $x_1, \dots, x_N \in \mathbb{R}$  are the *coordinates* of  $x$ . The vector  $0 := (0, \dots, 0)$  is the *origin* or *zero vector* of  $\mathbb{R}^N$ . (For  $N = 2$  and  $N = 3$ , the space  $\mathbb{R}^N$  can be identified with the plane and three-dimensional space of geometric intuition.)



We can add vectors in  $\mathbb{R}^N$  and multiply them with real numbers: For two vectors  $x = (x_1, \dots, x_N), y := (y_1, \dots, y_N) \in \mathbb{R}^N$  and a *scalar*  $\lambda \in \mathbb{R}$  define:

$$\begin{aligned}x + y &:= (x_1 + y_1, \dots, x_N + y_N) && \text{(addition);} \\ \lambda x &:= (\lambda x_1, \dots, \lambda x_N) && \text{(scalar multiplication).}\end{aligned}$$

The following rules for addition and scalar multiplication in  $\mathbb{R}^N$  are easily verified:

$$\begin{aligned}x + y &= y + x; \\ (x + y) + z &= x + (y + z); \\ 0 + x &= x; \\ x + (-1)x &= 0; \\ 1x &= x; \\ 0x &= 0; \\ \lambda(\mu x) &= (\lambda\mu)x; \\ \lambda(x + y) &= \lambda x + \lambda y; \\ (\lambda + \mu)x &= \lambda x + \mu x.\end{aligned}$$

This means that  $\mathbb{R}^N$  is a *vector space*.

**Definition 1.3.1.** The *dot product* on  $\mathbb{R}^N$  is defined by

$$x \cdot y := \sum_{j=1}^N x_j y_j$$

for  $x = (x_1, \dots, x_N), y := (y_1, \dots, y_N) \in \mathbb{R}^N$ .

**Proposition 1.3.2.** *The following hold for all  $x, y, z \in \mathbb{R}^N$  and  $\lambda \in \mathbb{R}$ :*

- (i)  $x \cdot x \geq 0$ ;
- (ii)  $x \cdot x = 0 \iff x = 0$ ;
- (iii)  $x \cdot y = y \cdot x$ ;
- (iv)  $x \cdot (y + z) = x \cdot y + x \cdot z$ ;
- (v)  $(\lambda x) \cdot y = \lambda(x \cdot y) = x \cdot \lambda y$ .

**Definition 1.3.3.** The (*Euclidean*) *norm* on  $\mathbb{R}^N$  is defined by

$$\|x\| := \sqrt{x \cdot x} = \sqrt{\sum_{j=1}^N x_j^2}$$

for  $x = (x_1, \dots, x_N)$ .

For  $N = 2, 3$ , the norm  $\|x\|$  of a vector  $x \in \mathbb{R}^N$  can be interpreted as its length. The Euclidean norm on  $\mathbb{R}^N$  thus extends the notion of length in 2- and 3-dimensional space, respectively, to arbitrary dimensions.

**Lemma 1.3.4** (Geometric versus Arithmetic Mean). *For  $x, y \geq 0$ , the inequality*

$$\sqrt{xy} \leq \frac{1}{2}(x + y)$$

*holds with equality if and only if  $x = y$ .*

*Proof.* We have

$$x^2 - 2xy + y^2 = (x - y)^2 \geq 0 \tag{1.2}$$

with equality if and only if  $x = y$ . This yields

$$\begin{aligned} xy &\leq xy + \frac{1}{4}(x^2 - 2xy + y^2) \\ &= xy + \frac{1}{4}x^2 - \frac{1}{2}xy + \frac{1}{4}y^2 \\ &= \frac{1}{4}x^2 + \frac{1}{2}xy + \frac{1}{4}y^2 \\ &= \frac{1}{4}(x^2 + 2xy + y^2) \\ &= \frac{1}{4}(x + y)^2. \end{aligned} \tag{1.3}$$

Taking roots yields the desired inequality. It is clear that we have equality if and only if the second summand in (1.3) vanishes; by (1.2) this is possible only if  $x = y$ .  $\square$

**Theorem 1.3.5** (Cauchy–Schwarz Inequality). *We have*

$$|x \cdot y| \leq \sum_{j=1}^N |x_j y_j| \leq \|x\| \|y\|$$

for  $x = (x_1, \dots, x_N), y := (y_1, \dots, y_N) \in \mathbb{R}^N$ .

*Proof.* The first inequality is clear due to the triangle inequality in  $\mathbb{R}$ .

If  $\|x\| = 0$ , then  $x_1 = \dots = x_N = 0$ , so that  $\sum_{j=1}^N |x_j y_j| = 0$ ; a similar argument

applies if  $\|y\| = 0$ . We may therefore suppose that  $\|x\|\|y\| \neq 0$ . We then obtain

$$\begin{aligned} \sum_{j=1}^N \frac{|x_j| |y_j|}{\|x\| \|y\|} &= \sum_{j=1}^N \sqrt{\left(\frac{x_j}{\|x\|}\right)^2 \left(\frac{y_j}{\|y\|}\right)^2} \\ &\leq \sum_{j=1}^N \frac{1}{2} \left[ \left(\frac{x_j}{\|x\|}\right)^2 + \left(\frac{y_j}{\|y\|}\right)^2 \right], && \text{by Lemma 1.3.4,} \\ &= \frac{1}{2} \left[ \frac{1}{\|x\|^2} \sum_{j=1}^N x_j^2 + \frac{1}{\|y\|^2} \sum_{j=1}^N y_j^2 \right] \\ &= \frac{1}{2} \left[ \frac{\|x\|^2}{\|x\|^2} + \frac{\|y\|^2}{\|y\|^2} \right] \\ &= 1. \end{aligned}$$

Multiplication by  $\|x\|\|y\|$  yields the claim. □

**Proposition 1.3.6** (Properties of  $\|\cdot\|$ ). *For  $x, y \in \mathbb{R}^N$  and  $\lambda \in \mathbb{R}$ , we have:*

- (i)  $\|x\| \geq 0$ ;
- (ii)  $\|x\| = 0 \iff x = 0$ ;
- (iii)  $\|\lambda x\| = |\lambda| \|x\|$ ;
- (iv)  $\|x + y\| \leq \|x\| + \|y\|$  (triangle inequality);
- (v)  $|\|x\| - \|y\|| \leq \|x - y\|$ .

*Proof.* (i), (ii), and (iii) are easily verified.

For (iv), note that

$$\begin{aligned} \|x + y\|^2 &= (x + y) \cdot (x + y) \\ &= x \cdot x + x \cdot y + y \cdot x + y \cdot y \\ &= \|x\|^2 + 2x \cdot y + \|y\|^2 \\ &\leq \|x\|^2 + 2\|x\|\|y\| + \|y\|^2, && \text{by Theorem 1.3.5,} \\ &= (\|x\| + \|y\|)^2. \end{aligned}$$

Taking roots yields the claim.

For (v), note that—by (iv) with  $x$  and  $y$  replaced by  $x - y$  and  $y$ —

$$\|x\| = \|(x - y) + y\| \leq \|x - y\| + \|y\|,$$

holds, so that

$$\|x\| - \|y\| \leq \|x - y\|.$$

Interchanging  $x$  and  $y$  yields

$$\|y\| - \|x\| \leq \|y - x\| = \|x - y\|,$$

so that

$$-\|x - y\| \leq \|x\| - \|y\| \leq \|x - y\|.$$

This proves (v). □

We now use the norm on  $\mathbb{R}^N$  to define two important types of subsets of  $\mathbb{R}^N$ :

**Definition 1.3.7.** Let  $x_0 \in \mathbb{R}^N$  and let  $r > 0$ . Then:

(a) the *open ball* in  $\mathbb{R}^N$  centered at  $x_0$  with radius  $r$  is the set

$$B_r(x_0) := \{x \in \mathbb{R}^N : \|x - x_0\| < r\}.$$

(b) the *closed ball* in  $\mathbb{R}^N$  centered at  $x_0$  with radius  $r$  is the set

$$B_r[x_0] := \{x \in \mathbb{R}^N : \|x - x_0\| \leq r\}.$$

For  $N = 1$ ,  $B_r(x_0)$  and  $B_r[x_0]$  are nothing but open and closed intervals, respectively, namely

$$B_r(x_0) = (x_0 - r, x_0 + r) \quad \text{and} \quad B_r[x_0] = [x_0 - r, x_0 + r].$$

Moreover, if  $a < b$ , then

$$(a, b) = (x_0 - r, x_0 + r) \quad \text{and} \quad [a, b] = [x_0 - r, x_0 + r]$$

holds, with  $x_0 := \frac{1}{2}(a + b)$  and  $r := \frac{1}{2}(b - a)$ .

For  $N = 2$ ,  $B_r(x_0)$  and  $B_r[x_0]$  are just disks with center  $x_0$  and radius  $r$ , where the circle is not included in the case of  $B_r(x_0)$ , but is included for  $B_r[x_0]$ .

Finally, if  $N = 3$ , then  $B_r(x_0)$  and  $B_r[x_0]$  are balls in the sense of geometric intuition. In the open case, the surface of the ball is not included, but it is included in the closed ball.

**Definition 1.3.8.** A set  $C \subset \mathbb{R}^N$  is called *convex* if  $tx + (1 - t)y \in C$  for all  $x, y \in C$  and  $t \in [0, 1]$ .

In plain language, a set is convex if, for any two points  $x$  and  $y$  in the  $C$ , the whole line segment joining  $x$  and  $y$  is also in  $C$ :

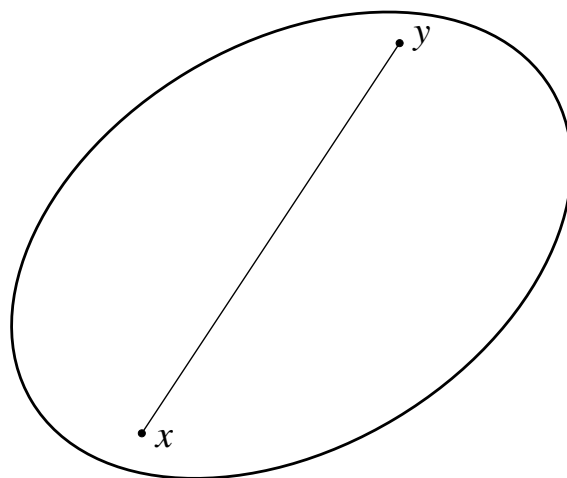
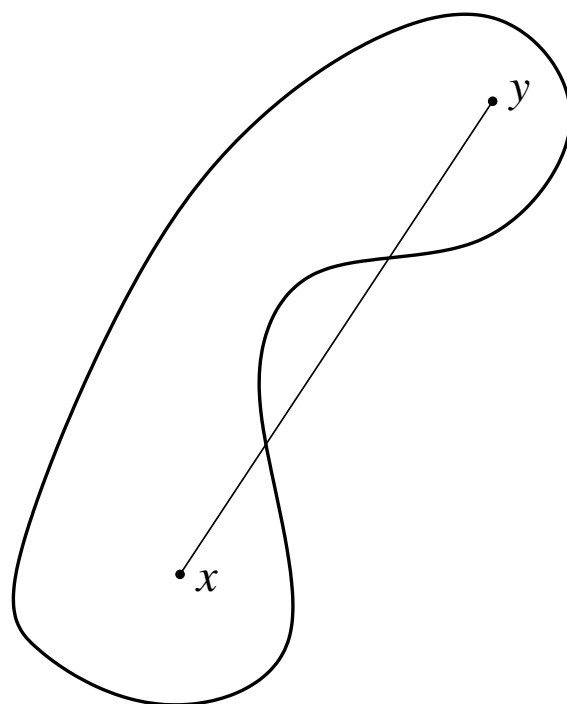
Figure 1.3: A convex subset of  $\mathbb{R}^2$ Figure 1.4: Not a convex subset of  $\mathbb{R}^2$ 

**Proposition 1.3.9.** *Let  $x_0 \in \mathbb{R}^N$ , and let  $r > 0$ . Then  $B_r(x_0)$  and  $B_r[x_0]$  are convex.*

*Proof.* We only prove the claim for  $B_r(x_0)$  in detail.

Let  $x, y \in B_r(x_0)$  and  $t \in [0, 1]$ . Then we have

$$\begin{aligned} \|tx + (1-t)y - x_0\| &= \|t(x - x_0) + (1-t)(y - x_0)\| \\ &\leq t\|x - x_0\| + (1-t)\|y - x_0\| \\ &< tr + (1-t)r \\ &= r, \end{aligned} \tag{1.4}$$

so that  $tx + (1-t)y \in B_r(x_0)$ .

The claim for  $B_r[x_0]$  is proved similarly, but with  $\leq$  instead of  $<$  in (1.4).  $\square$

Let  $I_1, \dots, I_N \subset \mathbb{R}$  be closed intervals, i.e.,  $I_j = [a_j, b_j]$  where  $a_j < b_j$  for  $j = 1, \dots, N$ . Then  $I := I_1 \times \dots \times I_N$  is called a *closed interval* in  $\mathbb{R}^N$ . We have

$$I = \{(x_1, \dots, x_N) \in \mathbb{R}^N : a_j \leq x_j \leq b_j \text{ for } j = 1, \dots, N\}.$$

For  $N = 2$ , a closed interval in  $\mathbb{R}^N$ , i.e., in the plane, is just a rectangle. For  $N = 3$ , a closed interval in  $\mathbb{R}^3$  is a rectangular box.

**Theorem 1.3.10** (Nested Interval Property in  $\mathbb{R}^N$ ). *Let  $I_1, I_2, I_3, \dots$  be a decreasing sequence of closed intervals in  $\mathbb{R}^N$ . Then  $\bigcap_{n=1}^{\infty} I_n \neq \emptyset$  holds.*

*Proof.* Each interval  $I_n$  is of the form

$$I_n = I_{n,1} \times \dots \times I_{n,N}$$

with closed intervals  $I_{n,1}, \dots, I_{n,N}$  in  $\mathbb{R}$ . For each  $j = 1, \dots, N$ , we have

$$I_{1,j} \supset I_{2,j} \supset I_{3,j} \supset \dots,$$

i.e., the sequence  $I_{1,j}, I_{2,j}, I_{3,j}, \dots$  is a decreasing sequence of closed intervals in  $\mathbb{R}$ . By Theorem 1.1.12, this means that  $\bigcap_{n=1}^{\infty} I_{n,j} \neq \emptyset$ , i.e., there is  $x_j \in I_{n,j}$  for all  $n \in \mathbb{N}$ . Let  $x := (x_1, \dots, x_N)$ . Then  $x \in I_{n,1} \times \dots \times I_{n,N}$  holds for all  $n \in \mathbb{N}$ , which means that  $x \in \bigcap_{n=1}^{\infty} I_n$ .  $\square$

### Exercises

1. For  $x = (x_1, \dots, x_N) \in \mathbb{R}^N$ , set

$$\|x\|_1 := |x_1| + \dots + |x_N| \quad \text{and} \quad \|x\|_{\infty} := \max\{|x_1|, \dots, |x_N|\}.$$

(a) Show that the following are true for  $j = 1, \infty$ ,  $x, y \in \mathbb{R}^N$  and  $\lambda \in \mathbb{R}$ :

- (i)  $\|x\|_j \geq 0$  and  $\|x\|_j = 0$  if and only if  $x = 0$ ;
- (ii)  $\|\lambda x\|_j = |\lambda| \|x\|_j$ ;

$$(iii) \|x + y\|_j \leq \|x\|_j + \|y\|_j.$$

(b) For  $N = 2$ , sketch the sets of those  $x$  for which  $\|x\|_1 \leq 1$ ,  $\|x\| \leq 1$ , and  $\|x\|_\infty \leq 1$ .

(c) Show that

$$\|x\|_1 \leq \sqrt{N}\|x\| \leq N\|x\|_\infty$$

for all  $x \in \mathbb{R}^N$ .

2. Let  $x, y \in \mathbb{R}^N$ . Show that  $|x \cdot y| = \|x\|\|y\|$  holds if and only if  $x$  and  $y$  are linearly dependent.

3. Show that

$$\|x + y\|^2 = \|x\|^2 + \|y\|^2 \iff x \cdot y = 0$$

for any  $x, y \in \mathbb{R}^N$ .

4. Let  $\mathcal{C}$  be a family of convex sets in  $\mathbb{R}^N$ . Show that  $\bigcap_{C \in \mathcal{C}} C$  is again convex. Is  $\bigcup_{C \in \mathcal{C}} C$  necessarily convex?

## 1.4 Topology

The word topology derives from the Greek and literally means “study of places”. In mathematics, topology is the discipline that provides the conceptual framework for the study of continuous functions.

**Definition 1.4.1.** Let  $x_0 \in \mathbb{R}^N$ . A set  $U \subset \mathbb{R}^N$  is called a *neighborhood* of  $x_0$  if there is  $\epsilon > 0$  such that  $B_\epsilon(x_0) \subset U$ .

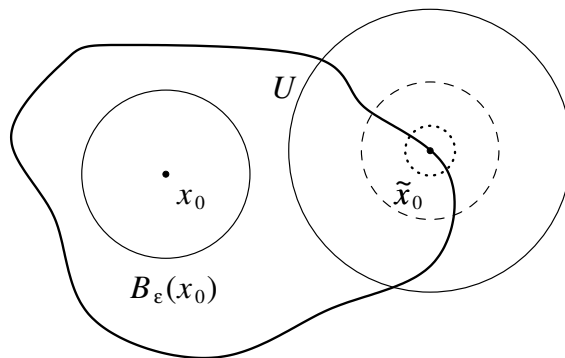

Figure 1.5: A neighborhood of  $x_0$ , but not of  $\tilde{x}_0$

*Examples.*

1. If  $x_0 \in \mathbb{R}^N$  is arbitrary, and  $r > 0$ , then both  $B_r(x_0)$  and  $B_r[x_0]$  are neighborhoods of  $x_0$ .
2. The interval  $[a, b]$  is not a neighborhood of  $a$ : To see this assume that it is a neighborhood of  $a$ . Then there is  $\epsilon > 0$  such that

$$B_\epsilon(a) = (a - \epsilon, a + \epsilon) \subset [a, b],$$

which would mean that  $a - \epsilon \geq a$ . This is a contradiction.

Similarly,  $[a, b]$  is not a neighborhood of  $b$ ,  $[a, b)$  is not a neighborhood of  $a$ , and  $(a, b]$  is not a neighborhood of  $b$ .

**Definition 1.4.2.** A set  $U \subset \mathbb{R}^N$  is *open* if it is a neighborhood of each of its points.

*Examples.*

1.  $\emptyset$  and  $\mathbb{R}^N$  are trivially open.
2. Let  $x_0 \in \mathbb{R}^N$ , and let  $r > 0$ . We claim that  $B_r(x_0)$  is open. Let  $x \in B_r(x_0)$ . Choose  $\epsilon \leq r - \|x - x_0\|$ , and let  $y \in B_\epsilon(x)$ . It follows that

$$\begin{aligned} \|y - x_0\| &\leq \underbrace{\|y - x\|}_{< \epsilon} + \|x - x_0\| \\ &< r - \|x - x_0\| + \|x - x_0\| \\ &= r; \end{aligned}$$

hence,  $B_\epsilon(x) \subset B_r(x_0)$  holds.

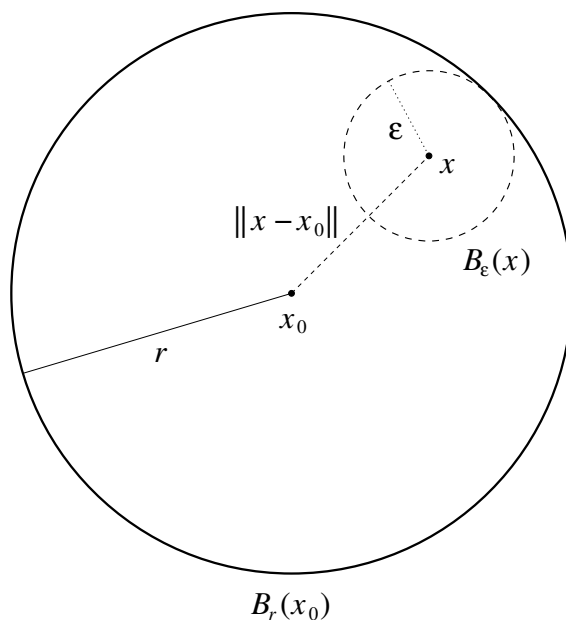

Figure 1.6: Open balls are open



In particular,  $(a, b)$  is open for all  $a, b \in \mathbb{R}$  such that  $a < b$ . On the other hand,  $[a, b]$ ,  $(a, b]$ , and  $[a, b)$  are not open.

3. The set

$$S := \{(x, y, z) \in \mathbb{R}^3 : y^2 + z^2 = 1, x > 0\}$$

is not open.

*Proof.* Clearly,  $x_0 := (1, 0, 1) \in S$ . Assume that there is  $\epsilon > 0$  such that  $B_\epsilon(x_0) \subset S$ . It follows that

$$\left(1, 0, 1 + \frac{\epsilon}{2}\right) \in B_\epsilon(x_0) \subset S.$$

On the other hand, however, we have

$$\left(1 + \frac{\epsilon}{2}\right)^2 > 1,$$

so that  $(1, 0, 1 + \frac{\epsilon}{2})$  cannot belong to  $S$ .  $\square$

To determine whether or not a given set is open is often difficult if one has nothing more but the definition at one's disposal. The following two hereditary properties are often useful:

**Proposition 1.4.3.** *The following are true:*

- (i) if  $U, V \subset \mathbb{R}^N$  are open, then  $U \cap V$  is open;
- (ii) if  $\mathbb{I}$  is any index set and  $\{U_i : i \in \mathbb{I}\}$  is a collection of open sets, then  $\bigcup_{i \in \mathbb{I}} U_i$  is open.

*Proof.* (i): Let  $x_0 \in U \cap V$ . Since  $U$  is open, there is  $\epsilon_1 > 0$  such that  $B_{\epsilon_1}(x_0) \subset U$ , and since  $V$  is open, there is  $\epsilon_2 > 0$  such that  $B_{\epsilon_2}(x_0) \subset V$ . Let  $\epsilon := \min\{\epsilon_1, \epsilon_2\}$ . Then

$$B_\epsilon(x_0) \subset B_{\epsilon_1}(x_0) \cap B_{\epsilon_2}(x_0) \subset U \cap V$$

holds, so that  $U \cap V$  is open.

(ii): Let  $x_0 \in U := \bigcup_{i \in \mathbb{I}} U_i$ . Then there is  $i_0 \in \mathbb{I}$  such that  $x_0 \in U_{i_0}$ . Since  $U_{i_0}$  is open, there is  $\epsilon > 0$  such that  $B_\epsilon(x_0) \subset U_{i_0} \subset U$ . Hence,  $U$  is open.  $\square$

*Example.* The subset  $\bigcup_{n=1}^{\infty} B_{\frac{n}{2}}((n, 0))$  of  $\mathbb{R}^2$  is open because it is the union of a sequence of open sets.

**Definition 1.4.4.** A set  $F \subset \mathbb{R}^N$  is called *closed* if

$$F^c := \mathbb{R}^N \setminus F := \{x \in \mathbb{R}^N : x \notin F\}$$

is open.

*Examples.*

1.  $\emptyset$  and  $\mathbb{R}^N$  are (trivially) closed.
2. Let  $x_0 \in \mathbb{R}^N$ , and let  $r > 0$ . We claim that  $B_r[x_0]$  is closed. To see this, let  $x \in B_r[x_0]^c$ , i.e.,  $\|x - x_0\| > r$ . Choose  $\epsilon \leq \|x - x_0\| - r$ , and let  $y \in B_\epsilon(x)$ . Then we have

$$\begin{aligned} \|y - x_0\| &\geq \| \|y - x\| - \|x - x_0\| \| \\ &\geq \|x - x_0\| - \|y - x\| \\ &> \|x - x_0\| - \|x - x_0\| + r \\ &= r, \end{aligned}$$

so that  $B_\epsilon(x) \subset B_r[x_0]^c$ . It follows that  $B_r[x_0]^c$  is open, i.e.,  $B_r[x_0]$  is closed.

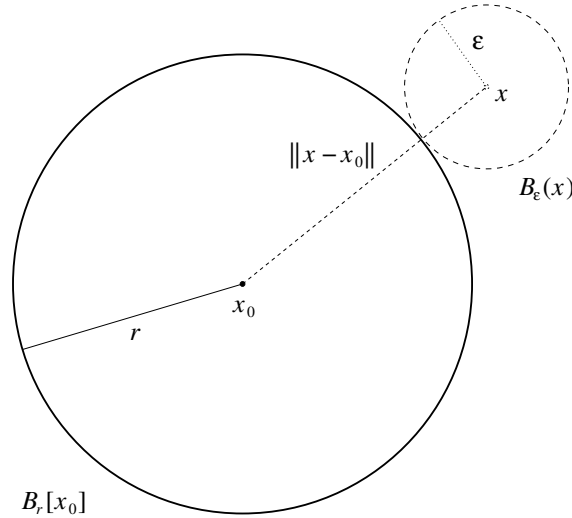

Figure 1.7: Closed balls are closed

In particular,  $[a, b]$  is closed for all  $a, b \in \mathbb{R}$  with  $a < b$ .

3. For  $a, b \in \mathbb{R}$  with  $a < b$ , the interval  $(a, b]$  is not open because  $(b - \epsilon, b + \epsilon) \not\subset (a, b]$  for all  $\epsilon > 0$ . But  $(a, b]$  is not open either because  $(a - \epsilon, a + \epsilon) \not\subset \mathbb{R} \setminus (a, b]$ .

**Proposition 1.4.5.** *The following are true:*

- (i) if  $F, G \subset \mathbb{R}^N$  are closed, then  $F \cup G$  is closed;
- (ii) if  $\mathbb{I}$  is any index set and  $\{F_i : i \in \mathbb{I}\}$  is a collection of closed sets, then  $\bigcap_{i \in \mathbb{I}} F_i$  is closed.

*Proof.* (i): Since  $F^c$  and  $G^c$  are open, so is  $F^c \cap G^c = (F \cup G)^c$  by Proposition 1.4.3(i). Hence,  $F \cup G$  is closed.

(ii): Since  $F_i^c$  is open for each  $i \in \mathbb{I}$ , Proposition 1.4.3(ii) yields the openness of

$$\bigcup_{i \in \mathbb{I}} F_i^c = \left( \bigcap_{i \in \mathbb{I}} F_i \right)^c,$$

which, in turn, means that  $\bigcap_{i \in \mathbb{I}} F_i$  is closed.  $\square$

*Example.* Let  $x \in \mathbb{R}^N$ . Since  $\{x\} = \bigcap_{r>0} B_r[x]$ , it follows that  $\{x\}$  is closed. Consequently, if  $x_1, \dots, x_n \in \mathbb{R}^N$ , then

$$\{x_1, \dots, x_n\} = \{x_1\} \cup \dots \cup \{x_n\}$$

is closed.

Arbitrary unions of closed sets are, in general, not closed again.

**Definition 1.4.6.** A point  $x \in \mathbb{R}^N$  is called a *cluster point* of  $S \subset \mathbb{R}^N$  if each neighborhood of  $x$  contains a point  $y \in S \setminus \{x\}$ .

*Examples.*

1. Let  $x \in \mathbb{R}$ . Then, for every  $\epsilon > 0$ , the open interval  $(x - \epsilon, x + \epsilon)$  contains a rational number different from  $x$ . Hence, every real number is a cluster point of  $\mathbb{Q}$ .
2. Let  $S \subset \mathbb{R}^N$  be finite. We claim that  $S$  has *no* cluster points. This is clear if  $S = \emptyset$ , so we can suppose without loss of generality that  $S \neq \emptyset$ . Let  $x \in \mathbb{R}^N$ . If  $x \notin S$ , set  $\epsilon := \min\{\|y - x\| : y \in S\}$ , so that  $\epsilon > 0$  and  $B_\epsilon(x) \cap S = \emptyset$ ; if  $x \in S$ , set  $\epsilon := \min\{\|y - x\| : y \in S \setminus \{x\}\}$ , so that  $\epsilon > 0$  and  $B_\epsilon(x) \cap S = \{x\}$ . In either case,  $x$  cannot be a cluster point of  $S$ .

3. Let

$$S := \left\{ \frac{1}{n} : n \in \mathbb{N} \right\}.$$

Then 0 is a cluster point of  $S$ . Let  $x \in \mathbb{R}$  be any cluster point of  $S$ , and assume that  $x \neq 0$ . If  $x \in S$ , it is of the form  $x = \frac{1}{n}$  for some  $n \in \mathbb{N}$ . Let  $\epsilon := \frac{1}{n} - \frac{1}{n+1}$ , so that  $B_\epsilon(x) \cap S = \{x\}$ . Hence,  $x$  cannot be a cluster point. If  $x \notin S$ , choose  $n_0 \in \mathbb{N}$  such that  $\frac{1}{n_0} < \frac{|x|}{2}$ . This implies that  $\frac{1}{n} < \frac{|x|}{2}$  for all  $n \geq n_0$ . Let

$$\epsilon := \min \left\{ \frac{|x|}{2}, |1 - x|, \dots, \left| \frac{1}{n_0 - 1} - x \right| \right\} > 0.$$

It follows that

$$1, \frac{1}{2}, \dots, \frac{1}{n_0 - 1} \notin B_\epsilon(x)$$

because  $|x - \frac{1}{k}| \geq \epsilon$  for  $k = 1, \dots, n_0 - 1$ . For  $n \geq n_0$ , we have  $|\frac{1}{n} - x| \geq \frac{|x|}{2} \geq \epsilon$ . All in all, we have  $\frac{1}{n} \notin B_\epsilon(x)$  for all  $n \in \mathbb{N}$ . Hence, 0 is the only accumulation point of  $S$ .

**Definition 1.4.7.** A set  $S \subset \mathbb{R}^N$  is bounded if  $S \subset B_r[0]$  for some  $r > 0$ .

**Theorem 1.4.8** (Bolzano–Weierstraß Theorem). *Every bounded, infinite subset  $S \subset \mathbb{R}^N$  has a cluster point.*

*Proof.* Let  $r > 0$  such that  $S \subset B_r[0]$ . It follows that

$$S \subset \underbrace{[-r, r] \times \dots \times [-r, r]}_{N \text{ times}} =: I_1.$$

We can find  $2^N$  closed intervals  $I_1^{(1)}, \dots, I_1^{(2^N)}$  such that  $I_1 = \bigcup_{j=1}^{2^N} I_1^{(j)}$ , where

$$I_1^{(j)} = I_{1,1}^{(j)} \times \dots \times I_{1,N}^{(j)}$$

for  $j = 1, \dots, 2^N$  such that each interval  $I_{1,k}^{(j)}$  has length  $r$ .

Since  $S$  is infinite, there must be  $j_0 \in \{1, \dots, 2^N\}$  such that  $S \cap I_1^{(j_0)}$  is infinite. Let  $I_2 := I_1^{(j_0)}$ .

Inductively, we obtain a decreasing sequence  $I_1, I_2, I_3, \dots$  of closed intervals with the following properties:

- (a)  $S \cap I_n$  is infinite for all  $n \in \mathbb{N}$ ;
- (b) for  $I_n = I_{n,1} \times \dots \times I_{n,N}$  and

$$\ell(I_n) = \max\{\text{length of } I_{n,j} : j = 1, \dots, N\},$$

we have

$$\ell(I_{n+1}) = \frac{1}{2}\ell(I_n) = \frac{1}{4}\ell(I_{n-1}) = \dots = \frac{1}{2^n}\ell(I_1) = \frac{r}{2^{n-1}}.$$

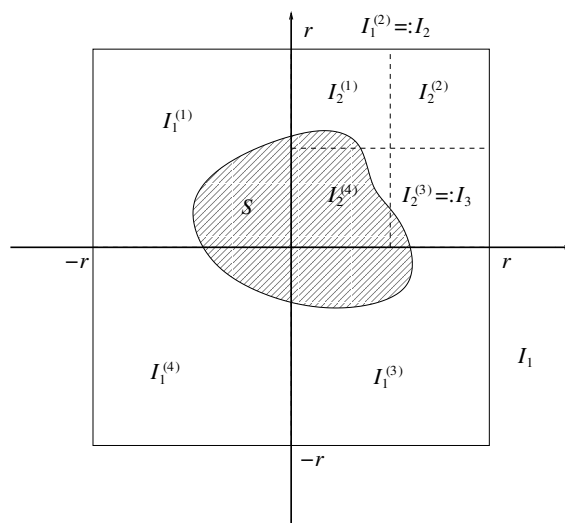

Figure 1.8: Proof of the Bolzano–Weierstraß Theorem

From Theorem 1.3.10, we know that there is  $x \in \bigcap_{n=1}^{\infty} I_n$ .

We claim that  $x$  is a cluster point of  $S$ .

Let  $\epsilon > 0$ . For  $y \in I_n$  note that

$$\max\{|x_j - y_j| : j = 1, \dots, N\} \leq \ell(I_n) = \frac{r}{2^{n-2}}$$

and thus

$$\begin{aligned} \|x - y\| &= \left( \sum_{j=1}^N |x_j - y_j|^2 \right)^{\frac{1}{2}} \\ &\leq \sqrt{N} \max\{|x_j - y_j| : j = 1, \dots, N\} \\ &\leq \frac{\sqrt{N} r}{2^{n-2}}. \end{aligned}$$

Choose  $n \in \mathbb{N}$  so large that  $\frac{\sqrt{N} r}{2^{n-2}} < \epsilon$ . It follows that  $I_n \subset B_\epsilon(x)$ . Since  $S \cap I_n$  is infinite,  $B_\epsilon(x) \cap S$  must be infinite as well; in particular,  $B_\epsilon(x)$  contains at least one point from  $S \setminus \{x\}$ .  $\square$

**Theorem 1.4.9.** *A set  $F \subset \mathbb{R}^N$  is closed if and only if it contains all of its cluster points.*

*Proof.* Suppose that  $F$  is closed. Let  $x \in \mathbb{R}^N$  be a cluster point of  $F$  and assume that  $x \notin F$ . Since  $F^c$  is open, it is a neighborhood of  $x$ . But  $F^c \cap F = \emptyset$  holds by definition.

Suppose conversely that  $F$  contains its cluster points, and let  $x \in \mathbb{R}^N \setminus F$ . Then  $x$  is not a cluster point of  $F$ . Hence, there is  $\epsilon > 0$  such that  $B_\epsilon(x) \cap F \subset \{x\}$ . Since  $x \notin F$ , this means in fact that  $B_\epsilon(x) \cap F = \emptyset$ , i.e.,  $B_\epsilon(x) \subset F^c$ .  $\square$

For our next definition, we first give an example as motivation:

*Example.* Let  $x_0 \in \mathbb{R}^N$  and let  $r > 0$ . Then

$$S_r[x_0] := \{x \in \mathbb{R}^N : \|x - x_0\| = r\}$$

is the the *sphere* centered at  $x_0$  with radius  $r$ . We can think of  $S_r[x_0]$  as the “surface” of  $B_r[x_0]$ .

Suppose that  $x \in S_r[x_0]$ , and let  $\epsilon > 0$ . We claim that both  $B_\epsilon(x) \cap B_r[x_0]$  and  $B_\epsilon(x) \cap B_r[x_0]^c$  are not empty. For  $B_\epsilon(x) \cap B_r[x_0]$ , this is trivial because  $S_r[x_0] \subset B_r[x_0]$ , so that  $x \in B_\epsilon(x) \cap B_r[x_0]$ . Assume that  $B_\epsilon(x) \cap B_r[x_0]^c = \emptyset$ , i.e.,  $B_\epsilon(x) \subset B_r[x_0]$ . Let  $t > 1$ , and set  $y_t := t(x - x_0) + x_0$ . Note that

$$\|y_t - x\| = \|t(x - x_0) + x_0 - x\| = \|(t - 1)(x - x_0)\| = (t - 1)r.$$

Choose  $t < 1 + \frac{\epsilon}{r}$ , then  $y_t \in B_\epsilon(x)$ . On the other hand, we have

$$\|y_t - x_0\| = t\|x - x_0\| > r,$$

so that  $y_t \notin B_r[x_0]$ . Hence,  $B_\epsilon(x) \cap B_r[x_0]^c$  is not empty.

Define the *boundary* of  $B_r[x_0]$  as

$$\partial B_r[x_0] := \{x \in \mathbb{R}^N : B_\epsilon(x) \cap B_r[x_0] \text{ and } B_\epsilon(x) \cap B_r[x_0]^c \text{ are not empty for each } \epsilon > 0\}.$$

By what we have just seen,  $S_r[x_0] \subset \partial B_r[x_0]$  holds. Conversely, suppose that  $x \notin S_r[x_0]$ . Then there are two possibilities, namely  $x \in B_r(x_0)$  or  $x \in B_r[x_0]^c$ . In the first case, we find  $\epsilon > 0$  such that  $B_\epsilon(x) \subset B_r(x_0)$ , so that  $B_\epsilon(x) \cap B_r[x_0]^c = \emptyset$ , and in the second case, we obtain  $\epsilon > 0$  with  $B_\epsilon(x) \subset B_r[x_0]^c$ , so that  $B_\epsilon(x) \cap B_r[x_0] = \emptyset$ . It follows that  $x \notin \partial B_r[x_0]$ .

All in all,  $\partial B_r[x_0]$  is  $S_r[x_0]$ .

This example motivates the following definition:

**Definition 1.4.10.** Let  $S \subset \mathbb{R}^N$ . A point  $x \in \mathbb{R}^N$  is called a *boundary point* of  $S$  if  $B_\epsilon(x) \cap S \neq \emptyset$  and  $B_\epsilon(x) \cap S^c \neq \emptyset$  for each  $\epsilon > 0$ . We let

$$\partial S := \{x \in \mathbb{R}^N : x \text{ is a boundary point of } S\}$$

denote the *boundary* of  $S$ .

*Examples.*

1. Let  $x_0 \in \mathbb{R}^N$ , and let  $r > 0$ . As for  $B_r[x_0]$ , one sees that  $\partial B_r(x_0) = S_r[x_0]$ .
2. Let  $x \in \mathbb{R}$ , and let  $\epsilon > 0$ . Then the interval  $(x - \epsilon, x + \epsilon)$  contains both rational and irrational numbers. Hence,  $x$  is a boundary point of  $\mathbb{Q}$ . Since  $x$  was arbitrary, we conclude that  $\partial \mathbb{Q} = \mathbb{R}$ .

**Proposition 1.4.11.** *Let  $S \subset \mathbb{R}^N$  be any set. Then the following are true:*

- (i)  $\partial S = \partial(S^c)$ ;
- (ii)  $\partial S \cap S = \emptyset$  if and only if  $S$  is open;
- (iii)  $\partial S \subset S$  if and only if  $S$  is closed.

*Proof.* (i): Since  $S^{cc} = S$ , this is immediate from the definition.

(ii): Let  $S$  be open, and let  $x \in S$ . Then there is  $\epsilon > 0$  such that  $B_\epsilon(x) \subset S$ , i.e.,  $B_\epsilon(x) \cap S^c = \emptyset$ . Hence,  $x$  is not a boundary point of  $S$ .

Conversely, suppose that  $\partial S \cap S = \emptyset$ , and let  $x \in S$ . Since  $B_r(x) \cap S \neq \emptyset$  for each  $r > 0$  (it contains  $x$ ), and since  $x$  is not a boundary point, there must be  $\epsilon > 0$  such that  $B_\epsilon(x) \cap S^c = \emptyset$ , i.e.,  $B_\epsilon(x) \subset S$ .

(iii): Let  $S$  be closed. Then  $S^c$  is open, and by (ii),  $\partial S^c \cap S^c = \emptyset$ , i.e.,  $\partial S^c \subset S$ . With (i), we conclude that  $\partial S \subset S$ .

Suppose that  $\partial S \subset S$ , i.e.,  $\partial S \cap S^c = \emptyset$ . With (i) and (ii), this implies that  $S^c$  is open. Hence,  $S$  is closed.  $\square$

**Definition 1.4.12.** Let  $S \subset \mathbb{R}^N$ . Then  $\bar{S}$ , the *closure* of  $S$ , is defined as

$$\bar{S} := S \cup \{x \in \mathbb{R}^N : x \text{ is a cluster point of } S\}.$$

**Theorem 1.4.13.** *Let  $S \subset \mathbb{R}^N$  be any set. Then:*

- (i)  $\bar{S}$  is closed;
- (ii)  $\bar{S}$  is the intersection of all closed sets containing  $S$ ;
- (iii)  $\bar{S} = S \cup \partial S$ .

*Proof.* (i): Let  $x \in \mathbb{R}^N \setminus \bar{S}$ . Then, in particular,  $x$  is not a cluster point of  $S$ . Hence, there is  $\epsilon > 0$  such that  $B_\epsilon(x) \cap S \subset \{x\}$ ; since  $x \notin S$ , we then have automatically that  $B_\epsilon(x) \cap S = \emptyset$ . Since  $B_\epsilon(x)$  is a neighborhood of each of its points, it follows that no point of  $B_\epsilon(x)$  can be a cluster point of  $S$ . Hence,  $B_\epsilon(x)$  lies in the complement of  $\bar{S}$ . Consequently,  $\bar{S}$  is closed.

(ii): Let  $F \subset \mathbb{R}^N$  be closed with  $S \subset F$ . Clearly, each cluster point of  $S$  is a cluster point of  $F$ , so that

$$\bar{S} \subset F \cup \{x \in \mathbb{R}^N : x \text{ is a cluster point of } F\} = F.$$

This proves that  $\bar{S}$  is contained in every closed set containing  $S$ . Since  $\bar{S}$  itself is closed, it equals the intersection of all closed set containing  $S$ .

(iii): By definition, every point in  $\partial S$  not belonging to  $S$  must be a cluster point of  $S$ , so that  $S \cup \partial S \subset \bar{S}$ . Conversely, let  $x \in \bar{S}$  and suppose that  $x \notin S$ , i.e.,  $x \in S^c$ . Then,

for each  $\epsilon > 0$ , we trivially have  $B_\epsilon(x) \cap S^c \neq \emptyset$ , and since  $x$  must be a cluster point, we have  $B_\epsilon(x) \cap S \neq \emptyset$  as well. Hence,  $x$  must be a boundary point of  $S$ .  $\square$

*Examples.*

1. For  $x_0 \in \mathbb{R}$  and  $r > 0$ , we have

$$\overline{B_r(x_0)} = B_r(x_0) \cup \partial B_r(x_0) = B_r(x_0) \cup S_r[x_0] = B_r[x_0].$$

2. As  $\partial\mathbb{Q} = \mathbb{R}$ , we also have  $\overline{\mathbb{Q}} = \mathbb{R}$ .

*Remark.* Theorem 1.4.13 suggests that the notions of cluster point and boundary point of a set  $S$  are related, but they are not the same. For instance, given  $x_0 \in \mathbb{R}^N$  and  $r > 0$ , every point of  $B_r[x_0]$  is a cluster point of  $B_r[x_0]$  whereas  $\partial B_r[x_0] = S_r[x_0]$ . On the other hand, if  $0 \neq S \subset \mathbb{R}^N$  is finite, it is easy to see that  $\partial S = S$  whereas there are no cluster points of  $S$ .

**Definition 1.4.14.** A point  $x \in S \subset \mathbb{R}^N$  is called an *interior point* of  $S$  if there is  $\epsilon > 0$  such that  $B_\epsilon(x) \subset S$ . We let

$$\text{int } S := \{x \in S : x \text{ is an interior point of } S\}$$

denote the *interior* of  $S$ .

**Theorem 1.4.15.** *Let  $S \subset \mathbb{R}^N$  be any set. Then:*

- (i) *int  $S$  is open and equals the union of all open subsets of  $S$ ;*
- (ii) *int  $S = S \setminus \partial S$ .*

*Proof.* For each  $x \in \text{int } S$ , there is  $\epsilon_x > 0$  such that  $B_{\epsilon_x}(x) \subset S$ , so that

$$\text{int } S \subset \bigcup_{x \in \text{int } S} B_{\epsilon_x}(x). \quad (1.5)$$

Let  $y \in \mathbb{R}^N$  be such that there is  $x \in \text{int } S$  such that  $y \in B_{\epsilon_x}(x)$ . Since  $B_{\epsilon_x}(x)$  is open, there is  $\delta_y > 0$  with

$$B_{\delta_y}(y) \subset B_{\epsilon_x}(x) \subset S.$$

It follows that  $y \in \text{int } S$ , so that the inclusion (1.5) is, in fact, an equality. Since the right hand side of (1.5) is open, this proves the first part of (i).

Let  $U \subset S$  be open, and let  $x \in U$ . Then there is  $\epsilon > 0$  such that  $B_\epsilon(x) \subset U \subset S$ , so that  $x \in \text{int } S$ . Hence,  $U \subset \text{int } S$  holds.

For (ii), let  $x \in \text{int } S$ . Then there is  $\epsilon > 0$  such that  $B_\epsilon(x) \subset S$  and thus  $B_\epsilon(x) \cap S^c = \emptyset$ . It follows that  $x \in S \setminus \partial S$ . Conversely, let  $x \in S$  such that  $x \notin \partial S$ . Then there is  $\epsilon > 0$  such that  $B_\epsilon(x) \cap S = \emptyset$  or  $B_\epsilon(x) \cap S^c = \emptyset$ . Since  $x \in B_\epsilon(x) \cap S$ , the first situation cannot occur, so that  $B_\epsilon(x) \cap S^c = \emptyset$ , i.e.,  $B_\epsilon(x) \subset S$ . It follows that  $x$  is an interior point of  $S$ .  $\square$



*Example.* Let  $x_0 \in \mathbb{R}^N$ , and let  $r > 0$ . Then

$$\text{int } B_r[x_0] = B_r[x_0] \setminus S_r[x_0] = B_r(x_0)$$

holds.

**Definition 1.4.16.** An *open cover* of  $S \subset \mathbb{R}^N$  is a family  $\{U_i : i \in \mathbb{I}\}$  of open sets in  $\mathbb{R}^N$  such that  $S \subset \bigcup_{i \in \mathbb{I}} U_i$ .

*Example.* The family  $\{B_r(0) : r > 0\}$  is an open cover for  $\mathbb{R}^N$ .

**Definition 1.4.17.** A set  $K \subset \mathbb{R}^N$  is called *compact* if every open cover  $\{U_i : i \in \mathbb{I}\}$  of  $K$  has a finite subcover, i.e., there are  $i_1, \dots, i_n \in \mathbb{I}$  such that

$$K \subset U_{i_1} \cup \dots \cup U_{i_n}.$$

*Examples.*

1. Every finite set is compact.

*Proof.* Let  $S = \{x_1, \dots, x_n\} \subset \mathbb{R}^N$ , and let  $\{U_i : i \in \mathbb{I}\}$  be an open cover for  $S$ , i.e.,  $x_1, \dots, x_n \in \bigcup_{i \in \mathbb{I}} U_i$ . For  $j = 1, \dots, n$ , there is thus  $i_j \in \mathbb{I}$  such that  $x_j \in U_{i_j}$ . Hence, we have

$$S \subset U_{i_1} \cup \dots \cup U_{i_n}.$$

Hence,  $\{U_{i_1}, \dots, U_{i_n}\}$  is a finite subcover of  $\{U_i : i \in \mathbb{I}\}$ . □

2. The open unit interval  $(0, 1)$  is not compact.

*Proof.* For  $n \in \mathbb{N}$ , let  $U_n := (\frac{1}{n}, 1)$ . Then  $\{U_n : n \in \mathbb{N}\}$  is an open cover for  $(0, 1)$ . Assume that  $(0, 1)$  is compact. Then there are  $n_1, \dots, n_k \in \mathbb{N}$  such that

$$(0, 1) = U_{n_1} \cup \dots \cup U_{n_k}.$$

Without loss of generality, let  $n_1 < \dots < n_k$ , so that

$$(0, 1) = U_{n_1} \cup \dots \cup U_{n_k} = U_{n_k} = \left(\frac{1}{n_k}, 1\right),$$

which is nonsense. □

3. Every compact set  $K \subset \mathbb{R}^N$  is bounded.

*Proof.* Clearly,  $\{B_r(0) : r > 0\}$  is an open cover for  $K$ . Since  $K$  is compact, there are  $0 < r_1 < \dots < r_n$  such that

$$K \subset B_{r_1}(0) \cup \dots \cup B_{r_n}(0) = B_{r_n}(0),$$

which is possible only if  $K$  is bounded. □

**Lemma 1.4.18.** *Every compact set  $K \subset \mathbb{R}^N$  is closed.*

*Proof.* Let  $x \in K^c$ . For  $n \in \mathbb{N}$ , let

$$U_n := \left\{ y \in \mathbb{R}^N : \|y - x\| > \frac{1}{n} \right\} = B_{\frac{1}{n}}[x]^c,$$

so that

$$K \subset \mathbb{R}^N \setminus \{x\} = \bigcup_{n=1}^{\infty} U_n.$$

Since  $K$  is compact, there are  $n_1 < \dots < n_k$  in  $\mathbb{N}$  such that

$$K \subset U_{n_1} \cup \dots \cup U_{n_k} = U_{n_k}.$$

It follows that

$$B_{\frac{1}{n_k}}(x) \subset B_{\frac{1}{n_k}}[x] = U_{n_k}^c \subset K^c.$$

Hence,  $K^c$  is a neighborhood of  $x$ . □

**Lemma 1.4.19.** *Let  $K \subset \mathbb{R}^N$  be compact, and let  $F \subset K$  be closed. Then  $F$  is compact.*

*Proof.* Let  $\{U_i : i \in \mathbb{I}\}$  be an open cover for  $F$ . Then  $\{U_i : i \in \mathbb{I}\} \cup \{\mathbb{R}^N \setminus F\}$  is an open cover for  $K$ . Compactness of  $K$  yields  $i_1, \dots, i_n \in \mathbb{I}$  such that

$$K \subset U_{i_1} \cup \dots \cup U_{i_n} \cup \mathbb{R}^N \setminus F.$$

Since  $F \cap (\mathbb{R}^N \setminus F) = \emptyset$ , it follows that

$$F \subset U_{i_1} \cup \dots \cup U_{i_n}.$$

Since  $\{U_i : i \in \mathbb{I}\}$  is an arbitrary open cover for  $F$ , this entails the compactness of  $F$ . □

**Theorem 1.4.20** (Heine–Borel Theorem). *The following are equivalent for  $K \subset \mathbb{R}^N$ :*

- (i)  $K$  is compact;
- (ii)  $K$  is closed and bounded.

*Proof.* (i)  $\implies$  (ii) is clear (no unbounded set is compact, as seen in the examples, and every compact set is closed by Lemma 1.4.18).

(ii)  $\implies$  (i): As  $K$  is bounded, there is  $r > 0$  such that

$$K \subset B_r(0) \subset [-r, r] \times \dots \times [-r, r] =: I_1.$$

Since  $K$  is closed, it follows from Lemma 1.4.19 that  $K$  is compact if  $I_1$  is. It is therefore enough to show that  $I_1$  is compact.

Let  $\{U_i : i \in \mathbb{I}\}$  be an open cover for  $I_1$ , and assume that it does not have a finite subcover.

As in the proof of the Bolzano–Weierstraß Theorem, we may find closed intervals  $I_1^{(1)}, \dots, I_1^{(2^N)}$  with  $\ell(I_1^{(j)}) = \frac{1}{2} \ell(I_1)$  for  $j = 1, \dots, 2^N$  such that  $I_1 = \bigcup_{j=1}^{2^N} I_1^{(j)}$ . Since  $\{U_i : i \in \mathbb{I}\}$  has no finite subcover for  $I_1$ , there is  $j_0 \in \{1, \dots, 2^N\}$  such that  $\{U_i : i \in \mathbb{I}\}$  has no finite subcover for  $I_1^{(j_0)}$ . Let  $I_2 := I_1^{(j_0)}$ .

Inductively, we thus obtain closed intervals  $I_1 \supset I_2 \supset I_3 \supset \dots$  such that:

$$(a) \quad \ell(I_{n+1}) = \frac{1}{2} \ell(I_n) = \dots = \frac{1}{2^n} \ell(I_1) \text{ for all } n \in \mathbb{N};$$

(b)  $\{U_i : i \in \mathbb{I}\}$  does not have a finite subcover for  $I_n$  for each  $n \in \mathbb{N}$ .

Let  $x \in \bigcap_{n=1}^{\infty} I_n$ , and let  $i_0 \in \mathbb{I}$  be such that  $x \in U_{i_0}$ . Since  $U_{i_0}$  is open, there is  $\epsilon > 0$  such that  $B_\epsilon(x) \subset U_{i_0}$ . Let  $n \in \mathbb{N}$  and  $y \in I_n$ ; it follows that

$$\|y - x\| \leq \sqrt{N} \max_{j=1, \dots, N} |y_j - x_j| \leq \frac{\sqrt{N}}{2^{n-1}} \ell(I_1).$$

Choose  $n \in \mathbb{N}$  so large that  $\frac{\sqrt{N}}{2^{n-1}} \ell(I_1) < \epsilon$ . It follows that

$$I_n \subset B_\epsilon(x) \subset U_{i_0},$$

so that  $\{U_i : i \in \mathbb{I}\}$  has a finite subcover for  $I_n$ .

This is a contradiction. Therefore,  $\{U_i : i \in \mathbb{I}\}$  must have a finite subcover for  $I_1$ .  $\square$

**Definition 1.4.21.** A *disconnection* for  $S \subset \mathbb{R}^N$  is a pair  $\{U, V\}$  of open sets such that:

- (a)  $U \cap S \neq \emptyset \neq V \cap S$ ;
- (b)  $(U \cap S) \cap (V \cap S) = \emptyset$ ;
- (c)  $(U \cap S) \cup (V \cap S) = S$ .

If a disconnection for  $S$  exists,  $S$  is called *disconnected*; otherwise, we say that  $S$  is *connected*.

Note that we do not require that  $U \cap V = \emptyset$ .

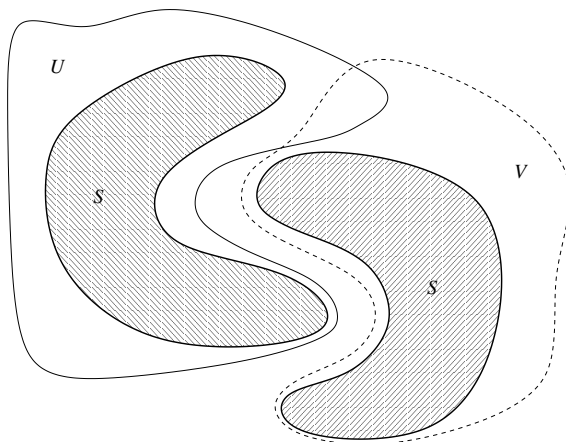
Figure 1.9: A set  $S$  with disconnection  $\{U, V\}$ 

*Examples.*

1.  $\mathbb{Z}$  is disconnected: Choose

$$U := \left(-\infty, \frac{1}{2}\right) \quad \text{and} \quad V := \left(\frac{1}{2}, \infty\right);$$

then  $\{U, V\}$  is a disconnection for  $\mathbb{Z}$ .

2.  $\mathbb{Q}$  is disconnected: A disconnection  $\{U, V\}$  is given by

$$U := (-\infty, \sqrt{2}) \quad \text{and} \quad V := (\sqrt{2}, \infty).$$

3. The closed unit interval  $[0, 1]$  is connected.

*Proof.* We assume that there is a disconnection  $\{U, V\}$  for  $[0, 1]$ ; without loss of generality, suppose that  $0 \in U$ . Since  $U$  is open, there is  $\epsilon_0 > 0$ —which we can suppose without loss of generality to be from  $(0, 1)$ —such that  $(-\epsilon_0, \epsilon_0) \subset U$  and thus  $[0, \epsilon_0) \subset U \cap [0, 1]$ . Let  $t_0 := \sup\{\epsilon > 0 : [0, \epsilon) \subset U \cap [0, 1]\}$ , so that  $0 < \epsilon_0 \leq t_0 \leq 1$ . Assume that  $t_0 \in V$ . We can choose  $\delta > 0$  such that  $t_0 - \delta > 0$  and  $(t_0 - \delta, t_0 + \delta) \subset V$ . This, in particular, means that  $[0, \epsilon) \not\subset U \cap [0, 1]$  for all  $\epsilon > t_0 - \delta$ , which contradicts the very definition of  $t_0$ .

Assume therefore that  $t_0 \in U$ . If  $t_0 < 1$ , we can choose  $\theta > 0$  such that  $t_0 + \theta < 1$  and  $(t_0 - \theta, t_0 + \theta) \subset U$ : this also contradicts the definition of  $t_0$ . Hence, assume that  $t_0 = 1$ . But this implies that  $V \cap [0, 1] = \emptyset$ , which contradicts the definition of a disconnection.

All in all, there is no disconnection for  $[0, 1]$ . □

**Theorem 1.4.22.** *Let  $C \subset \mathbb{R}^N$  be convex. Then  $C$  is connected.*

*Proof.* Assume that there is a disconnection  $\{U, V\}$  for  $C$ . Let  $x \in U \cap C$  and let  $y \in V \cap C$ . Let

$$\tilde{U} := \{t \in \mathbb{R} : tx + (1-t)y \in U\}$$

and

$$\tilde{V} := \{t \in \mathbb{R} : tx + (1-t)y \in V\}.$$

We claim that  $\tilde{U}$  is open. To see this, let  $t_0 \in \tilde{U}$ . It follows that  $x_0 := t_0x + (1-t_0)y \in U$ . Since  $U$  is open, there is  $\epsilon > 0$  such that  $B_\epsilon(x_0) \subset U$ . For  $t \in \mathbb{R}$  with  $|t - t_0| < \frac{\epsilon}{\|x\| + \|y\|}$ , we thus have

$$\begin{aligned} \|(tx + (1-t)y) - x_0\| &= \|(tx + (1-t)y) - (t_0x + (1-t_0)y)\| \\ &= \|(t-t_0)x - (t-t_0)y\| \\ &\leq |t-t_0|(\|x\| + \|y\|) \\ &< \epsilon \end{aligned}$$

and therefore  $tx + (1-t)y \in B_\epsilon(x_0) \subset U$ . It follows that  $t \in \tilde{U}$ .

Analogously, one sees that  $\tilde{V}$  is open.

The following hold for  $\{\tilde{U}, \tilde{V}\}$ :

- (a)  $\tilde{U} \cap [0, 1] \neq \emptyset \neq \tilde{V} \cap [0, 1]$ : since  $x = 1x + (1-1)y \in U$  and  $y = 0x + (1-0)y \in V$ , we have  $1 \in \tilde{U}$  and  $0 \in \tilde{V}$ ;
- (b)  $(\tilde{U} \cap [0, 1]) \cap (\tilde{V} \cap [0, 1]) = \emptyset$ : if  $t \in (\tilde{U} \cap [0, 1]) \cap (\tilde{V} \cap [0, 1])$ , then  $tx + (1-t)y \in (U \cap C) \cap (V \cap C)$ , which is impossible;
- (c)  $(\tilde{U} \cap [0, 1]) \cup (\tilde{V} \cap [0, 1]) = [0, 1]$ : for  $t \in [0, 1]$ , we have  $tx + (1-t)y \in C = (U \cap C) \cup (V \cap C)$ —due to the convexity of  $C$ —, so that  $t \in (\tilde{U} \cap [0, 1]) \cup (\tilde{V} \cap [0, 1])$ .

Hence,  $\{\tilde{U}, \tilde{V}\}$  is a disconnection for  $[0, 1]$ , which is impossible.  $\square$

*Example.*  $\emptyset$ ,  $\mathbb{R}^N$ , and all closed and open balls and intervals in  $\mathbb{R}^N$  are connected.

**Corollary 1.4.23.** *The only subsets of  $\mathbb{R}^N$  which are both open and closed are  $\emptyset$  and  $\mathbb{R}^N$ .*

*Proof.* Let  $U \subset \mathbb{R}^N$  be both open and closed, and assume that  $\emptyset \neq U \neq \mathbb{R}^N$ . Then  $\{U, U^c\}$  would be a disconnection for  $\mathbb{R}^N$ .  $\square$

**Exercises**

1. Let  $S \subset \mathbb{R}^N$ . Show that  $x \in \mathbb{R}^N$  is a cluster point of  $S$  if and only if each neighborhood of  $x$  contains an infinite number of points in  $S$ .
2. Let  $S \subset \mathbb{R}^N$  be any set. Show that  $\partial S$  is closed.
3. For  $j = 1, \dots, N$ , let  $I_j = [a_j, b_j]$  with  $a_j < b_j$ , and let  $I := I_1 \times \dots \times I_N$ . Determine  $\partial I$ . (*Hint*: Draw a sketch for  $N = 2$  or  $N = 3$ .)
4. Let  $S_1, \dots, S_n \subset \mathbb{R}^N$ . Show that  $\partial(S_1 \cup \dots \cup S_n) \subset \partial S_1 \cup \dots \cup \partial S_n$ . Does equality necessarily hold?
5. Which of the sets below are compact?
  - (a)  $\{x \in \mathbb{R}^N : r \leq \|x\| \leq R\}$  with  $0 < r < R$ ;
  - (b)  $\{x \in \mathbb{R}^N : r < \|x\| \leq R\}$  with  $0 < r < R$ ;
  - (c)  $\overline{\{(t, \sin \frac{1}{t}) : t \in (0, 2022]\}}$ ;
  - (d)  $\{\frac{1}{n} : n \in \mathbb{N}\}$ ;
  - (e)  $\{\frac{1}{n} : n \in \mathbb{N}\} \cup \{0\}$ .

Justify your answers.

6. Show that:
  - (a) if  $U_1 \subset \mathbb{R}^N$  and  $U_2 \subset \mathbb{R}^M$  are open, then so is  $U_1 \times U_2 \subset \mathbb{R}^{N+M}$ ;
  - (b) if  $F_1 \subset \mathbb{R}^N$  and  $F_2 \subset \mathbb{R}^M$  are closed, then so is  $F_1 \times F_2 \subset \mathbb{R}^{N+M}$ ;
  - (c) if  $K_1 \subset \mathbb{R}^N$  and  $K_2 \subset \mathbb{R}^M$  are compact, then so is  $K_1 \times K_2 \subset \mathbb{R}^{N+M}$ .
7. Show that a subset  $K$  of  $\mathbb{R}^N$  is compact if and only if it has the *finite intersection property*, i.e., if  $\{F_i : i \in \mathbb{I}\}$  is a family of closed sets in  $\mathbb{R}^N$  such that  $K \cap \bigcap_{i \in \mathbb{I}} F_i = \emptyset$ , then there are  $i_1, \dots, i_n \in \mathbb{I}$  such that  $K \cap F_{i_1} \cap \dots \cap F_{i_n} = \emptyset$ .
8. A set  $S \subset \mathbb{R}^N$  is called *star shaped* if there is  $x_0 \in S$  such that  $tx_0 + (1-t)x \in S$  for all  $x \in S$  and  $t \in [0, 1]$ . Show that every star shaped set is connected, and give an example of a star shaped set that fails to be convex.
9. Let  $C \subset \mathbb{R}^N$  be connected. Show that  $\overline{C}$  is also connected.
10. Show that:
  - (a) if  $\mathcal{C}$  is a family of connected subsets of  $\mathbb{R}^N$  such that  $\bigcap_{C \in \mathcal{C}} C \neq \emptyset$ , then  $\bigcup_{C \in \mathcal{C}} C$  is connected;

(b) if  $C_1 \subset \mathbb{R}^{N_1}$  and  $C_2 \subset \mathbb{R}^{N_2}$  are connected, then so is  $C_1 \times C_2 \subset \mathbb{R}^{N_1+N_2}$ .

(*Hint for (b)*: Argue that we can suppose that  $C_1$  and  $C_2$  are not empty, and fix  $x_2 \in C_2$ ; then apply (a) to  $\mathcal{C} := \{(C_1 \times \{x_2\}) \cup (\{x_1\} \times C_2) : x_1 \in C_1\}$ .)

11. For  $\epsilon \in (0, 1)$ , determine whether or not the set

$$\{(x, y, z) \in \mathbb{R}^3 : 1 \leq x^2 + y^2 \leq 4, z^2 \in [\epsilon, 1]\}$$

is (a) open, (b) closed, (c) compact, or (d) connected.

12. Let  $\emptyset \neq S \subset \mathbb{R}^N$  be arbitrary, and let  $\emptyset \neq U \subset \mathbb{R}^N$  be open. Show that

$$S + U := \{x + y : x \in S, y \in U\}$$

is open.

## Chapter 2

# Limits and Continuity

### 2.1 Limits of Sequences

**Definition 2.1.1.** A *sequence* in a set  $S$  is a function  $s: \mathbb{N} \rightarrow S$ .

When dealing with a sequence  $s: \mathbb{N} \rightarrow S$ , we prefer to write  $s_n$  instead of  $s(n)$  and denote the whole sequence  $s$  by  $(s_n)_{n=1}^{\infty}$ . We shall also consider, when the occasion arises, sequences indexed over subsets of  $\mathbb{Z}$  other than  $\mathbb{N}$ , e.g.,  $\{n \in \mathbb{Z} : n \geq -333\}$ .

**Definition 2.1.2.** A sequence  $(x_n)_{n=1}^{\infty}$  in  $\mathbb{R}^N$  *converges* or is *convergent* to  $x \in \mathbb{R}^N$  if, for each neighborhood  $U$  of  $x$ , there is  $n_U \in \mathbb{N}$  such that  $x_n \in U$  for all  $n \geq n_U$ . The vector  $x$  is called the *limit* of  $(x_n)_{n=1}^{\infty}$ . A sequence that does not converge is said to *diverge* or to be *divergent*.

Equivalently, the sequence  $(x_n)_{n=1}^{\infty}$  converges to  $x \in \mathbb{R}^N$  if, for each  $\epsilon > 0$ , there is  $n_{\epsilon} \in \mathbb{N}$  such that  $\|x_n - x\| < \epsilon$  for all  $n \geq n_{\epsilon}$ .

If a sequence  $(x_n)_{n=1}^{\infty}$  in  $\mathbb{R}^N$  converges to  $x \in \mathbb{R}^N$ , we write  $x = \lim_{n \rightarrow \infty} x_n$  or  $x_n \xrightarrow{n \rightarrow \infty} x$  or simply  $x_n \rightarrow x$ .

**Proposition 2.1.3.** *Every sequence in  $\mathbb{R}^N$  has at most one limit.*

*Proof.* Let  $(x_n)_{n=1}^{\infty}$  be a sequence in  $\mathbb{R}^N$  with limits  $x, y \in \mathbb{R}^N$ . Assume that  $x \neq y$ , and set  $\epsilon := \frac{\|x-y\|}{2}$ .

Since  $x = \lim_{n \rightarrow \infty} x_n$ , there is  $n_1 \in \mathbb{N}$  such that  $\|x_n - x\| < \epsilon$  for  $n \geq n_1$ , and since also  $y = \lim_{n \rightarrow \infty} x_n$ , there is  $n_2 \in \mathbb{N}$  such that  $\|x_n - y\| < \epsilon$  for  $n \geq n_2$ . For  $n \geq \max\{n_1, n_2\}$ , we then have

$$\|x - y\| \leq \|x - x_n\| + \|x_n - y\| < 2\epsilon = \|x - y\|,$$

which is impossible. □



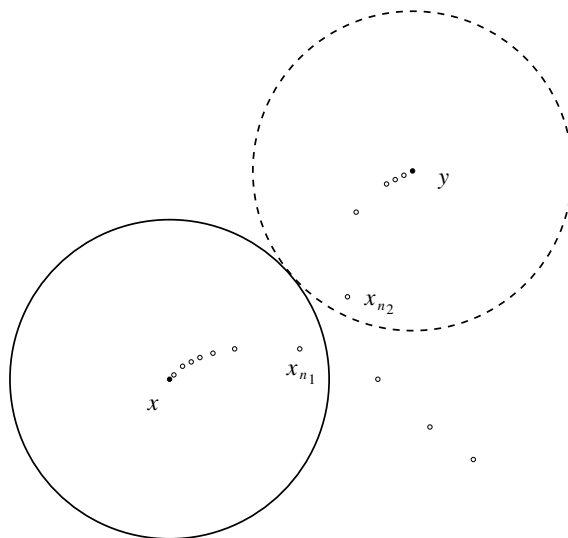

Figure 2.1: Uniqueness of the limit

We call a sequence  $(x_n)_{n=1}^{\infty}$  *bounded*

**Proposition 2.1.4.** *Every convergent sequence in  $\mathbb{R}^N$  is bounded.*

We omit the proof which is almost verbatim like in the one-dimensional case.

**Theorem 2.1.5.** *Let  $(x_n)_{n=1}^{\infty} = \left( (x_n^{(1)}, \dots, x_n^{(N)}) \right)_{n=1}^{\infty}$  be a sequence in  $\mathbb{R}^N$ . Then the following are equivalent for  $x = (x^{(1)}, \dots, x^{(N)})$ :*

- (i)  $\lim_{n \rightarrow \infty} x_n = x$ ;
- (ii)  $\lim_{n \rightarrow \infty} x_n^{(j)} = x^{(j)}$  for  $j = 1, \dots, N$ .

*Proof.* (i)  $\implies$  (ii): Let  $\epsilon > 0$ . Then there is  $n_{\epsilon} \in \mathbb{N}$  such that  $\|x_n - x\| < \epsilon$  for all  $n \geq n_{\epsilon}$ , so that

$$\left| x_n^{(j)} - x^{(j)} \right| \leq \|x_n - x\| < \epsilon$$

holds for all  $n \geq n_{\epsilon}$  and for all  $j = 1, \dots, N$ . This proves (ii).

(ii)  $\implies$  (i): Let  $\epsilon > 0$ . For each  $j = 1, \dots, N$ , there is  $n_{\epsilon}^{(j)} \in \mathbb{N}$  such that

$$\left| x_n^{(j)} - x^{(j)} \right| < \frac{\epsilon}{\sqrt{N}}$$

holds for all  $j = 1, \dots, N$  and for all  $n \geq n_{\epsilon}^{(j)}$ . Let  $n_{\epsilon} := \max \{ n_{\epsilon}^{(1)}, \dots, n_{\epsilon}^{(N)} \}$ . It follows that

$$\max_{j=1, \dots, N} \left| x_n^{(j)} - x^{(j)} \right| < \frac{\epsilon}{\sqrt{N}}$$

and thus

$$\|x_n - x\| \leq \sqrt{N} \max_{j=1, \dots, N} \left| x_n^{(j)} - x^{(j)} \right| < \epsilon$$

for all  $n \geq n_{\epsilon}$ . □

*Examples.*

1. The sequence

$$\left( \frac{1}{n}, 3, \frac{3n^2 - 4}{n^2 + 2n} \right)_{n=1}^{\infty}$$

converges to  $(0, 3, 3)$ , because  $\frac{1}{n} \rightarrow 0$ ,  $3 \rightarrow 3$  and  $\frac{3n^2 - 4}{n^2 + 2n} \rightarrow 3$  in  $\mathbb{R}$ .

2. The sequence

$$\left( \frac{1}{n^3 + 3n}, (-1)^n \right)_{n=1}^{\infty}$$

diverges because  $((-1)^n)_{n=1}^{\infty}$  does not converge in  $\mathbb{R}$ .

Since convergence in  $\mathbb{R}^N$  is nothing but coordinatewise convergence, the following is a straightforward consequence of the limit rules in  $\mathbb{R}$ :

**Proposition 2.1.6** (Limit Rules). *Let  $(x_n)_{n=1}^{\infty}$ ,  $(y_n)_{n=1}^{\infty}$  be convergent sequences in  $\mathbb{R}^N$ , and let  $(\lambda_n)_{n=1}^{\infty}$  be a convergent sequence in  $\mathbb{R}$ . Then the sequences  $(x_n + y_n)_{n=1}^{\infty}$ ,  $(\lambda_n x_n)_{n=1}^{\infty}$ , and  $(x_n \cdot y_n)_{n=1}^{\infty}$  are also convergent such that:*

$$\begin{aligned} \lim_{n \rightarrow \infty} (x_n + y_n) &= \lim_{n \rightarrow \infty} x_n + \lim_{n \rightarrow \infty} y_n, \\ \lim_{n \rightarrow \infty} \lambda_n x_n &= \left( \lim_{n \rightarrow \infty} \lambda_n \right) \left( \lim_{n \rightarrow \infty} x_n \right) \end{aligned}$$

and

$$\lim_{n \rightarrow \infty} (x_n \cdot y_n) = \left( \lim_{n \rightarrow \infty} x_n \right) \cdot \left( \lim_{n \rightarrow \infty} y_n \right).$$

**Definition 2.1.7.** Let  $(s_n)_{n=1}^{\infty}$  be a sequence in a set  $S$ , and let  $n_1 < n_2 < \dots$  be in  $\mathbb{N}$ . Then  $(s_{n_k})_{k=1}^{\infty}$  is called a *subsequence* of  $(s_n)_{n=1}^{\infty}$ .

As in  $\mathbb{R}$ , we have:

**Theorem 2.1.8.** *Every bounded sequence in  $\mathbb{R}^N$  has a convergent subsequence.*

*Proof.* Let  $(x_n)_{n=1}^{\infty}$  be a bounded sequence in  $\mathbb{R}^N$ , and let  $S := \{x_n : n \in \mathbb{N}\}$ .

If  $S$  is finite,  $(x_n)_{n=1}^{\infty}$  obviously has a constant and thus convergent subsequence.

Suppose therefore that  $S$  is infinite. By the Bolzano–Weierstraß Theorem, it therefore has a cluster point  $x$ . Choose  $n_1 \in \mathbb{N}$  such that  $x_{n_1} \in B_1(x) \setminus \{x\}$ . Suppose now that  $n_1 < n_2 < \dots < n_k$  have already been constructed such that

$$x_{n_j} \in B_{\frac{1}{j}}(x) \setminus \{x\}$$

for  $j = 1, \dots, k$ . Let

$$\epsilon := \min \left\{ \frac{1}{k+1}, \|x_l - x\| : l = 1, \dots, n_k \text{ and } x_l \neq x \right\}.$$

Then there is  $n_{k+1} \in \mathbb{N}$  such that  $x_{n_{k+1}} \in B_\epsilon(x) \setminus \{x\}$ . By the choice of  $\epsilon$ , it is clear that  $x_{n_{k+1}} \neq x_l$  for  $l = 1, \dots, n_k$ , so that that  $n_{k+1} > n_k$ .

The subsequence  $(x_{n_k})_{k=1}^\infty$  obtained in this fashion satisfies

$$\|x_{n_k} - x\| < \frac{1}{k}$$

for all  $k \in \mathbb{N}$ , so that  $x = \lim_{k \rightarrow \infty} x_{n_k}$ .  $\square$

**Definition 2.1.9.** A sequence  $(x_n)_{n=1}^\infty$  in  $\mathbb{R}$  is called *decreasing* if  $x_1 \geq x_2 \geq x_3 \geq \dots$  and *increasing* if  $x_1 \leq x_2 \leq x_3 \leq \dots$ . It is called *monotone* if it is increasing or decreasing.

**Theorem 2.1.10.** *A monotone sequence converges if and only if it is bounded.*

*Proof.* Let  $(x_n)_{n=1}^\infty$  be a bounded, monotone sequence. Without loss of generality, suppose that  $(x_n)_{n=1}^\infty$  is increasing. By Theorem 2.1.8,  $(x_n)_{n=1}^\infty$  has a subsequence  $(x_{n_k})_{k=1}^\infty$  which converges. Let  $x := \lim_{k \rightarrow \infty} x_{n_k}$ . We will show that actually  $x = \lim_{n \rightarrow \infty} x_n$ .

Let  $\epsilon > 0$ . Then there is  $k_\epsilon \in \mathbb{N}$  such that

$$x - x_{n_k} = |x_{n_k} - x| < \epsilon,$$

i.e.,

$$x - \epsilon < x_{n_k} < x + \epsilon$$

for all  $k \geq k_\epsilon$ . Let  $n_\epsilon := n_{k_\epsilon}$ , and let  $n \geq n_\epsilon$ . Pick  $m \in \mathbb{N}$  be such that  $n_m \geq n$ , and note that  $x_{n_\epsilon} \leq x_n \leq x_{n_m}$ , so that

$$x - \epsilon < x_{n_\epsilon} \leq x_n \leq x_{n_m} < x + \epsilon,$$

i.e.,

$$|x - x_n| < \epsilon.$$

This means that indeed  $x = \lim_{n \rightarrow \infty} x_n$ .  $\square$

*Example.* Let  $\theta \in (0, 1)$ , so that

$$0 < \theta^{n+1} = \theta \theta^n < \theta^n \leq 1$$

for all  $n \in \mathbb{N}$ . Hence, the sequence  $(\theta^n)_{n=1}^\infty$  is bounded and decreasing and thus convergent. Since

$$\lim_{n \rightarrow \infty} \theta^n = \lim_{n \rightarrow \infty} \theta^{n+1} = \theta \lim_{n \rightarrow \infty} \theta^n,$$

it follows that  $\lim_{n \rightarrow \infty} \theta^n = 0$ .

**Theorem 2.1.11.** *The following are equivalent for a set  $F \subset \mathbb{R}^N$ :*

- (i)  $F$  is closed;

(ii) for each sequence  $(x_n)_{n=1}^{\infty}$  in  $F$  with limit  $x \in \mathbb{R}^N$ , we already have  $x \in F$ .

*Proof.* (i)  $\implies$  (ii): Let  $(x_n)_{n=1}^{\infty}$  be a convergent sequence in  $F$  with limit  $x \in \mathbb{R}^N$ . Assume that  $x \notin F$ , i.e.,  $x \in F^c$ . Since  $F^c$  is open, there is  $\epsilon > 0$  such that  $B_{\epsilon}(x) \subset F^c$ . Since  $x = \lim_{n \rightarrow \infty} x_n$ , there is  $n_{\epsilon} \in \mathbb{N}$  such that  $\|x_n - x\| < \epsilon$  for all  $n \geq n_{\epsilon}$ . But this, in turn, means that  $x_n \in B_{\epsilon}(x) \subset F^c$  for  $n \geq n_{\epsilon}$ , which is absurd.

(ii)  $\implies$  (i): Assume that  $F$  is not closed, i.e.,  $F^c$  is not open. Hence, there is  $x \in F^c$  such that  $B_{\epsilon}(x) \cap F \neq \emptyset$  for all  $\epsilon > 0$ . In particular, there is, for each  $n \in \mathbb{N}$ , an element  $x_n \in F$  with  $\|x_n - x\| < \frac{1}{n}$ . It follows that  $x = \lim_{n \rightarrow \infty} x_n$  even though  $(x_n)_{n=1}^{\infty}$  lies in  $F$  whereas  $x \notin F$ .  $\square$

*Example.* The set

$$F = \{(x_1, \dots, x_N) \in \mathbb{R}^N : x_1 - x_2 - \dots - x_N \in [0, 1]\}$$

is closed. To see this, let  $(x_n)_{n=1}^{\infty}$  be a sequence in  $F$  which converges to some  $x \in \mathbb{R}^N$ . We have

$$x_{n,1} - x_{n,2} - \dots - x_{n,N} \in [0, 1]$$

for  $n \in \mathbb{N}$ . Since  $[0, 1]$  is closed this means that

$$x_1 - x_2 - \dots - x_N = \lim_{n \rightarrow \infty} (x_{n,1} - x_{n,2} - \dots - x_{n,N}) \in [0, 1],$$

so that  $x \in F$ .

**Theorem 2.1.12.** *The following are equivalent for a set  $K \subset \mathbb{R}^N$ :*

- (i)  $K$  is compact;
- (ii) every sequence in  $K$  has a subsequence that converges to a point in  $K$ .

*Proof.* (i)  $\implies$  (ii): Let  $(x_n)_{n=1}^{\infty}$  be a sequence in  $K$ , which is then necessarily bounded. Hence, it has a convergent subsequence with limit, say  $x \in \mathbb{R}^N$ . Since  $K$  is also closed, it follows from Theorem 2.1.11 that  $x \in K$ .

(ii)  $\implies$  (i): Assume that  $K$  is not compact. By the Heine–Borel theorem, this leaves two cases:

*Case 1:*  $K$  is not bounded. In this case, there is, for each  $n \in \mathbb{N}$ , and element  $x_n \in K$  with  $\|x_n\| \geq n$ . Hence, every subsequence of  $(x_n)_{n=1}^{\infty}$  is unbounded and thus diverges.

*Case 2:*  $K$  is not closed. By Theorem 2.1.11, there is a sequence  $(x_n)_{n=1}^{\infty}$  in  $K$  that converges to a point  $x \in K^c$ . Since every subsequence of  $(x_n)_{n=1}^{\infty}$  converges to  $x$  as well, this violates (ii).  $\square$

**Corollary 2.1.13.** *Let  $\emptyset \neq F \subset \mathbb{R}^N$  be closed, and let  $\emptyset \neq K \subset \mathbb{R}^N$  be compact such that*

$$\inf\{\|x - y\| : x \in K, y \in F\} = 0.$$

*Then  $F$  and  $K$  have non-empty intersection.*

This is wrong if  $K$  is only required to be closed, but not necessarily compact:

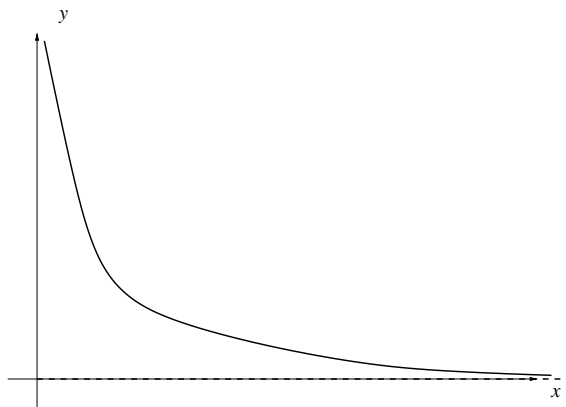

Figure 2.2: Two closed sets in  $\mathbb{R}^2$  with distance zero, but empty intersection

*Proof.* For each  $n \in \mathbb{N}$ , choose  $x_n \in K$  and  $y_n \in F$  such that  $\|x_n - y_n\| < \frac{1}{n}$ . By Theorem 2.1.12,  $(x_n)_{n=1}^{\infty}$  has a subsequence  $(x_{n_k})_{k=1}^{\infty}$  converging to  $x \in K$ . Since  $\lim_{n \rightarrow \infty} (x_n - y_n) = 0$ , it follows that

$$x = \lim_{k \rightarrow \infty} x_{n_k} = \lim_{k \rightarrow \infty} ((x_{n_k} - y_{n_k}) + y_{n_k}) = \lim_{k \rightarrow \infty} y_{n_k}$$

and thus, from Theorem 2.1.11,  $x \in F$  holds as well.  $\square$

**Definition 2.1.14.** A sequence  $(x_n)_{n=1}^{\infty}$  in  $\mathbb{R}^N$  is called a *Cauchy sequence* if, for each  $\epsilon > 0$ , there is  $n_{\epsilon} \in \mathbb{N}$  such that  $\|x_n - x_m\| < \epsilon$  for  $n, m \geq n_{\epsilon}$ .

**Theorem 2.1.15.** *A sequence in  $\mathbb{R}^N$  is a Cauchy sequence if and only if it converges.*

*Proof.* Let  $(x_n)_{n=1}^{\infty}$  be a sequence in  $\mathbb{R}^N$  with limit  $x \in \mathbb{R}^N$ . Let  $\epsilon > 0$ . Then there is  $n_{\epsilon} \in \mathbb{N}$  such that  $\|x_n - x\| < \frac{\epsilon}{2}$  for all  $n \geq n_{\epsilon}$ . It follows that

$$\|x_n - x_m\| \leq \|x_n - x\| + \|x - x_m\| < \frac{\epsilon}{2} + \frac{\epsilon}{2} = \epsilon$$

for  $n, m \geq n_{\epsilon}$ . Hence,  $(x_n)_{n=1}^{\infty}$  is a Cauchy sequence.

Conversely, suppose that  $(x_n)_{n=1}^{\infty}$  is a Cauchy sequence. Then there is  $n_1 \in \mathbb{N}$  such that  $\|x_n - x_m\| < 1$  for all  $n, m \geq n_1$ . For  $n \geq n_1$ , this means in particular that

$$\|x_n\| \leq \|x_n - x_{n_1}\| + \|x_{n_1}\| < 1 + \|x_{n_1}\|.$$

Let

$$C := \max\{\|x_1\|, \dots, \|x_{n_1-1}\|, 1 + \|x_{n_1}\|\}.$$

Then it is immediate that  $\|x_n\| \leq C$  for all  $n \in \mathbb{N}$ . Hence,  $(x_n)_{n=1}^\infty$  is bounded and thus has a convergent subsequence, say  $(x_{n_k})_{k=1}^\infty$ . Let  $x := \lim_{k \rightarrow \infty} x_{n_k}$ , and let  $\epsilon > 0$ . Let  $n_0 \in \mathbb{N}$  be such that  $\|x_n - x_{n_0}\| < \frac{\epsilon}{2}$  for  $n \geq n_0$ , and let  $k_\epsilon \in \mathbb{N}$  be such that  $\|x_{n_k} - x\| < \frac{\epsilon}{2}$  for  $k \geq k_\epsilon$ . Let  $n_\epsilon := n_{\max\{k_\epsilon, n_0\}}$ . Then it follows that

$$\|x_n - x\| \leq \underbrace{\|x_n - x_{n_\epsilon}\|}_{< \frac{\epsilon}{2}} + \underbrace{\|x_{n_\epsilon} - x\|}_{< \frac{\epsilon}{2}} < \epsilon$$

for  $n \geq n_\epsilon$ . □

*Example.* For  $n \in \mathbb{N}$ , let

$$s_n := \sum_{k=1}^n \frac{1}{k}.$$

It follows that

$$|s_{2n} - s_n| = \sum_{k=n+1}^{2n} \frac{1}{k} \geq \sum_{k=n+1}^{2n} \frac{1}{2n} = \frac{1}{2},$$

so that  $(s_n)_{n=1}^\infty$  cannot be a Cauchy sequence and thus has to diverge. Since  $(s_n)_{n=1}^\infty$  is increasing, this does in fact mean that it must be unbounded.

### Exercises

1. Use induction to prove *Bernoulli's Inequality*, i.e.,

$$(1 + x)^n \geq 1 + nx$$

for  $n \in \mathbb{N}_0$  and  $x \geq -1$ . Conclude that, if  $\theta > 1$  and  $R \in \mathbb{R}$ , there is  $n \in \mathbb{N}$  such that  $\theta^n > R$ . Conclude that the sequence  $(\theta^n)_{n=1}^\infty$  does not converge.

2. Let  $(x_n)_{n=1}^\infty$  be a convergent sequence in  $\mathbb{R}^N$  with limit  $x$ . Show that  $\{x_n : n \in \mathbb{N}\} \cup \{x\}$  is compact.
3. Let  $(x_n)_{n=1}^\infty$  be a sequence in  $\mathbb{R}^N$  such that there is  $\theta \in (0, 1)$  with

$$\|x_{n+2} - x_{n+1}\| \leq \theta \|x_{n+1} - x_n\|$$

for  $n \in \mathbb{N}$ . Show that  $(x_n)_{n=1}^\infty$  converges.

(*Hint:* Show first that

$$\|x_{n+1} - x_n\| \leq \theta^{n-1} \|x_2 - x_1\|$$

for  $n \in \mathbb{N}$ , and then use this and the fact that  $\sum_{n=0}^\infty \theta^n$  converges to show that  $(x_n)_{n=1}^\infty$  is a Cauchy sequence.)

4. Let  $S \subset \mathbb{R}^N$ , and let  $x \in \overline{S}$ . Show that  $x \in \overline{S}$  if and only if there is a sequence  $(x_n)_{n=1}^\infty$  in  $S$  such that  $x = \lim_{n \rightarrow \infty} x_n$ .

## 2.2 Limits of Functions

We define the limit of a function (at a point) through limits of sequences:

**Definition 2.2.1.** Let  $\emptyset \neq D \subset \mathbb{R}^N$ , let  $f: D \rightarrow \mathbb{R}^M$  be a function, and let  $x_0 \in \overline{D}$ . Then  $L \in \mathbb{R}^M$  is called the *limit of  $f$  for  $x \rightarrow x_0$* —in symbols:  $L = \lim_{x \rightarrow x_0} f(x)$ —if  $\lim_{n \rightarrow \infty} f(x_n) = L$  for *each* sequence  $(x_n)_{n=1}^\infty$  in  $D$  with  $\lim_{n \rightarrow \infty} x_n = x_0$ .

It is important that  $x_0 \in \overline{D}$ : otherwise there are not sequences in  $D$  converging to  $x_0$ . For example,  $\lim_{x \rightarrow -1} \sqrt{x}$  is simply meaningless.

*Examples.*

1. Let  $D = [0, \infty)$ , and let  $f(x) = \sqrt{x}$ . Let  $(x_n)_{n=1}^\infty$  be a sequence in  $D$  with  $\lim_{n \rightarrow \infty} x_n = x_0$ . For  $n \in \mathbb{N}$ , we have

$$|\sqrt{x_n} - \sqrt{x_0}|^2 \leq |\sqrt{x_n} - \sqrt{x_0}|(\sqrt{x_n} + \sqrt{x_0}) = |x_n - x_0|.$$

Let  $\epsilon > 0$ , and choose  $n_\epsilon \in \mathbb{N}$  such that  $|x_n - x_0| < \epsilon^2$  for  $n \geq n_\epsilon$ . It follows that

$$|\sqrt{x_n} - \sqrt{x_0}| < \epsilon$$

for  $n \geq n_\epsilon$ . Since  $\epsilon > 0$  was arbitrary,  $\lim_{n \rightarrow \infty} \sqrt{x_n} = \sqrt{x_0}$  holds. Hence, we have  $\lim_{x \rightarrow x_0} \sqrt{x} = \sqrt{x_0}$ .

2. Let  $D = (0, \infty)$ , and let  $f(x) = \frac{1}{x}$ . Let  $(x_n)_{n=1}^\infty$  be a sequence in  $D$  with  $\lim_{n \rightarrow \infty} x_n = 0$ . Let  $R > 0$ . Then there is  $n_0 \in \mathbb{N}$  such that  $x_{n_0} < \frac{1}{R}$  and thus  $f(x_{n_0}) = \frac{1}{x_{n_0}} > R$ . Hence, the sequence  $(f(x_n))_{n=1}^\infty$  is unbounded and thus divergent. Consequently,  $\lim_{x \rightarrow 0} f(x)$  does not exist.

3. Let

$$f: \mathbb{R}^2 \setminus \{(0, 0)\} \rightarrow \mathbb{R}, \quad (x, y) \mapsto \frac{xy}{x^2 + y^2}.$$

Let  $x_n = (\frac{1}{n}, \frac{1}{n})$ , so that  $\lim_{n \rightarrow \infty} x_n = 0$ . Then

$$f(x_n) = f\left(\frac{1}{n}, \frac{1}{n}\right) = \frac{\frac{1}{n^2}}{\frac{1}{n^2} + \frac{1}{n^2}} = \frac{1}{2}$$

holds for all  $n \in \mathbb{N}$ .

On the other hand, let  $\tilde{x}_n = (\frac{1}{n}, \frac{1}{n^2})$ , so that

$$f(\tilde{x}_n) = f\left(\frac{1}{n}, \frac{1}{n^2}\right) = \frac{\frac{1}{n^3}}{\frac{1}{n^2} + \frac{1}{n^4}} = \frac{1}{n^3} \frac{n^4}{n^2 + 1} = \frac{n^4}{n^5 + n^3} = \frac{\frac{1}{n}}{1 + \frac{1}{n^2}} \rightarrow 0.$$

Consequently,  $\lim_{(x,y) \rightarrow (0,0)} f(x, y)$  does not exist.

As in one variable, the limit of a function at a point can be described in alternative ways:

**Theorem 2.2.2.** *Let  $\emptyset \neq D \subset \mathbb{R}^N$ , let  $f: D \rightarrow \mathbb{R}^M$ , and let  $x_0 \in \overline{D}$ . Then the following are equivalent for  $L \in \mathbb{R}^M$ :*

- (i)  $\lim_{x \rightarrow x_0} f(x) = L$ ;
- (ii) for each  $\epsilon > 0$ , there is  $\delta > 0$  such that  $\|f(x) - L\| < \epsilon$  for each  $x \in D$  with  $\|x - x_0\| < \delta$ ;
- (iii) for each neighborhood  $U$  of  $L$ , there is a neighborhood  $V$  of  $x_0$  such that  $f^{-1}(U) = V \cap D$ .

*Proof.* (i)  $\implies$  (ii): Assume that (i) holds, but that (ii) is false. Then there is  $\epsilon_0 > 0$  such that, for each  $\delta > 0$ , there is  $x_\delta \in D$  with  $\|x_\delta - x_0\| < \delta$ , but  $\|f(x_\delta) - L\| \geq \epsilon_0$ . In particular, for each  $n \in \mathbb{N}$ , there is  $x_n \in D$  with  $\|x_n - x_0\| < \frac{1}{n}$ , but  $\|f(x_n) - L\| \geq \epsilon_0$ . It follows that  $\lim_{n \rightarrow \infty} x_n = x_0$  whereas  $f(x_n) \not\rightarrow L$ . This contradicts (i).

(ii)  $\implies$  (iii): Let  $U$  be a neighborhood of  $L$ . Choose  $\epsilon > 0$  such that  $B_\epsilon(L) \subset U$ , and choose  $\delta > 0$  as in (ii). It follows that

$$D \cap B_\delta(x_0) \subset f^{-1}(B_\epsilon(L)) \subset f^{-1}(U).$$

Let  $V := B_\delta(x_0) \cup f^{-1}(U)$ .

(iii)  $\implies$  (i): Let  $(x_n)_{n=1}^\infty$  be a sequence in  $D$  with  $\lim_{n \rightarrow \infty} x_n = x_0$ . Let  $U$  be a neighborhood of  $L$ . By (iii), there is a neighborhood  $V$  of  $x_0$  such that  $f^{-1}(U) = V \cap D$ . Since  $x_0 = \lim_{n \rightarrow \infty} x_n$ , there is  $n_V \in \mathbb{N}$  such that  $x_n \in V$  for all  $n \geq n_V$ . Consequently,  $f(x_n) \in U$  for all  $n \geq n_V$ . Since  $U$  is an arbitrary neighborhood of  $L$ , we have  $\lim_{n \rightarrow \infty} f(x_n) = L$ . Since  $(x_n)_{n=1}^\infty$  is an arbitrary sequence in  $D$  converging to  $x_0$ , (i) follows.  $\square$

**Definition 2.2.3.** Let  $\emptyset \neq D \subset \mathbb{R}^N$ , let  $f: D \rightarrow \mathbb{R}^M$ , and let  $x_0 \in D$ . Then  $f$  is *continuous at  $x_0$*  if  $\lim_{x \rightarrow x_0} f(x) = f(x_0)$ .

Applying Theorem 2.2.2 with  $L = f(x_0)$  yields:

**Theorem 2.2.4.** *Let  $\emptyset \neq D \subset \mathbb{R}^N$ , let  $f: D \rightarrow \mathbb{R}^M$ , and let  $x_0 \in D$ . Then the following are equivalent:*

- (i)  $f$  is continuous at  $x_0$ ;
- (ii) for each  $\epsilon > 0$ , there is  $\delta > 0$  such that  $\|f(x) - f(x_0)\| < \epsilon$  for each  $x \in D$  with  $\|x - x_0\| < \delta$ ;



(iii) for each neighborhood  $U$  of  $f(x_0)$ , there is a neighborhood  $V$  of  $x_0$  such that  $f^{-1}(U) = V \cap D$ .

Continuity in several variables has hereditary properties similar to those in the one variable situation:

**Proposition 2.2.5.** Let  $\emptyset \neq D \subset \mathbb{R}^N$ , and let  $f, g: D \rightarrow \mathbb{R}^M$  and  $\phi: D \rightarrow \mathbb{R}$  be continuous at  $x_0 \in D$ . Then the functions

$$\begin{aligned} f + g: D &\rightarrow \mathbb{R}^M, & x &\mapsto f(x) + g(x), \\ \phi f: D &\rightarrow \mathbb{R}^M, & x &\mapsto \phi(x)f(x), \end{aligned}$$

and

$$f \cdot g: D \rightarrow \mathbb{R}^M, \quad x \mapsto f(x) \cdot g(x)$$

are continuous at  $x_0$ .

**Proposition 2.2.6.** Let  $\emptyset \neq D_1 \subset \mathbb{R}^N$ ,  $\emptyset \neq D_2 \subset \mathbb{R}^M$ , let  $f: D_2 \rightarrow \mathbb{R}^K$  and  $g: D_1 \rightarrow \mathbb{R}^M$  be such that  $g(D_1) \subset D_2$ , and let  $x_0 \in D_1$  be such that  $g$  is continuous at  $x_0$  and that  $f$  is continuous at  $g(x_0)$ . Then

$$f \circ g: D_1 \rightarrow \mathbb{R}^K, \quad x \mapsto f(g(x))$$

is continuous at  $x_0$ .

*Proof.* Let  $(x_n)_{n=1}^{\infty}$  be a sequence in  $D$  such that  $x_n \rightarrow x_0$ . Since  $g$  is continuous at  $x_0$ , we have  $g(x_n) \rightarrow g(x_0)$ , and since  $f$  is continuous at  $g(x_0)$ , this ultimately yields  $f(g(x_n)) \rightarrow f(g(x_0))$ .  $\square$

**Proposition 2.2.7.** Let  $\emptyset \neq D \subset \mathbb{R}^N$ . Then  $f = (f_1, \dots, f_M): D \rightarrow \mathbb{R}^M$  is continuous at  $x_0 \in D$  if and only if  $f_j: D \rightarrow \mathbb{R}$  is continuous at  $x_0$  for  $j = 1, \dots, M$ .

*Examples.*

1. The function

$$f: \mathbb{R}^2 \rightarrow \mathbb{R}^3, \quad (x, y) \mapsto \left( \sin \left( \frac{xy^2}{x^2 + y^4 + \pi} \right), e^{\frac{y^{17}}{\sin(\log(\pi + \cos(x^2)))}}, 2022 \right)$$

is continuous at every point of  $\mathbb{R}^2$ .

2. Let

$$f: \mathbb{R} \rightarrow \mathbb{R}^2, \quad x \mapsto \begin{cases} (x, 1), & x \leq 0, \\ (x, -1), & x > 0, \end{cases}$$

so that

$$f_1: \mathbb{R} \rightarrow \mathbb{R}, \quad x \mapsto x$$

and

$$f_2: \mathbb{R} \rightarrow \mathbb{R}, \quad x \mapsto \begin{cases} 1, & x \leq 0, \\ -1, & x > 0. \end{cases}$$

It follows that  $f_1$  is continuous at every point of  $\mathbb{R}$ , where  $f_2$  is continuous only at  $x_0 \neq 0$ . It follows that  $f$  is continuous at every point  $x_0 \neq 0$ , but discontinuous at  $x_0 = 0$ .

### Exercises

1. Let  $D := \{(x, y) \in \mathbb{R}^2 : y \neq 0\}$ , and let

$$f: D \rightarrow \mathbb{R}, \quad (x, y) \mapsto \frac{x^2}{y}$$

Show that:

- (a)  $\lim_{\substack{t \rightarrow 0 \\ t \neq 0}} f(tx_0, ty_0) = 0$  for all  $(x_0, y_0) \in D$ ;  
 (b)  $\lim_{(x,y) \rightarrow (0,0)} f(x, y)$  does not exist.
2. Let

$$f: \mathbb{R}^3 \setminus \{0\} \rightarrow \mathbb{R}, \quad (x, y, z) \mapsto \frac{xyz}{|x|^3 + |y|^3 + |z|^3}.$$

Calculate

$$\lim_{n \rightarrow \infty} f\left(\frac{1}{n}, \frac{1}{n}, \frac{1}{n}\right) \quad \text{and} \quad \lim_{n \rightarrow \infty} f\left(\frac{1}{n}, \frac{1}{n}, \frac{1}{n^2}\right).$$

What does this tell you about  $\lim_{(x,y,z) \rightarrow (0,0,0)} f(x, y, z)$ ?

## 2.3 Global Properties of Continuous Functions

So far, we have discussed continuity only in local terms, i.e., at a point. In this section, we shall consider continuity globally.

**Definition 2.3.1.** Let  $\emptyset \neq D \subset \mathbb{R}^N$ . A function  $f: D \rightarrow \mathbb{R}^M$  is *continuous* on  $D$  if it is continuous at each point  $x_0 \in D$ .

**Theorem 2.3.2.** Let  $\emptyset \neq D \subset \mathbb{R}^N$ . Then the following are equivalent for  $f: D \rightarrow \mathbb{R}^M$ :

- (i)  $f$  is continuous.  
 (ii) for each open  $U \subset \mathbb{R}^M$ , there is an open set  $V \subset \mathbb{R}^N$  such that  $f^{-1}(U) = V \cap D$ .

*Proof.* (i)  $\implies$  (ii): Let  $U \subset \mathbb{R}^M$  be open, and let  $x \in D$  such that  $f(x) \in U$ , i.e.,  $x \in f^{-1}(U)$ . Since  $U$  is open, there is  $\epsilon_x > 0$  such that  $B_{\epsilon_x}(f(x)) \subset U$ . Since  $f$  is continuous at  $x$ , there is  $\delta_x > 0$  such that  $\|f(y) - f(x)\| < \epsilon_x$  for all  $y \in D$  with  $\|y - x\| < \delta_x$ , i.e.,

$$B_{\delta_x}(x) \cap D \subset f^{-1}(B_{\epsilon_x}(f(x))) \subset f^{-1}(U).$$

Letting  $V := \bigcup_{x \in f^{-1}(U)} B_{\delta_x}(x)$ , we obtain an open set such that

$$f^{-1}(U) \subset V \cap D \subset f^{-1}(U).$$

(ii)  $\implies$  (i): Let  $x_0 \in D$ , and choose  $\epsilon > 0$ . Then there is an open subset  $V$  of  $\mathbb{R}^N$  such that  $V \cap D = f^{-1}(B_\epsilon(f(x_0)))$ . Choose  $\delta > 0$  such that  $B_\delta(x_0) \subset V$ . It follows that  $\|f(x) - f(x_0)\| < \epsilon$  for all  $x \in D$  with  $\|x - x_0\| < \delta$ . Hence,  $f$  is continuous at  $x_0$ .  $\square$

**Corollary 2.3.3.** *Let  $\emptyset \neq D \subset \mathbb{R}^N$ . Then the following are equivalent for  $f: D \rightarrow \mathbb{R}^M$ :*

(i)  $f$  is continuous.

(ii) for each closed  $F \subset \mathbb{R}^M$ , there is a closed set  $G \subset \mathbb{R}^N$  such that  $f^{-1}(F) = G \cap D$ .

*Proof.* (i)  $\implies$  (ii): Let  $F \subset \mathbb{R}^M$  be closed. By Theorem 2.3.2, there is an open set  $V \subset \mathbb{R}^N$  such that

$$V \cap D = f^{-1}(F^c) = f^{-1}(F)^c.$$

Let  $G := V^c$ .

(ii)  $\implies$  (i): Let  $U \subset \mathbb{R}^M$  be open. By (ii), there is a closed set  $G \subset \mathbb{R}^N$  with

$$G \cap D = f^{-1}(U^c) = f^{-1}(U)^c.$$

Letting  $V := G^c$ , we obtain an open set with  $V \cap D = f^{-1}(U)$ . By Theorem 2.3.2, this implies the continuity of  $f$ .  $\square$

*Example.* The set

$$F = \{(x, y, z, u) \in \mathbb{R}^4 : e^{x+y} \sin(zu^2) \in [0, 2] \text{ and } x - y^2 + z^3 - u^4 \in [-\pi, 2022]\}$$

is closed. This can be seen as follows: The function

$$f: \mathbb{R}^4 \rightarrow \mathbb{R}^2, \quad (x, y, z, u) \mapsto (e^{x+y} \sin(zu^2), x - y^2 + z^3 - u^4)$$

is continuous,  $[0, 2] \times [-\pi, 2022]$  is closed, and  $F = f^{-1}([0, 2] \times [-\pi, 2022])$ .

**Theorem 2.3.4.** *Let  $\emptyset \neq K \subset \mathbb{R}^N$  be compact, and let  $f: K \rightarrow \mathbb{R}^M$  be continuous. Then  $f(K)$  is compact.*

*Proof.* Let  $\{U_i : i \in \mathbb{I}\}$  be an open cover for  $f(K)$ . By Theorem 2.3.2, there is, for each  $i \in \mathbb{I}$  an open subset  $V_i$  of  $\mathbb{R}^N$  such that  $V_i \cap K = f^{-1}(U_i)$ . Then  $\{V_i : i \in \mathbb{I}\}$  is an open cover for  $K$ . Since  $K$  is compact, there are  $i_1, \dots, i_n \in \mathbb{I}$  such that

$$K \subset V_{i_1} \cup \dots \cup V_{i_n}.$$

Let  $x \in K$ . Then there is  $j \in \{1, \dots, n\}$  such that  $x \in V_{i_j}$  and thus  $f(x) \in U_{i_j}$ . It follows that

$$f(K) \subset U_{i_1} \cup \dots \cup U_{i_n},$$

so that  $f(K)$  is compact. □

**Corollary 2.3.5.** *Let  $\emptyset \neq K \subset \mathbb{R}^N$  be compact, and let  $f : K \rightarrow \mathbb{R}^M$  be continuous. Then  $f(K)$  is bounded.*

**Corollary 2.3.6.** *Let  $\emptyset \neq K \subset \mathbb{R}^N$  be compact, and let  $f : K \rightarrow \mathbb{R}$  be continuous. Then there are  $x_{\max}, x_{\min} \in K$  such that*

$$f(x_{\max}) = \sup\{f(x) : x \in K\} \quad \text{and} \quad f(x_{\min}) = \inf\{f(x) : x \in K\}.$$

*Proof.* Let  $(y_n)_{n=1}^{\infty}$  be a sequence in  $f(K)$  such that  $y_n \rightarrow y_0 := \sup\{f(x) : x \in K\}$ . Since  $f(K)$  is compact and thus closed, there is  $x_{\max} \in K$  such that  $f(x_{\max}) = y_0$

The existence of  $x_{\min}$  is shown similarly. □

The two previous corollaries generalize two well known results on continuous functions on closed, bounded intervals of  $\mathbb{R}$ . They show that the crucial property of an interval, say  $[a, b]$  that makes these results work in one variable is precisely compactness.

The intermediate value theorem does not extend to continuous functions on arbitrary compact set, as can be seen by very easy examples. The crucial property of  $[a, b]$  that makes this particular theorem work is not compactness, but connectedness.

**Theorem 2.3.7.** *Let  $\emptyset \neq D \subset \mathbb{R}^N$  be connected, and let  $f : D \rightarrow \mathbb{R}^M$  be continuous. Then  $f(D)$  is connected.*

*Proof.* Assume that there is a disconnection  $\{U, V\}$  for  $f(D)$ . Since  $f$  is continuous, there are open sets  $\tilde{U}, \tilde{V} \subset \mathbb{R}^N$  open such that

$$\tilde{U} \cap D = f^{-1}(U) \quad \text{and} \quad \tilde{V} \cap D = f^{-1}(V).$$

But then  $\{\tilde{U}, \tilde{V}\}$  is a disconnection for  $D$ , which is impossible. □

This theorem can be used, for example, to show that certain sets are connected:

*Example.* The unit circle in the plane

$$S^1 := \{(x, y) \in \mathbb{R}^2 : \|(x, y)\| = 1\}$$

is connected because  $\mathbb{R}$  is connected,

$$f: \mathbb{R} \rightarrow \mathbb{R}^2, \quad t \mapsto (\cos t, \sin t)$$

is continuous, and  $S^1 = f(\mathbb{R})$ . (Inductively, one can then go on and show that  $S^{N-1}$  is connected for all  $N \geq 2$ .)

**Corollary 2.3.8** (Intermediate Value Theorem). *Let  $\emptyset \neq D \subset \mathbb{R}^N$  be connected, let  $f: D \rightarrow \mathbb{R}$  be continuous, and let  $x_1, x_2 \in D$  be such that  $f(x_1) < f(x_2)$ . Then, for each  $y \in (f(x_1), f(x_2))$ , there is  $x_y \in D$  with  $f(x_y) = y$ .*

*Proof.* Assume that there is  $y_0 \in (f(x_1), f(x_2))$  with  $y_0 \notin f(D)$ . Then  $\{U, V\}$  with

$$U := \{y \in \mathbb{R} : y < y_0\} \quad \text{and} \quad V := \{y \in \mathbb{R} : y > y_0\}$$

is a disconnection for  $f(D)$ , which contradicts Theorem 2.3.7.  $\square$

*Examples.*

1. Let  $p$  be a polynomial of odd degree with leading coefficient one, so that

$$\lim_{x \rightarrow \infty} p(x) = \infty \quad \text{and} \quad \lim_{x \rightarrow -\infty} p(x) = -\infty.$$

Hence, there are  $x_1, x_2 \in \mathbb{R}$  such that  $p(x_1) < 0 < p(x_2)$ . By the Intermediate Value Theorem, there is  $x \in \mathbb{R}$  with  $p(x) = 0$ .

2. Let

$$D := \{(x, y, z) \in \mathbb{R}^3 : \|(x, y, z)\| \leq \pi\},$$

so that  $D$  is connected. Let

$$f: D \rightarrow \mathbb{R}, \quad (x, y, z) \mapsto \frac{xy + z}{\cos(xyz)^2 + 1}.$$

Then

$$f(0, 0, 0) = 0 \quad \text{and} \quad f(1, 0, 1) = \frac{1}{1+1} = \frac{1}{2}.$$

Hence, there is  $(x_0, y_0, z_0) \in D$  such that  $f(x_0, y_0, z_0) = \frac{1}{\pi}$ .

**Exercises**

1. Let  $K, L \subset \mathbb{R}^N$  be compact. Show that

$$K + L := \{x + y : x \in K, y \in L\}$$

is compact in  $\mathbb{R}^N$ .

2. Show that, if  $C_1, C_2 \subset \mathbb{R}^N$  are connected, then so is  $C_1 + C_2 \subset \mathbb{R}^N$ .
3. Let  $C \subset \mathbb{R}^N$ . We say that  $x_0, x_1 \in C$  can be *joined by a path* if there is a continuous function  $\gamma: [0, 1] \rightarrow \mathbb{R}^N$  with  $\gamma([0, 1]) \subset C$ ,  $\gamma(0) = x_0$ , and  $\gamma(1) = x_1$ . We call  $C$  *path connected* if any two points in  $C$  can be joined by a path.

Show that any path connected set is connected.

4. Show that:

- (a) if  $C_1 \subset \mathbb{R}^{N_1}$  and  $C_2 \subset \mathbb{R}^{N_2}$  are path connected, then so is  $C_1 \times C_2 \subset \mathbb{R}^{N_1+N_2}$ ;
- (b) if  $C \subset \mathbb{R}^N$  is path connected and  $f: C \rightarrow \mathbb{R}^M$  is continuous, then  $f(C)$  is path connected;
- (c) if  $C_1, C_2 \subset \mathbb{R}^N$  is path connected, then so is  $C_1 + C_2 \subset \mathbb{R}^N$ .

5. Let

$$C := \left\{ \left( x, \sin \left( \frac{1}{x} \right) \right) : x > 0 \right\} \subset \mathbb{R}^2.$$

Show that  $\overline{C}$  is connected, but not path connected. (*Hint*: Show that  $\{0\} \times [-1, 1] \subset \overline{C}$  and that any point in  $\{0\} \times [-1, 1]$  cannot be joined by a path with any point of the form  $(x, \sin(\frac{1}{x}))$  with  $x > 0$ .)

6. Show that  $\mathbb{R}^N \setminus \{0\}$  is disconnected if and only if  $N = 1$ .

7. Let

$$D := \{(e^{xy}, e^{-x^2-z}) : (x, y, z) \in \mathbb{R}^3\}$$

Short that there is  $(u, v) \in D$  such that

$$\log(u + v) = \sqrt{19}.$$

8. Let  $\emptyset \neq D \subset \mathbb{R}^N$ . A point  $x_0 \in D$  is called an *isolated point* of  $D$  if there is  $\epsilon > 0$  such that  $B_\epsilon(x_0) \cap D = \{x_0\}$ . Show that the following are equivalent for  $x_0 \in D$ :

- (i)  $x_0$  is an isolated point of  $D$ ;
- (ii)  $x_0$  is not a cluster point of  $D$ ;

- (iii) every sequence  $(x_n)_{n=1}^{\infty}$  in  $D$  such that  $\lim_{n \rightarrow \infty} x_n = x_0$  is eventually constant, i.e., there is  $n_0 \in \mathbb{N}$  such that  $x_n = x_0$  for all  $n \geq n_0$ ;
  - (iv) every function  $f: D \rightarrow \mathbb{R}$  is continuous at  $x_0$ .
9. A set  $D \subset \mathbb{R}^N$  is called *discrete* if each  $x \in D$  is an isolated point of  $D$ . Show that:
- (a)  $\mathbb{Z}$  and  $\{\frac{1}{n} : n \in \mathbb{N}\}$  are discrete;
  - (b)  $\mathbb{Q}$  is not discrete;
  - (c) a compact set is discrete if and only if it is finite.

## 2.4 Uniform Continuity

We conclude the chapter on continuity, with a property related to, but stronger than continuity:

**Definition 2.4.1.** Let  $\emptyset \neq D \subset \mathbb{R}^N$ . Then  $f: D \rightarrow \mathbb{R}^M$  is called *uniformly continuous* if, for each  $\epsilon > 0$ , there is  $\delta > 0$  such that  $\|f(x_1) - f(x_2)\| < \epsilon$  for all  $x_1, x_2 \in D$  with  $\|x_1 - x_2\| < \delta$ .

The difference between uniform continuity and continuity at every point is that the  $\delta > 0$  in the definition of uniform continuity depends only on  $\epsilon > 0$ , but not on a particular point of the domain.

*Examples.*

1. All constant functions are uniformly continuous.
2. The function

$$f: [0, 1] \rightarrow \mathbb{R}, \quad x \mapsto x^2$$

is uniformly continuous. To see this, let  $\epsilon > 0$ , and observe that

$$|x_1^2 - x_2^2| = |x_1 - x_2|(x_1 + x_2) \leq 2|x_1 - x_2|$$

for all  $x_1, x_2 \in [0, 1]$ . Choose  $\delta := \frac{\epsilon}{2}$ .

3. The function

$$f: (0, 1] \rightarrow \mathbb{R}, \quad x \mapsto \frac{1}{x}$$

is continuous, but not uniformly continuous. For each  $n \in \mathbb{N}$ , we have

$$\left| f\left(\frac{1}{n}\right) - f\left(\frac{1}{n+1}\right) \right| = |n - (n+1)| = 1.$$

Therefore, there is *no*  $\delta > 0$  such that  $\left| f\left(\frac{1}{n}\right) - f\left(\frac{1}{n+1}\right) \right| < \frac{1}{2}$  whenever  $\left| \frac{1}{n} - \frac{1}{n+1} \right| < \delta$ .

4. The function

$$f: [0, \infty) \rightarrow \mathbb{R}, \quad x \mapsto x^2$$

is continuous, but not uniformly continuous. Assume that there is  $\delta > 0$  such that  $|f(x_1) - f(x_2)| < 1$  for all  $x_1, x_2 \geq 0$  with  $|x_1 - x_2| < \delta$ . Choose,  $x_1 := \frac{2}{\delta}$  and  $x_2 := \frac{2}{\delta} + \frac{\delta}{2}$ . It follows that  $|x_1 - x_2| = \frac{\delta}{2} < \delta$ . However, we have

$$\begin{aligned} |f(x_1) - f(x_2)| &= |x_1 - x_2|(x_1 + x_2) \\ &= \frac{\delta}{2} \left( \frac{2}{\delta} + \frac{2}{\delta} + \frac{\delta}{2} \right) \\ &\geq \frac{\delta}{2} \cdot 4 \\ &= 2. \end{aligned}$$

The following theorem is very valuable when it comes to determining that a given function is uniformly continuous:

**Theorem 2.4.2.** *Let  $\emptyset \neq K \subset \mathbb{R}^N$  be compact, and let  $f: K \rightarrow \mathbb{R}^M$  be continuous. Then  $f$  is uniformly continuous.*

*Proof.* Assume that  $f$  is not uniformly continuous, i.e., there is  $\epsilon_0 > 0$  such that, for all  $\delta > 0$ , there are  $x_\delta, y_\delta \in K$  with  $\|x_\delta - y_\delta\| < \delta$  whereas  $\|f(x_\delta) - f(y_\delta)\| \geq \epsilon_0$ . In particular, there are, for each  $n \in \mathbb{N}$ , elements  $x_n, y_n \in K$  such that

$$\|x_n - y_n\| < \frac{1}{n} \quad \text{and} \quad \|f(x_n) - f(y_n)\| \geq \epsilon_0.$$

Since  $K$  is compact,  $(x_n)_{n=1}^\infty$  has a subsequence  $(x_{n_k})_{k=1}^\infty$  converging to some  $x \in K$ . Since  $x_{n_k} - y_{n_k} \rightarrow 0$ , it follows that

$$x = \lim_{k \rightarrow \infty} x_{n_k} = \lim_{k \rightarrow \infty} y_{n_k}.$$

The continuity of  $f$  yields

$$f(x) = \lim_{k \rightarrow \infty} f(x_{n_k}) = \lim_{k \rightarrow \infty} f(y_{n_k}).$$

Hence, there are  $k_1, k_2 \in \mathbb{N}$  such that

$$\|f(x) - f(x_{n_k})\| < \frac{\epsilon_0}{2} \quad \text{for } k \geq k_1 \quad \text{and} \quad \|f(x) - f(y_{n_k})\| < \frac{\epsilon_0}{2} \quad \text{for } k \geq k_2.$$

For  $k \geq \max\{k_1, k_2\}$ , we thus have

$$\|f(x_{n_k}) - f(y_{n_k})\| \leq \|f(x_{n_k}) - f(x)\| + \|f(x) - f(y_{n_k})\| < \frac{\epsilon_0}{2} + \frac{\epsilon_0}{2} = \epsilon_0,$$

which is a contradiction. □



**Exercises**

1. Let  $\emptyset \neq D \subset \mathbb{R}^N$ . A function  $f: D \rightarrow \mathbb{R}^M$  is called *Lipschitz continuous* if there is  $C \geq 0$  such that

$$\|f(x) - f(y)\| \leq C\|x - y\|$$

for all  $x, y \in D$ .

Show that:

- (a) each Lipschitz continuous function is uniformly continuous;
- (b) if  $f: [a, b] \rightarrow \mathbb{R}$  is continuous such that  $f$  is differentiable on  $(a, b)$  with  $f'$  bounded on  $(a, b)$ , then  $f$  is Lipschitz continuous;
- (c) the function

$$f: [0, 1] \rightarrow \mathbb{R}, \quad x \mapsto \sqrt{x}$$

is uniformly continuous, but not Lipschitz continuous.

2. (*Banach's Fixed Point Theorem.*) Let  $\emptyset \neq F \subset \mathbb{R}^N$  be closed, and let  $f: F \rightarrow \mathbb{R}^N$  be such that  $f(F) \subset F$  and that there is  $\theta \in (0, 1)$  with

$$\|f(x) - f(y)\| \leq \theta\|x - y\|$$

for  $x, y \in F$ . Show that there is a unique  $x_0 \in F$  such that  $f(x_0) = x_0$ . (*Hint: Problem 2.1.3.*)

3. Let  $\emptyset \neq D \subset \mathbb{R}^N$ , let  $f: D \rightarrow \mathbb{R}^M$  be continuous, and let  $(x_n)_{n=1}^{\infty}$  be a Cauchy sequence in  $D$ . Show that  $(f(x_n))_{n=1}^{\infty}$  is a Cauchy sequence in  $\mathbb{R}^M$  if  $D$  is closed or if  $f$  is uniformly continuous.

Does this remain true without any additional requirements for  $D$  or  $f$ ?

# Chapter 3

## Differentiation in $\mathbb{R}^N$

### 3.1 Differentiation in One Variable: A Review

In this section, we give a quick review of differentiation in one variable.

**Definition 3.1.1.** Let  $I \subset \mathbb{R}$  be an interval, and let  $x_0 \in I$ . Then  $f: I \rightarrow \mathbb{R}$  is said to be *differentiable at  $x_0$*  if

$$\lim_{\substack{h \rightarrow 0 \\ h \neq 0}} \frac{f(x_0 + h) - f(x_0)}{h}$$

exists. This limit is denoted by  $f'(x_0)$  or  $\frac{df}{dx}(x_0)$  and called the *first derivative* of  $f$  at  $x_0$ .

Intuitively, differentiability of  $f$  at  $x_0$  means that we can put a tangent line to the curve given by  $f$  at  $(x_0, f(x_0))$  of which the slope is  $f'(x_0)$ :

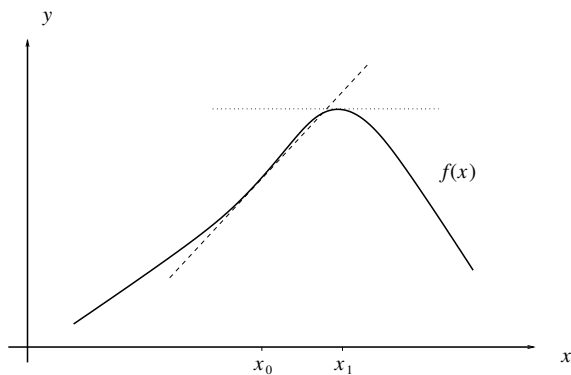

Figure 3.1: Tangent lines to  $f(x)$  at  $x_0$  and  $x_1$

*Example.* Let  $n \in \mathbb{N}$ , and let

$$f: \mathbb{R} \rightarrow \mathbb{R}, \quad x \mapsto x^n.$$

Let  $h \in \mathbb{R} \setminus \{0\}$ . From the Binomial Theorem, we know that

$$(x+h)^n = \sum_{j=0}^n \binom{n}{j} x^j h^{n-j}$$

and thus

$$(x+h)^n - x^n = \sum_{j=0}^{n-1} \binom{n}{j} x^j h^{n-j}.$$

Letting  $h \rightarrow 0$ , we obtain

$$\begin{aligned} \frac{(x+h)^n - x^n}{h} &= \sum_{j=0}^{n-1} \binom{n}{j} x^j h^{n-j-1} \\ &= \sum_{j=0}^{n-2} \binom{n}{j} x^j h^{\overbrace{n-j-1}^{>0}} + nx^{n-1} \\ &\rightarrow nx^{n-1}. \end{aligned}$$

**Proposition 3.1.2.** *Let  $I \subset \mathbb{R}$  be an interval, and let  $f : I \rightarrow \mathbb{R}$  be differentiable at  $x_0 \in I$ . Then  $f$  is continuous at  $x_0$ .*

*Proof.* Let  $(x_n)_{n=1}^\infty$  be a sequence in  $I$  such that  $x_n \rightarrow x_0$ . Without loss of generality, suppose that  $x_n \neq x_0$  for all  $n \in \mathbb{N}$ . It follows that

$$|f(x_n) - f(x_0)| = \underbrace{|x_n - x_0|}_{\rightarrow 0} \underbrace{\left| \frac{f(x_n) - f(x_0)}{x_n - x_0} \right|}_{\rightarrow |f'(x_0)|} \rightarrow 0.$$

Hence,  $f$  is continuous at  $x_0$ . □

We recall the differentiation rules without proof:

**Proposition 3.1.3** (Rules of Differentiation). *Let  $I \subset \mathbb{R}$  be an interval, and let  $f, g : I \rightarrow \mathbb{R}$  be differentiable at  $x_0 \in I$ . Then  $f + g$ ,  $fg$ , and—if  $g(x_0) \neq 0$ ,  $\frac{f}{g}$ —are differentiable at  $x_0$  such that*

$$\begin{aligned} (f+g)'(x_0) &= f'(x_0) + g'(x_0), \\ (fg)'(x_0) &= f(x_0)g'(x_0) + f'(x_0)g(x_0), \end{aligned}$$

and

$$\left(\frac{f}{g}\right)'(x_0) = \frac{f'(x_0)g(x_0) - f(x_0)g'(x_0)}{g(x_0)^2}.$$

**Proposition 3.1.4** (Chain Rule). *Let  $I, J \subset \mathbb{R}$  be intervals, let  $g: I \rightarrow \mathbb{R}$  and  $f: J \rightarrow \mathbb{R}$  be functions such that  $g(I) \subset J$ , and suppose that  $g$  is differentiable at  $x_0 \in I$  and that  $f$  is differentiable at  $g(x_0) \in J$ . Then  $f \circ g: I \rightarrow \mathbb{R}$  is differentiable at  $x_0$  such that*

$$(f \circ g)'(x_0) = f'(g(x_0))g'(x_0).$$

**Definition 3.1.5.** Let  $I \subset \mathbb{R}$  be an interval. We call  $f: I \rightarrow \mathbb{R}$  *differentiable* if it is differentiable at each point of  $I$ .

*Example.* Define

$$f: \mathbb{R} \rightarrow \mathbb{R}, \quad x \mapsto \begin{cases} x^2 \sin\left(\frac{1}{x}\right), & x \neq 0, \\ 0, & x = 0. \end{cases}$$

It is clear  $f$  is differentiable at all  $x \neq 0$  with

$$\begin{aligned} f'(x) &= 2x \sin\left(\frac{1}{x}\right) - x^2 \frac{1}{x^2} \cos\left(\frac{1}{x}\right) \\ &= 2x \sin\left(\frac{1}{x}\right) - \cos\left(\frac{1}{x}\right). \end{aligned}$$

Let  $h \neq 0$ . Then we have

$$\left| \frac{f(0+h) - f(0)}{h} \right| = \left| \frac{1}{h} h^2 \sin\left(\frac{1}{h}\right) \right| = \left| h \sin\left(\frac{1}{h}\right) \right| \leq |h| \xrightarrow{h \rightarrow 0} 0,$$

so that  $f$  is also differentiable at  $x = 0$  with  $f'(0) = 0$ . Let  $x_n := \frac{1}{2\pi n}$ , so that  $x_n \rightarrow 0$ . It follows that

$$f'(x_n) = \underbrace{\frac{1}{\pi n} \sin(2\pi n)}_{=0} - \underbrace{\cos(2\pi n)}_{=1} \not\rightarrow f'(0).$$

Hence,  $f'$  is not continuous at  $x = 0$ .

**Definition 3.1.6.** Let  $\emptyset \neq D \subset \mathbb{R}$ , and let  $x_0$  be an interior point of  $D$ . Then  $f: D \rightarrow \mathbb{R}$  is said to have a *local maximum* [*minimum*] at  $x_0$  if there is  $\epsilon > 0$  such that  $(x_0 - \epsilon, x_0 + \epsilon) \subset D$  and  $f(x) \leq f(x_0)$  [ $f(x) \geq f(x_0)$ ] for all  $x \in (x_0 - \epsilon, x_0 + \epsilon)$ . If  $f$  has a local maximum or minimum at  $x_0$ , we say that  $f$  has a *local extremum* at  $x_0$ .

**Theorem 3.1.7.** *Let  $\emptyset \neq D \subset \mathbb{R}$ , let  $f: D \rightarrow \mathbb{R}$  have a local extremum at  $x_0 \in \text{int } D$ , and suppose that  $f$  is differentiable at  $x_0$ . Then  $f'(x_0) = 0$  holds.*

*Proof.* We only treat the case of a local maximum.

Let  $\epsilon > 0$  be as in Definition 3.1.6. For  $h \in (-\epsilon, 0)$ , we have  $x_0 + h \in (x_0 - \epsilon, x_0 + \epsilon)$ , so that

$$\frac{\overbrace{f(x_0 + h) - f(x_0)}^{\leq 0}}{\underbrace{h}_{\leq 0}} \geq 0.$$

It follows that  $f'(x_0) \geq 0$ . On the other hand, we have for  $h \in (0, \epsilon)$  that

$$\frac{\overbrace{f(x_0 + h) - f(x_0)}^{\leq 0}}{\underbrace{h}_{\geq 0}} \leq 0,$$

so that  $f'(x_0) \leq 0$ .

Consequently,  $f'(x_0) = 0$  holds.  $\square$

**Lemma 3.1.8** (Rolle's "Theorem"). *Let  $a < b$ , and let  $f: [a, b] \rightarrow \mathbb{R}$  be continuous such that  $f(a) = f(b)$  and such that  $f$  is differentiable on  $(a, b)$ . Then there is  $\xi \in (a, b)$  such that  $f'(\xi) = 0$ .*

*Proof.* The claim is clear if  $f$  is constant. Hence, we may suppose that  $f$  is not constant.

Since  $f$  is continuous, there is  $\xi_1, \xi_2 \in [a, b]$  such that

$$f(\xi_1) = \sup\{f(x) : x \in [a, b]\} \quad \text{and} \quad f(\xi_2) = \inf\{f(x) : x \in [a, b]\}.$$

Since  $f$  is not constant and since  $f(a) = f(b)$ , it follows that  $f$  attains at least one local extremum at some point  $\xi \in (a, b)$ . By Theorem 3.1.7, this means  $f'(\xi) = 0$ .  $\square$

**Theorem 3.1.9** (Mean Value Theorem). *Let  $a < b$ , and let  $f: [a, b] \rightarrow \mathbb{R}$  be continuous and differentiable on  $(a, b)$ . Then there is  $\xi \in (a, b)$  such that*

$$f'(\xi) = \frac{f(b) - f(a)}{b - a}.$$

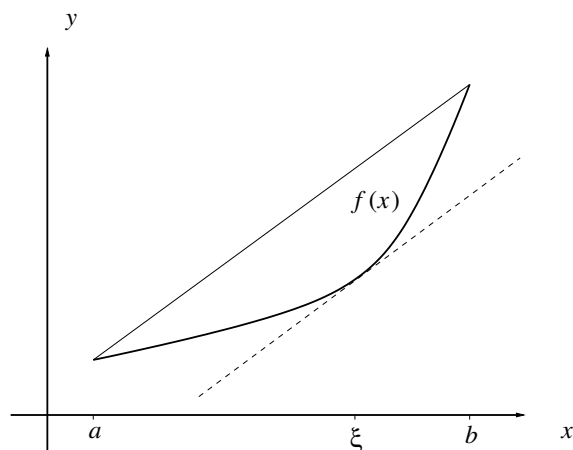

Figure 3.2: Mean Value Theorem

*Proof.* Define  $g: [a, b] \rightarrow \mathbb{R}$  by letting

$$g(x) := (f(x) - f(a))(b - a) - (f(b) - f(a))(x - a)$$

for  $x \in [a, b]$ . It follows that  $g(a) = g(b) = 0$ . By Rolle's theorem, there is  $\xi \in (a, b)$  such that

$$0 = g'(\xi) = f'(\xi)(b - a) - (f(b) - f(a)),$$

which yields the claim.  $\square$

**Corollary 3.1.10.** *Let  $I \subset \mathbb{R}$  be an interval, and let  $f: I \rightarrow \mathbb{R}$  be differentiable such that  $f' \equiv 0$ . Then  $f$  is constant.*

*Proof.* Assume that  $f$  is not constant. Then there are  $a, b \in I$ ,  $a < b$  such that  $f(a) \neq f(b)$ . By the mean value theorem, there is  $\xi \in (a, b)$  such that

$$0 = f'(\xi) = \frac{f(b) - f(a)}{b - a} \neq 0,$$

which is a contradiction.  $\square$

## 3.2 Partial Derivatives

The notion of partial differentiability is the weakest of the several generalizations of differentiability to several variables.

**Definition 3.2.1.** Let  $\emptyset \neq D \subset \mathbb{R}^N$ , and let  $x_0 \in \text{int } D$ . Then  $f: D \rightarrow \mathbb{R}^M$  is called *partially differentiable* at  $x_0$  if, for each  $j = 1, \dots, N$ , the limit

$$\lim_{\substack{h \rightarrow 0 \\ h \neq 0}} \frac{f(x_0 + h\mathbf{e}_j) - f(x_0)}{h}$$

exists, where  $\mathbf{e}_j$  is the  $j$ -th canonical basis vector of  $\mathbb{R}^N$ .

We use the notations

$$\left. \begin{array}{l} \frac{\partial f}{\partial x_j}(x_0) \\ D_j f(x_0) \\ f_{x_j}(x_0) \end{array} \right\} := \lim_{\substack{h \rightarrow 0 \\ h \neq 0}} \frac{f(x_0 + h\mathbf{e}_j) - f(x_0)}{h}$$

for the (first) partial derivative of  $f$  at  $x_0$  with respect to  $x_j$ .

To calculate  $\frac{\partial f}{\partial x_j}$ , fix  $x_1, \dots, x_{j-1}, x_{j+1}, \dots, x_N$ , i.e., treat them as constants, and consider  $f$  as a function of  $x_j$ .

*Examples.*

1. Let

$$f: \mathbb{R}^2 \rightarrow \mathbb{R}, \quad (x, y) \mapsto e^x + x \cos(xy).$$

It follows that

$$\frac{\partial f}{\partial x}(x, y) = e^x + \cos(xy) - xy \sin(xy) \quad \text{and} \quad \frac{\partial f}{\partial y}(x, y) = -x^2 \sin(xy).$$

2. Let

$$f: \mathbb{R}^3 \rightarrow \mathbb{R}, \quad (x, y, z) \mapsto \exp(x \sin(y)z^2).$$

We obtain

$$\frac{\partial f}{\partial x}(x, y, z) = \sin(y)z^2 \exp(x \sin(y)z^2), \quad \frac{\partial f}{\partial y}(x, y, z) = x \cos(y)z^2 \exp(x \sin(y)z^2),$$

and

$$\frac{\partial f}{\partial z}(x, y, z) = 2zx \sin(y) \exp(x \sin(y)z^2).$$

3. Let

$$f: \mathbb{R}^2 \rightarrow \mathbb{R}, \quad (x, y) \mapsto \begin{cases} \frac{xy}{x^2+y^2}, & (x, y) \neq (0, 0), \\ 0, & (x, y) = (0, 0). \end{cases}$$

Since

$$f\left(\frac{1}{n}, \frac{1}{n}\right) = \frac{\frac{1}{n^2}}{\frac{1}{n^2} + \frac{1}{n^2}} = \frac{1}{2} \not\rightarrow 0,$$

the function  $f$  is not continuous at  $(0, 0)$ . Clearly,  $f$  is partially differentiable at each  $(x, y) \neq (0, 0)$  with

$$\frac{\partial f}{\partial x}(x, y) = \frac{y(x^2 + y^2) - 2x^2y}{(x^2 + y^2)^2}.$$

Moreover, we have

$$\frac{\partial f}{\partial x}(0, 0) = \lim_{\substack{h \rightarrow 0 \\ h \neq 0}} \frac{f(h, 0) - f(0, 0)}{h} = 0.$$

Hence,  $\frac{\partial f}{\partial x}$  exists everywhere.

The same is true for  $\frac{\partial f}{\partial y}$ .

**Definition 3.2.2.** Let  $\emptyset \neq D \subset \mathbb{R}^N$ , let  $x_0 \in \text{int } D$ , and let  $f: D \rightarrow \mathbb{R}$  be partially differentiable at  $x_0$ . Then the *gradient (vector)* of  $f$  at  $x_0$  is defined as

$$(\text{grad } f)(x_0) := (\nabla f)(x_0) := \left( \frac{\partial f}{\partial x_1}(x_0), \dots, \frac{\partial f}{\partial x_N}(x_0) \right).$$

*Example.* Let

$$f: \mathbb{R}^N \rightarrow \mathbb{R}, \quad x \mapsto \|x\| = \sqrt{x_1^2 + \cdots + x_N^2},$$

so that, for  $x \neq 0$  and  $j = 1, \dots, N$ ,

$$\frac{\partial f}{\partial x_j}(x) = \frac{2x_j}{2\sqrt{x_1^2 + \cdots + x_N^2}} = \frac{x_j}{\|x\|}$$

holds. Hence, we have  $(\text{grad } f)(x) = \frac{x}{\|x\|}$  for  $x \neq 0$ .

**Definition 3.2.3.** Let  $\emptyset \neq D \subset \mathbb{R}^N$ , and let  $x_0$  be an interior point of  $D$ . Then  $f: D \rightarrow \mathbb{R}$  is said to have a *local maximum* [*minimum*] at  $x_0$  if there is  $\epsilon > 0$  such that  $B_\epsilon(x_0) \subset D$  and  $f(x) \leq f(x_0)$  [ $f(x) \geq f(x_0)$ ] for all  $x \in B_\epsilon(x_0)$ . If  $f$  has a local maximum or minimum at  $x_0$ , we say that  $f$  has a *local extremum* at  $x_0$ .

**Theorem 3.2.4.** Let  $\emptyset \neq D \subset \mathbb{R}^N$ , let  $x_0 \in \text{int } D$ , and let  $f: D \rightarrow \mathbb{R}$  be partially differentiable and have local extremum at  $x_0$ . Then  $(\text{grad } f)(x_0) = 0$  holds.

*Proof.* Suppose without loss of generality that  $f$  has a local maximum at  $x_0$ .

Fix  $j \in \{1, \dots, N\}$ . Let  $\epsilon > 0$  be as in Definition 3.2.3, and define

$$g: (-\epsilon, \epsilon) \rightarrow \mathbb{R}, \quad t \mapsto f(x_0 + te_j).$$

It follows that, for all  $t \in (-\epsilon, \epsilon)$ , the inequality

$$g(t) = f(\underbrace{x_0 + te_j}_{\in B_\epsilon(x_0)}) \leq f(x_0) = g(0)$$

holds, i.e.,  $g$  has a local maximum at 0. By Theorem 3.1.7, this means that

$$\frac{\partial f}{\partial x_j}(x_0) = \lim_{\substack{h \rightarrow 0 \\ h \neq 0}} \frac{f(x_0 + he_j) - f(x_0)}{h} = \lim_{\substack{h \rightarrow 0 \\ h \neq 0}} \frac{g(h) - g(0)}{h} = g'(0) = 0.$$

Since  $j \in \{1, \dots, N\}$  was arbitrary, this completes the proof.  $\square$

Let  $\emptyset \neq U \subset \mathbb{R}^N$  be open, and let  $f: U \rightarrow \mathbb{R}$  be partially differentiable, i.e., partially differentiable at each point of  $U$ , and let  $j \in \{1, \dots, N\}$  be such that  $\frac{\partial f}{\partial x_j}: U \rightarrow \mathbb{R}$  is again partially differentiable. One can then form the *second partial derivatives*

$$\frac{\partial^2 f}{\partial x_k \partial x_j} := \frac{\partial}{\partial x_k} \left( \frac{\partial f}{\partial x_j} \right)$$

for  $k = 1, \dots, N$ . Of course, one can continue in this fashion and define partial derivatives arbitrarily high order.



*Example.* Let  $U := \{(x, y) \in \mathbb{R}^2 : x \neq 0\}$ , and define

$$f: U \rightarrow \mathbb{R}, \quad (x, y) \mapsto \frac{e^{xy}}{x}.$$

It follows that

$$\begin{aligned} \frac{\partial f}{\partial x} &= \frac{xye^{xy} - e^{xy}}{x^2} \\ &= \frac{xy - 1}{x^2} e^{xy} \\ &= \left( \frac{y}{x} - \frac{1}{x^2} \right) e^{xy}, \end{aligned}$$

and

$$\frac{\partial f}{\partial y} = e^{xy}.$$

For the second partial derivatives, this means that

$$\begin{aligned} \frac{\partial^2 f}{\partial x^2} &= \left( -\frac{y}{x^2} + \frac{2}{x^3} \right) e^{xy} + \left( \frac{y}{x} - \frac{1}{x^2} \right) ye^{xy}, \\ \frac{\partial^2 f}{\partial y^2} &= xe^{xy}, \\ \frac{\partial^2 f}{\partial x \partial y} &= ye^{xy}, \end{aligned}$$

and

$$\frac{\partial^2 f}{\partial y \partial x} = \frac{1}{x} e^{xy} + \left( \frac{y}{x} - \frac{1}{x^2} \right) xe^{xy} = \frac{1}{x} e^{xy} + \left( y - \frac{1}{x} \right) e^{xy} = ye^{xy}.$$

This means that

$$\frac{\partial^2 f}{\partial x \partial y} = \frac{\partial^2 f}{\partial y \partial x}.$$

holds. Is this coincidence?

Let  $\emptyset \neq U \subset \mathbb{R}^N$  be open, let  $f: U \rightarrow \mathbb{R}$  be partially differentiable such that  $\frac{\partial f}{\partial x_j}: U \rightarrow \mathbb{R}$  is continuous for  $j = 1, \dots, N$ . Then we call  $f$  *continuously partially differentiable*.

**Theorem 3.2.5** (Clairaut's Theorem). *Let  $\emptyset \neq U \subset \mathbb{R}^N$  be open, and suppose that  $f: U \rightarrow \mathbb{R}$  is twice continuously partially differentiable, i.e., all second partial derivatives of  $f$  exist and are continuous on  $U$ . Then*

$$\frac{\partial^2 f}{\partial x_j \partial x_k}(x) = \frac{\partial^2 f}{\partial x_k \partial x_j}(x)$$

*holds for all  $x \in U$  and for all  $j, k = 1, \dots, N$ .*

*Proof.* Without loss of generality, let  $N = 2$  and  $x = 0$ .

Since  $U$  is open, there is  $\epsilon > 0$  such that  $(-\epsilon, \epsilon)^2 \subset U$ . Fix  $y \in (-\epsilon, \epsilon)$ , and define

$$F_y: (-\epsilon, \epsilon) \rightarrow \mathbb{R}, \quad x \mapsto f(x, y) - f(x, 0).$$

Then  $F_y$  is differentiable. By the Mean Value Theorem, there is, for each  $x \in (-\epsilon, \epsilon)$ , an element  $\xi \in (-\epsilon, \epsilon)$  with  $|\xi| \leq |x|$  such that

$$F_y(x) - F_y(0) = F'_y(\xi)x = \left( \frac{\partial f}{\partial x}(\xi, y) - \frac{\partial f}{\partial x}(\xi, 0) \right) x.$$

Applying the Mean Value Theorem to the function

$$(-\epsilon, \epsilon) \rightarrow \mathbb{R}, \quad y \mapsto \frac{\partial f}{\partial x}(\xi, y),$$

we obtain  $\eta$  with  $|\eta| \leq |y|$  such that

$$\frac{\partial f}{\partial x}(\xi, y) - \frac{\partial f}{\partial x}(\xi, 0) = \frac{\partial^2 f}{\partial y \partial x}(\xi, \eta)y.$$

Consequently,

$$f(x, y) - f(x, 0) - f(0, y) + f(0, 0) = F_y(x) - F_y(0) = \frac{\partial^2 f}{\partial y \partial x}(\xi, \eta)xy$$

holds.

Now, fix  $x \in (-\epsilon, \epsilon)$ , and define

$$\tilde{F}_x: (-\epsilon, \epsilon) \rightarrow \mathbb{R}, \quad y \mapsto f(x, y) - f(0, y).$$

Proceeding as with  $F_y$ , we obtain  $\tilde{\xi}, \tilde{\eta}$  with  $|\tilde{\xi}| \leq |x|$  and  $|\tilde{\eta}| \leq |y|$  such that

$$f(x, y) - f(0, y) - f(x, 0) + f(0, 0) = \frac{\partial^2 f}{\partial x \partial y}(\tilde{\xi}, \tilde{\eta})xy.$$

Therefore,

$$\frac{\partial^2 f}{\partial y \partial x}(\xi, \eta) = \frac{\partial^2 f}{\partial x \partial y}(\tilde{\xi}, \tilde{\eta})$$

holds whenever  $xy \neq 0$ . Let  $0 \neq x \rightarrow 0$  and  $0 \neq y \rightarrow 0$ . It follows that  $\xi \rightarrow 0$ ,  $\tilde{\xi} \rightarrow 0$ ,  $\eta \rightarrow 0$ , and  $\tilde{\eta} \rightarrow 0$ . Since  $\frac{\partial^2 f}{\partial y \partial x}$  and  $\frac{\partial^2 f}{\partial x \partial y}$  are continuous, this yields

$$\frac{\partial^2 f}{\partial y \partial x}(0, 0) = \frac{\partial^2 f}{\partial x \partial y}(0, 0)$$

as claimed. □

The usefulness of Clairaut's Theorem appears to be limited: in order to be able to interchange the order of differentiation, we first need to know that the second order partial derivatives are continuous, i.e., we need to know the second order partial derivatives before the theorem can help us save any work computing them. For many functions, however, e.g., for

$$f: \mathbb{R}^3 \rightarrow \mathbb{R}, \quad (x, y, z) \mapsto \frac{\arctan(x^2 - y^7)}{e^{xyz}},$$

it is immediate from the rules of differentiation that their higher order partial derivatives are continuous again *without explicitly computing them*.

### Exercises

1. Show that the mean value theorem becomes false for vector valued functions: Let

$$f: [0, 2\pi] \rightarrow \mathbb{R}^2, \quad x \mapsto (\cos(x), \sin(x)).$$

Show that there is *no*  $\xi \in (0, 2\pi)$  such that

$$f'(\xi) = \frac{f(2\pi) - f(0)}{2\pi}.$$

2. Let

$$f: \mathbb{R}^2 \rightarrow \mathbb{R}, \quad (x, y) \mapsto \begin{cases} xy \frac{x^2 - y^2}{x^2 + y^2}, & \text{if } (x, y) \neq (0, 0), \\ 0, & \text{otherwise.} \end{cases}$$

Show that  $f$  is twice partially differentiable everywhere, but that

$$\frac{\partial^2 f}{\partial y \partial x}(0, 0) \neq \frac{\partial^2 f}{\partial x \partial y}(0, 0).$$

Is  $f$  continuous at  $(0, 0)$ ?

3. Calculate all partial derivatives up to order two of the functions

$$f(x, y) := x^2 - 42xy^3 - yx \quad \text{and} \quad f(x, y, z) := \frac{xe^y}{z}$$

where  $z \neq 0$  for the latter function.

## 3.3 Vector Fields

Suppose that there is a force field in some region of space. Mathematically, a force is a vector in  $\mathbb{R}^3$ . Hence, one can mathematically describe a force field as a function  $v$  that that assigns to each point  $x$  in a region, say  $D$ , of  $\mathbb{R}^3$  a force  $v(x)$ .

Slightly generalizing this, we thus define:

**Definition 3.3.1.** Let  $\emptyset \neq D \subset \mathbb{R}^N$ . A *vector field* on  $D$  is a function  $v: D \rightarrow \mathbb{R}^N$ .

*Example.* Let  $\emptyset \neq U \subset \mathbb{R}^N$  be open, and let  $f: U \rightarrow \mathbb{R}$  be partially differentiable. Then  $\nabla f$  is a vector field on  $U$ , a so-called *gradient field*.

Is every vector field a gradient field?

**Definition 3.3.2.** Let  $\emptyset \neq U \subset \mathbb{R}^3$  be open, and let  $v: U \rightarrow \mathbb{R}^3$  be partially differentiable. Then the *curl* of  $v$  is defined as

$$\operatorname{curl} v := \left( \frac{\partial v_3}{\partial x_2} - \frac{\partial v_2}{\partial x_3}, \frac{\partial v_1}{\partial x_3} - \frac{\partial v_3}{\partial x_1}, \frac{\partial v_2}{\partial x_1} - \frac{\partial v_1}{\partial x_2} \right).$$

Very loosely speaking, one can say that the curl of a vector field measures “the tendency of the field to swirl around”.

**Proposition 3.3.3.** Let  $\emptyset \neq U \subset \mathbb{R}^3$  be open, and let  $f: U \rightarrow \mathbb{R}$  be twice continuously differentiable. Then  $\operatorname{curl} \operatorname{grad} f = 0$  holds.

*Proof.* We have, by Theorem 3.2.5, that

$$\operatorname{curl} \operatorname{grad} f = \left( \frac{\partial}{\partial x_2} \frac{\partial f}{\partial x_3} - \frac{\partial}{\partial x_3} \frac{\partial f}{\partial x_2}, \frac{\partial}{\partial x_3} \frac{\partial f}{\partial x_1} - \frac{\partial}{\partial x_1} \frac{\partial f}{\partial x_3}, \frac{\partial}{\partial x_1} \frac{\partial f}{\partial x_2} - \frac{\partial}{\partial x_2} \frac{\partial f}{\partial x_1} \right) = 0$$

holds. □

**Definition 3.3.4.** Let  $\emptyset \neq U \subset \mathbb{R}^N$  be open, and let  $v: U \rightarrow \mathbb{R}^N$  be a partially differentiable vector field. Then the *divergence* of  $v$  is defined as

$$\operatorname{div} v := \sum_{j=1}^N \frac{\partial v_j}{\partial x_j}.$$

*Examples.*

1. Let  $\emptyset \neq U \subset \mathbb{R}^N$  be open, and let  $v: U \rightarrow \mathbb{R}^N$  and  $f: U \rightarrow \mathbb{R}$  be partially differentiable. Since

$$\frac{\partial}{\partial x_j}(fv_j) = \frac{\partial f}{\partial x_j}v_j + f \frac{\partial v_j}{\partial x_j}$$

for  $j = 1, \dots, N$ , it follows that

$$\begin{aligned} \operatorname{div} fv &= \sum_{j=1}^N \frac{\partial}{\partial x_j}(fv_j) \\ &= \sum_{j=1}^N \frac{\partial f}{\partial x_j}v_j + f \sum_{j=1}^N \frac{\partial v_j}{\partial x_j} \\ &= \nabla f \cdot v + f \operatorname{div} v. \end{aligned}$$

2. Let

$$v: \mathbb{R}^N \setminus \{0\} \rightarrow \mathbb{R}^N, \quad x \mapsto \frac{x}{\|x\|}.$$

Then  $v = fu$  with

$$u(x) = x \quad \text{and} \quad f(x) = \frac{1}{\|x\|} = \frac{1}{\sqrt{x_1^2 + \cdots + x_N^2}}$$

for  $x \in \mathbb{R}^N \setminus \{0\}$ . It follows that

$$\frac{\partial f}{\partial x_j}(x) = -\frac{1}{2} \frac{2x_j}{\sqrt{x_1^2 + \cdots + x_N^2}^3} = -\frac{x_j}{\|x\|^3}$$

for  $j = 1, \dots, N$  and thus

$$\nabla f(x) = -\frac{x}{\|x\|^3}.$$

for  $x \in \mathbb{R}^N \setminus \{0\}$ . By the previous example, we thus have

$$\begin{aligned} (\operatorname{div} v)(x) &= (\nabla f)(x) \cdot x + \frac{1}{\|x\|} \underbrace{(\operatorname{div} u)(x)}_{=N} \\ &= -\frac{x \cdot x}{\|x\|^3} + \frac{N}{\|x\|} \\ &= \frac{N-1}{\|x\|} \end{aligned}$$

for  $x \in \mathbb{R}^N \setminus \{0\}$ .

**Definition 3.3.5.** Let  $\emptyset \neq U \subset \mathbb{R}^N$  be open, and let  $f: U \rightarrow \mathbb{R}$  be twice partially differentiable. Then the *Laplace operator*  $\Delta$  of  $f$  is defined as

$$\Delta f = \sum_{j=1}^N \frac{\partial^2 f}{\partial x_j^2} = \operatorname{div} \operatorname{grad} f.$$

*Example.* The Laplace operator occurs in several important partial differential equations:

- Let  $\emptyset \neq U \subset \mathbb{R}^N$  be open. Then the functions  $f: U \rightarrow \mathbb{R}$  solving the *potential equation*

$$\Delta f = 0$$

are called *harmonic functions*.

- Let  $\emptyset \neq U \subset \mathbb{R}^N$  be open, and let  $I \subset \mathbb{R}$  be an open interval. Then a function  $f: U \times I \rightarrow \mathbb{R}$  is said to solve the *wave equation* if

$$\Delta f - \frac{1}{c^2} \frac{\partial^2 f}{\partial t^2} = 0$$

and the *heat equation* if

$$\Delta f - \frac{1}{c^2} \frac{\partial f}{\partial t} = 0,$$

where  $c > 0$  is a constant. (Here, the Laplace operator is taken with respect to the first  $N$  coordinates only, i.e.,  $\Delta f = \sum_{j=1}^N \frac{\partial^2 f}{\partial x_j^2}$ .)

### Exercises

1. Let  $\emptyset \neq U \subset \mathbb{R}^3$  be open, and let  $f, g : U \rightarrow \mathbb{R}$  be twice continuously partially differentiable. Show that  $\operatorname{div}(\nabla f \times \nabla g) = 0$  on  $U$ , where  $\times$  denotes the cross product in  $\mathbb{R}^3$ .

2. Compute  $\Delta f$  for

$$f : \mathbb{R}^3 \setminus \{(0, 0, 0)\} \rightarrow \mathbb{R}, \quad (x, y, z) \mapsto \frac{1}{\sqrt{x^2 + y^2 + z^2}}.$$

3. Let  $\emptyset \neq U \subset \mathbb{R}^N$  be open, and let  $f, g : U \rightarrow \mathbb{R}$  be twice partially differentiable. Show that

$$\Delta(fg) = f\Delta g + 2(\nabla f) \cdot (\nabla g) + (\Delta f)g.$$

4. Let  $f : \mathbb{R} \rightarrow \mathbb{R}$  be twice continuously differentiable, let  $c > 0$  and  $v \in \mathbb{R}^N$  be arbitrary, and let  $\omega := c\|v\|$ . Show that

$$F : \mathbb{R}^N \times \mathbb{R} \rightarrow \mathbb{R}, \quad (x, t) \mapsto f(x \cdot v - \omega t)$$

solves the *wave equation*

$$\Delta F - \frac{1}{c^2} \frac{\partial^2 F}{\partial t^2} = 0,$$

where  $\Delta$  denotes the *spatial* Laplace operator, i.e.,

$$\Delta F = \sum_{j=1}^N \frac{\partial^2 F}{\partial x_j^2}.$$

5. Show that the function

$$f : \mathbb{R}^N \times (\mathbb{R} \setminus \{0\}) \rightarrow \mathbb{R}, \quad (x, t) \mapsto \frac{1}{t^{\frac{N}{2}}} \exp\left(-\frac{\|x\|^2}{4t}\right)$$

solves the *heat equation*

$$\Delta f - \frac{\partial f}{\partial t} = 0,$$

where again  $\Delta$  stands for the spatial Laplace operator.

### 3.4 Total Differentiability

One of the drawbacks of partial differentiability is that partially differentiable functions may well be discontinuous. We now introduce a stronger notion of differentiability in several variables that—as will turn out—implies continuity:

**Definition 3.4.1.** Let  $\emptyset \neq D \subset \mathbb{R}^N$ , and let  $x_0 \in \text{int } D$ . Then  $f : D \rightarrow \mathbb{R}^M$  is called [totally] differentiable at  $x_0$  if there is a linear map  $T : \mathbb{R}^N \rightarrow \mathbb{R}^M$  such that

$$\lim_{\substack{h \rightarrow 0 \\ h \neq 0}} \frac{\|f(x_0 + h) - f(x_0) - Th\|}{\|h\|} = 0. \quad (3.1)$$

If  $N = 2$  and  $M = 1$ , then the total differentiability of  $f$  at  $x_0$  can be interpreted as follows: the function  $f : D \rightarrow \mathbb{R}$  models a two-dimensional surface, and if  $f$  is totally differentiable at  $x_0$ , we can put a tangent plane—described by  $T$ —to that surface.

**Theorem 3.4.2.** Let  $\emptyset \neq D \subset \mathbb{R}^N$ , let  $x_0 \in \text{int } D$ , and let  $f : D \rightarrow \mathbb{R}^M$  be differentiable at  $x_0$ . Then:

- (i)  $f$  is continuous at  $x_0$ ;
- (ii)  $f$  is partially differentiable at  $x_0$ , and the linear map  $T$  in (3.1) is given by the matrix

$$J_f(x_0) = \begin{bmatrix} \frac{\partial f_1}{\partial x_1}(x_0), & \dots, & \frac{\partial f_1}{\partial x_N}(x_0) \\ \vdots & \ddots & \vdots \\ \frac{\partial f_M}{\partial x_1}(x_0), & \dots, & \frac{\partial f_M}{\partial x_N}(x_0) \end{bmatrix}.$$

*Proof.* Since

$$\lim_{\substack{h \rightarrow 0 \\ h \neq 0}} \frac{\|f(x_0 + h) - f(x_0) - Th\|}{\|h\|} = 0,$$

we have

$$\lim_{\substack{h \rightarrow 0 \\ h \neq 0}} \|f(x_0 + h) - f(x_0) - Th\| = 0.$$

Since  $\lim_{h \rightarrow 0} Th = 0$  holds, we have  $\lim_{h \rightarrow 0} \|f(x_0 + h) - f(x_0)\| = 0$ . This proves (i).

Let

$$A := \begin{bmatrix} a_{1,1}, & \dots, & a_{1,N} \\ \vdots & \ddots & \vdots \\ a_{M,1}, & \dots, & a_{M,N} \end{bmatrix}$$

be such that  $T = T_A$ . Fix  $j \in \{1, \dots, N\}$ , and note that

$$\begin{aligned} 0 &= \lim_{\substack{h \rightarrow 0 \\ h \neq 0}} \frac{\|f(x_0 + he_j) - f(x_0) - T(he_j)\|}{\underbrace{\|he_j\|}_{=|h|}} \\ &= \lim_{\substack{h \rightarrow 0 \\ h \neq 0}} \left\| \frac{1}{h} [f(x_0 + he_j) - f(x_0)] - Te_j \right\|, \end{aligned}$$

so that

$$\lim_{\substack{h \rightarrow 0 \\ h \neq 0}} \frac{1}{h} [f(x_0 + he_j) - f(x_0)] = Te_j.$$

It follows that  $f$  is partially differentiable at  $x_0$  with respect to  $x_j$  with

$$\begin{bmatrix} \frac{\partial f_1}{\partial x_j}(x_0) \\ \vdots \\ \frac{\partial f_M}{\partial x_j}(x_0) \end{bmatrix} = Te_j = \begin{bmatrix} a_{1,j} \\ \vdots \\ a_{M,j} \end{bmatrix}.$$

This proves (ii). □

The linear map in (3.1) is called the *differential* of  $f$  at  $x_0$  and denoted by  $Df(x_0)$ . The matrix  $J_f(x_0)$  is called the *Jacobian matrix* of  $f$  at  $x_0$ .

*Examples.*

1. Each linear map  $T: \mathbb{R}^N \rightarrow \mathbb{R}^M$  is totally differentiable with  $DT(x) = T$  for each  $x \in \mathbb{R}^N$ .
2. Let  $M_N(\mathbb{R})$  be the  $N \times N$  matrices over  $\mathbb{R}$  (note that  $M_N(\mathbb{R}) = \mathbb{R}^{N^2}$ ). Let

$$f: M_N(\mathbb{R}) \rightarrow M_N(\mathbb{R}), \quad X \mapsto X^2.$$

Fix  $X_0 \in M_N(\mathbb{R})$ , and let  $H \in M_N(\mathbb{R}) \setminus \{0\}$ , so that

$$f(X_0 + H) = X_0^2 + X_0H + HX_0 + H^2$$

and hence

$$f(X_0 + H) - f(X_0) = X_0H + HX_0 + H^2.$$

Let

$$T: M_N(\mathbb{R}) \rightarrow M_N(\mathbb{R}), \quad X \mapsto X_0X + XX_0.$$

It follows that, for  $H \rightarrow 0$ ,

$$\frac{\|f(X_0 + H) - f(X_0) - TH\|}{\|H\|} = \frac{\|H^2\|}{\|H\|} = \left\| \underbrace{H}_{\rightarrow 0} \underbrace{\frac{H}{\|H\|}}_{\text{bounded}} \right\| \rightarrow 0.$$

Hence,  $f$  is differentiable at  $X_0$  with  $Df(X_0)X = X_0X + XX_0$ .

The last of these two examples shows that it is often convenient to deal with the differential coordinate free, i.e., as a linear map, instead of with coordinates, i.e., as a matrix.

The following theorem provides a very useful sufficient condition for a function to be totally differentiable.



**Theorem 3.4.3.** *Let  $\emptyset \neq U \subset \mathbb{R}^N$  be open, let  $f: U \rightarrow \mathbb{R}^M$  be partially differentiable, and let  $x_0 \in U$  be such that  $\frac{\partial f}{\partial x_j}$  is continuous at  $x_0$  for  $j = 1, \dots, N$ . Then  $f$  is totally differentiable at  $x_0$ .*

*Proof.* Without loss of generality, let  $M = 1$ , and let  $U = B_\epsilon(x_0)$  for some  $\epsilon > 0$ . Let  $h = (h_1, \dots, h_N) \in \mathbb{R}^N$  with  $0 < \|h\| < \epsilon$ . For  $k = 0, \dots, N$ , let

$$x^{(k)} := x_0 + \sum_{j=1}^k h_j \mathbf{e}_j.$$

It follows that

- $x^{(0)} = x_0$ ,
- $x^{(N)} = x_0 + h$ ,
- and  $x^{(k-1)}$  and  $x^{(k)}$  differ only in the  $k$ -th coordinate.

For each  $k = 1, \dots, N$ , let

$$g_k: (-\epsilon, \epsilon) \rightarrow \mathbb{R}, \quad t \mapsto f(x^{(k-1)} + t\mathbf{e}_k);$$

it is clear that  $g_k$  is differentiable and that  $g_k(0) = f(x^{(k-1)})$  and  $g_k(h_k) = f(x^{(k)})$ . By the Mean Value Theorem, there is  $\xi_k$  with  $|\xi_k| \leq |h_k|$  such that

$$f(x^{(k)}) - f(x^{(k-1)}) = g_k(h_k) - g_k(0) = g'_k(\xi_k)h_k = \frac{\partial f}{\partial x_k}(x^{(k-1)} + \xi_k \mathbf{e}_k)h_k.$$

This, in turn, yields

$$f(x_0 + h) - f(x_0) = \sum_{j=1}^N (f(x^{(j)}) - f(x^{(j-1)})) = \sum_{j=1}^N \frac{\partial f}{\partial x_j}(x^{(j-1)} + \xi_j \mathbf{e}_j)h_j.$$

It follows that

$$\begin{aligned} & \frac{|f(x_0 + h) - f(x_0) - \sum_{j=1}^N \frac{\partial f}{\partial x_j}(x_0)h_j|}{\|h\|} \\ &= \frac{1}{\|h\|} \left| \sum_{j=1}^N \left( \frac{\partial f}{\partial x_j}(x^{(j-1)} + \xi_j \mathbf{e}_j) - \frac{\partial f}{\partial x_j}(x_0) \right) h_j \right| \\ &= \frac{1}{\|h\|} \left| \left( \frac{\partial f}{\partial x_1}(x^{(0)} + \xi_1 \mathbf{e}_1) - \frac{\partial f}{\partial x_1}(x_0), \dots, \frac{\partial f}{\partial x_N}(x^{(N-1)} + \xi_N \mathbf{e}_N) - \frac{\partial f}{\partial x_N}(x_0) \right) \cdot h \right| \\ &\leq \left\| \left( \frac{\partial f}{\partial x_1}(x^{(0)} + \xi_1 \mathbf{e}_1) - \frac{\partial f}{\partial x_1}(x_0), \dots, \frac{\partial f}{\partial x_N}(x^{(N-1)} + \xi_N \mathbf{e}_N) - \frac{\partial f}{\partial x_N}(x_0) \right) \right\| \quad (3.2) \end{aligned}$$

where the last estimate is due to the Cauchy–Schwarz Inequality.

As  $|\xi_k| \leq |h_k|$  for  $k = 1, \dots, N$ , we have  $\xi_1, \dots, \xi_k \rightarrow 0$  as  $h \rightarrow 0$  and therefore

$$x^{(k-1)} + \xi_k e_k \rightarrow x_0$$

for  $k = 1, \dots, N - 1$ . As  $\frac{\partial f}{\partial x_1}, \dots, \frac{\partial f}{\partial x_N}$  are continuous at  $x_0$  this means that

$$\frac{\partial f}{\partial x_k}(x^{(k-1)} + \xi_k e_k) \rightarrow \frac{\partial f}{\partial x_k}(x_0),$$

i.e., the right hand side of the inequality (3.2) tends to zero as  $h \rightarrow 0$ . Consequently, the left hand side of (3.2) converges to zero as well as  $h \rightarrow 0$ , i.e.,  $f$  is totally differentiable at  $x_0$ .  $\square$

**Corollary 3.4.4.** *Let  $\emptyset \neq U \subset \mathbb{R}^N$  be open, let  $f: U \rightarrow \mathbb{R}^M$  be continuously partially differentiable. Then  $f$  is totally differentiable on  $U$ , i.e., totally differentiable at each point of  $U$ .*

Very often, we can spot immediately that a function is continuously partially differentiable *without* explicitly computing the partial derivatives. We then know that the function has to be totally differentiable (and, in particular, continuous).

**Theorem 3.4.5** (Chain Rule). *Let  $\emptyset \neq U \subset \mathbb{R}^N$  and  $\emptyset \neq V \subset \mathbb{R}^M$  be open, and let  $g: U \rightarrow \mathbb{R}^M$  and  $f: V \rightarrow \mathbb{R}^K$  be functions with  $g(U) \subset V$  such that  $g$  is differentiable at  $x_0 \in U$  and  $f$  is differentiable at  $g(x_0) \in V$ . Then  $f \circ g: U \rightarrow \mathbb{R}^K$  is differentiable at  $x_0$  such that*

$$D(f \circ g)(x_0) = Df(g(x_0))Dg(x_0)$$

and

$$J_{f \circ g}(x_0) = J_f(g(x_0))J_g(x_0).$$

*Proof.* Since  $g$  is differentiable at  $x_0$ , there is  $\theta > 0$  such that

$$\frac{\|g(x_0 + h) - g(x_0) - Dg(x_0)h\|}{\|h\|} \leq 1$$

for  $0 < \|h\| < \theta$ . Consequently, we have for all  $h \in \mathbb{R}^N$  with  $0 < \|h\| < \theta$  that

$$\begin{aligned} \|g(x_0 + h) - g(x_0)\| &\leq \|g(x_0 + h) - g(x_0) - Dg(x_0)h\| + \|Dg(x_0)h\| \leq \underbrace{(1 + \|Dg(x_0)\|)}_{=: C} \|h\|. \end{aligned}$$

Let  $\epsilon > 0$ . Then there is  $\delta \in (0, \theta)$  such that

$$\|f(g(x_0) + h) - f(g(x_0)) - Df(g(x_0))h\| < \frac{\epsilon}{C} \|h\|$$

for  $\|h\| < C\delta$ . Choose  $\|h\| < \delta$ , so that  $\|g(x_0 + h) - g(x_0)\| < C\delta$ . It follows that

$$\begin{aligned} \|f(g(x_0 + h)) - f(g(x_0)) - Df(g(x_0))[g(x_0 + h) - g(x_0)]\| \\ < \frac{\epsilon}{C} \|g(x_0 + h) - g(x_0)\| \leq \epsilon \|h\|. \end{aligned}$$

We conclude that

$$\lim_{\substack{h \rightarrow 0 \\ h \neq 0}} \frac{f(g(x_0 + h)) - f(g(x_0)) - Df(g(x_0))[g(x_0 + h) - g(x_0)]}{\|h\|} = 0.$$

Let  $h \neq 0$ , and note that

$$\begin{aligned} \frac{\|f(g(x_0 + h)) - f(g(x_0)) - Df(g(x_0))Dg(x_0)h\|}{\|h\|} \\ \leq \frac{\|f(g(x_0 + h)) - f(g(x_0)) - Df(g(x_0))[g(x_0 + h) - g(x_0)]\|}{\|h\|} \end{aligned} \quad (3.3)$$

$$+ \frac{\|Df(g(x_0))[g(x_0 + h) - g(x_0)] - Df(g(x_0))Dg(x_0)h\|}{\|h\|} \quad (3.4)$$

As we have seen, the term in (3.3) tends to zero as  $h \rightarrow 0$ . For the term in (3.4), note that

$$\begin{aligned} \frac{\|Df(g(x_0))[g(x_0 + h) - g(x_0)] - Df(g(x_0))Dg(x_0)h\|}{\|h\|} \\ \leq \|Df(g(x_0))\| \underbrace{\frac{\|g(x_0 + h) - g(x_0) - Dg(x_0)h\|}{\|h\|}}_{\rightarrow 0} \rightarrow 0 \end{aligned}$$

as  $h \rightarrow 0$ . Hence,

$$\lim_{\substack{h \rightarrow 0 \\ h \neq 0}} \frac{\|f(g(x_0 + h)) - f(g(x_0)) - Df(g(x_0))Dg(x_0)h\|}{\|h\|} = 0$$

holds, which proves the claim.  $\square$

**Definition 3.4.6.** Let  $\emptyset \neq U \subset \mathbb{R}^N$  be open, let  $x_0 \in U$ , and let  $v \in \mathbb{R}^N$  be a *unit vector*, i.e., with  $\|v\| = 1$ . The *directional derivative* of  $f: U \rightarrow \mathbb{R}^M$  at  $x_0$  in the direction of  $v$  is defined as

$$\lim_{\substack{h \rightarrow 0 \\ h \neq 0}} \frac{f(x_0 + hv) - f(x_0)}{h}$$

and denoted by  $D_v f(x_0)$ .

**Theorem 3.4.7.** Let  $\emptyset \neq U \subset \mathbb{R}^N$  be open, and let  $f: U \rightarrow \mathbb{R}$  be totally differentiable at  $x_0 \in U$ . Then  $D_v f(x_0)$  exists for each  $v \in \mathbb{R}^N$  with  $\|v\| = 1$ , and we have

$$D_v f(x_0) = \nabla f(x_0) \cdot v.$$

*Proof.* Define

$$g: \mathbb{R} \rightarrow \mathbb{R}^N, \quad t \mapsto x_0 + tv.$$

Choose  $\epsilon > 0$  such small that  $g((-\epsilon, \epsilon)) \subset U$ . Let  $h := f \circ g$ . The chain rule yields that  $h$  is differentiable at 0 with

$$\begin{aligned} h'(0) &= Dh(0) \\ &= Df(g(0))Dg(0) \\ &= \sum_{j=1}^N \frac{\partial f}{\partial x_j}(g(0)) \underbrace{\frac{dg_j}{dt}(0)}_{=v_j} \\ &= \sum_{j=1}^N \frac{\partial f}{\partial x_j}(x_0)v_j \\ &= \nabla f(x_0) \cdot v. \end{aligned}$$

Since

$$h'(0) = \lim_{\substack{h \rightarrow 0 \\ h \neq 0}} \frac{f(x_0 + hv) - f(x_0)}{h} = D_v f(x_0),$$

this proves the claim.  $\square$

Theorem 3.4.7 allows for a geometric interpretation of the gradient: The gradient points in the direction in which the slope of the tangent line to the graph of  $f$  is maximal.

Existence of directional derivatives is stronger than partial differentiability, but weaker than total differentiability. We shall now see that—as for partial differentiability—the existence of directional derivatives need not imply continuity:

*Example.* Let

$$f: \mathbb{R}^2 \rightarrow \mathbb{R}, \quad (x, y) \mapsto \begin{cases} \frac{xy^2}{x^2+y^4}, & (x, y) \neq 0 \\ 0, & \text{otherwise.} \end{cases}$$

Let  $v = (v_1, v_2) \in \mathbb{R}^2$  such that  $\|v\| = 1$ , i.e.  $v_1^2 + v_2^2 = 1$ . For  $h \neq 0$ , we then have:

$$\frac{f(0 + hv) - f(0)}{h} = \frac{1}{h} \frac{h^3 v_1 v_2^2}{h^2 v_1^2 + h^4 v_2^4} = \frac{v_1 v_2^2}{v_1^2 + h^2 v_2^4}.$$

Hence, we obtain

$$D_v f(0) = \lim_{\substack{h \rightarrow 0 \\ h \neq 0}} \frac{f(0 + hv) - f(0)}{h} = \begin{cases} 0, & v_1 = 0, \\ \frac{v_2^2}{v_1}, & \text{otherwise.} \end{cases}$$

In particular,  $D_v f(0)$  exists for each  $v \in \mathbb{R}^2$  with  $\|v\| = 1$ . Nevertheless,  $f$  fails to be continuous at 0 because

$$\lim_{n \rightarrow \infty} f\left(\frac{1}{n^2}, \frac{1}{n}\right) = \lim_{n \rightarrow \infty} \frac{\frac{1}{n^4}}{\frac{1}{n^4} + \frac{1}{n^4}} = \frac{1}{2} \neq 0 = f(0).$$

**Exercises**

1. Determine the Jacobians of

$$\mathbb{R}^3 \rightarrow \mathbb{R}^3, \quad (r, \theta, \phi) \mapsto (r \sin \theta \cos \phi, r \sin \theta \sin \phi, r \cos \theta)$$

and

$$\mathbb{R}^3 \rightarrow \mathbb{R}^3, \quad (r, \theta, z) \mapsto (r \cos \theta, r \sin \theta, z).$$

2. Let
- $A \in M_N(\mathbb{R})$
- be symmetric. Show that

$$f: \mathbb{R}^N \rightarrow \mathbb{R}, \quad x \mapsto Ax \cdot x$$

is totally differentiable, and that

$$(Df)(x)\xi = 2Ax \cdot \xi$$

for  $x, \xi \in \mathbb{R}^N$ .

3. Let
- $N \in \mathbb{N}$
- , and show that

$$f: M_N(\mathbb{R}) \rightarrow M_N(\mathbb{R}), \quad X \mapsto X^3$$

is totally differentiable and determine its differential  $Df(X): M_N(\mathbb{R}) \rightarrow M_N(\mathbb{R})$  for each  $X \in M_N(\mathbb{R})$ .

4. An
- $N \times N$
- matrix
- $X$
- is
- invertible*
- if there is
- $X^{-1} \in M_N(\mathbb{R})$
- such that
- $XX^{-1} = X^{-1}X = I_N$
- where
- $I_N$
- denotes the unit matrix.

(a) Show that  $U := \{X \in M_N(\mathbb{R}) : X \text{ is invertible}\}$  is open. (*Hint:*  $X \in M_N(\mathbb{R})$  is invertible if and only if  $\det X \neq 0$ .)

(b) Show that the map

$$f: U \rightarrow M_N(\mathbb{R}), \quad X \mapsto X^{-1}$$

is totally differentiable on  $U$ , and calculate  $Df(X_0)$  for each  $X_0 \in U$ . (*Hint:* You may use that, by Cramer's Rule,  $f$  is continuous.)

5. Let

$$p: (\mathbb{R} \setminus \{0\}) \times \mathbb{R} \rightarrow \mathbb{R}^2, \quad (r, \theta) \mapsto (r \cos \theta, r \sin \theta),$$

let  $\emptyset \neq U \subset \mathbb{R}^2$  be open, and let  $f: U \rightarrow \mathbb{R}$  be twice continuously partially differentiable. Show that

$$(\Delta f) \circ p = \frac{\partial^2(f \circ p)}{\partial r^2} + \frac{1}{r} \frac{\partial(f \circ p)}{\partial r} + \frac{1}{r^2} \frac{\partial^2(f \circ p)}{\partial \theta^2}$$

on  $p^{-1}(U)$ . (*Hint:* Apply the chain rule twice.)

6. Let  $\emptyset \neq C \subset \mathbb{R}^N$  be open and connected, and let  $f: C \rightarrow \mathbb{R}$  be differentiable such that  $\nabla f \equiv 0$ . Show that  $f$  is constant. (*Hint*: First, treat the case where  $C$  is convex using the chain rule; then, for general  $C$ , assume that  $f$  is not constant, let  $x, y \in C$  such that  $f(x) \neq f(y)$ , and show that  $\{U, V\}$  with  $U := \{z \in C : f(z) = f(x)\}$  and  $V := \{z \in C : f(z) \neq f(x)\}$  is a disconnection for  $C$ .)

7. Let

$$f: \mathbb{R}^2 \rightarrow \mathbb{R}, \quad (x, y) \mapsto \begin{cases} \frac{xy^3}{x^2+y^4}, & (x, y) \neq (0, 0), \\ 0, & (x, y) = (0, 0). \end{cases}$$

Show that:

- (a)  $f$  is continuous at  $(0, 0)$ ;
- (b) for each  $v \in \mathbb{R}^2$  with  $\|v\| = 1$ , the directional derivative  $D_v f(0, 0)$  exists and equals 0;
- (c)  $f$  is not totally differentiable at  $(0, 0)$ .

(*Hint for (c)*: Assume towards a contradiction that  $f$  is totally differentiable at  $(0, 0)$ , and compute the first derivative of  $\mathbb{R} \ni t \mapsto f(t^2, t)$  at 0 first directly and then using the chain rule. What do you observe?)

8. Let  $\emptyset \neq U \subset \mathbb{R}^N$  be open, and let  $f: U \rightarrow \mathbb{R}$  be partially differentiable such that  $\frac{\partial f}{\partial x_1}, \dots, \frac{\partial f}{\partial x_N}$  are bounded. Show that  $f$  is continuous.

9. Let  $f: \mathbb{R}^2 \rightarrow \mathbb{R}$  be defined by

$$f(x, y) := \begin{cases} \frac{\sin(xy)}{x^2+y^2}, & \text{if } (x, y) \neq (0, 0), \\ 0, & \text{otherwise.} \end{cases}$$

Check—and justify—whether or not  $f$  is (a) partially differentiable, (b) continuous, (c) totally differentiable, and (d) continuously partially differentiable.

10. Let  $\emptyset \neq U \subset \mathbb{R}^N$  be open, and let  $f: U \rightarrow \mathbb{R}^M$  be continuously partially differentiable.

- (a) Let  $x \in U$ , and let  $\xi \in \mathbb{R}^N$  be such that  $\{x + t\xi : t \in [0, 1]\} \subset U$ . Show that

$$f(x + \xi) - f(x) = \int_0^1 J_f(x + t\xi)\xi dt.$$

- (b) Suppose that  $U$  is convex, and that  $\{\|J_f(x)\| : x \in U\}$  is bounded. Show that  $f$  is Lipschitz continuous.

### 3.5 Taylor's Theorem

We begin with a review of Taylor's theorem in one variable:

**Theorem 3.5.1** (Taylor's Theorem in One Variable). *Let  $I \subset \mathbb{R}$  be an interval, let  $n \in \mathbb{N}_0$ , and let  $f: I \rightarrow \mathbb{R}$  be  $n+1$  times differentiable. Then, for any  $x, x_0 \in I$ , there is  $\xi$  between  $x$  and  $x_0$  such that*

$$f(x) = \sum_{k=0}^n \frac{f^{(k)}(x_0)}{k!} (x - x_0)^k + \frac{f^{(n+1)}(\xi)}{(n+1)!} (x - x_0)^{n+1}.$$

*Proof.* Let  $x, x_0 \in I$  such that  $x \neq x_0$ . Choose  $y \in \mathbb{R}$  such that

$$f(x) = \sum_{k=0}^n \frac{f^{(k)}(x_0)}{k!} (x - x_0)^k + \frac{y}{(n+1)!} (x - x_0)^{n+1}.$$

Define

$$F(t) := f(x) - \sum_{k=0}^n \frac{f^{(k)}(t)}{k!} (x - t)^k - \frac{y}{(n+1)!} (x - t)^{n+1},$$

so that  $F(x_0) = F(x) = 0$ . By Rolle's Theorem, there is  $\xi$  strictly between  $x$  and  $x_0$  such that  $F'(\xi) = 0$ . Note that

$$\begin{aligned} F'(t) &= -f'(t) - \sum_{k=1}^n \left( \frac{f^{(k+1)}(t)}{k!} (x - t)^k - \frac{f^{(k)}(t)}{(k-1)!} (x - t)^{k-1} \right) + \frac{y}{n!} (x - t)^n \\ &= -\frac{f^{(n+1)}(t)}{n!} (x - t)^n + \frac{y}{n!} (x - t)^n, \end{aligned}$$

so that

$$0 = -\frac{f^{(n+1)}(\xi)}{n!} (x - \xi)^n + \frac{y}{n!} (x - \xi)^n$$

and thus  $y = f^{(n+1)}(\xi)$ . □

For  $n = 0$ , Taylor's Theorem is just the mean value theorem.

Taylor's theorem can be used to derive the so-called second derivative test for local extrema:

**Corollary 3.5.2** (Second Derivative Test). *Let  $I \subset \mathbb{R}$  be an open interval, let  $f: I \rightarrow \mathbb{R}$  be twice continuously differentiable, and let  $x_0 \in I$  such that  $f'(x_0) = 0$  and  $f''(x_0) < 0$  [ $f''(x_0) > 0$ ]. Then  $f$  has a local maximum [minimum] at  $x_0$ .*

*Proof.* Since  $f''$  is continuous, there is  $\epsilon > 0$  such that  $f''(x) < 0$  for all  $x \in (x_0 - \epsilon, x_0 + \epsilon)$ . Fix  $x \in (x_0 - \epsilon, x_0 + \epsilon)$ . By Taylor's Theorem, there is  $\xi$  between  $x$  and  $x_0$  such that

$$f(x) = f(x_0) + \underbrace{f'(x_0)(x - x_0)}_{=0} + \underbrace{\frac{f''(\xi)}{2} (x - x_0)^2}_{\substack{<0 \\ \geq 0}} \leq f(x_0),$$

which proves the claim. □

This proof of the second derivative test has a slight drawback compared with the usual one: we require  $f$  not only to be twice differentiable, but twice continuously differentiable. Its advantage is that it generalizes to the several variable situation.

To extend Taylor's Theorem to several variables, we introduce new notation.

A *multiindex* is an element  $\alpha = (\alpha_1, \dots, \alpha_N) \in \mathbb{N}_0^N$ . We define

$$|\alpha| := \alpha_1 + \dots + \alpha_N \quad \text{and} \quad \alpha! := \alpha_1! \cdots \alpha_N!$$

If  $f$  is  $|\alpha|$  times continuously partially differentiable, we let

$$D^\alpha f := \frac{\partial^\alpha f}{\partial x^\alpha} := \frac{\partial^{|\alpha|} f}{\partial x_1^{\alpha_1} \cdots \partial x_N^{\alpha_N}}.$$

Finally, for  $x = (x_1, \dots, x_N) \in \mathbb{R}^N$ , we let  $x^\alpha := x_1^{\alpha_1} \cdots x_N^{\alpha_N}$ .

We shall prove Taylor's Theorem in several variables through reduction to the one variable situation:

**Lemma 3.5.3.** *Let  $\emptyset \neq U \subset \mathbb{R}^N$  be open, let  $n \in \mathbb{N}_0$ , let  $f : U \rightarrow \mathbb{R}$  be  $n$  times continuously partially differentiable, and let  $x \in U$  and  $\xi \in \mathbb{R}^N$  be such that  $\{x + t\xi : t \in [0, 1]\} \subset U$ . Then*

$$g : [0, 1] \rightarrow \mathbb{R}, \quad t \mapsto f(x + t\xi)$$

*is  $n$  times continuously differentiable such that*

$$\frac{d^n g}{dt^n}(t) = \sum_{|\alpha|=n} \frac{n!}{\alpha!} D^\alpha f(x + t\xi) \xi^\alpha$$

*for  $t \in [0, 1]$ .*

*Proof.* We prove by induction on  $n$  that

$$\frac{d^n g}{dt^n}(t) = \sum_{j_1, \dots, j_n=1}^N D_{j_n} \cdots D_{j_1} f(x + t\xi) \xi_{j_1} \cdots \xi_{j_n}.$$

For  $n = 0$ , this is trivially true.

For the induction step from  $n - 1$  to  $n$ , simply note that

$$\begin{aligned} \frac{d^n g}{dt^n}(t) &= \frac{d}{dt} \left( \sum_{j_1, \dots, j_{n-1}=1}^N D_{j_{n-1}} \cdots D_{j_1} f(x + t\xi) \xi_{j_1} \cdots \xi_{j_{n-1}} \right) \\ &= \sum_{j=1}^N D_j \left( \sum_{j_1, \dots, j_{n-1}=1}^N D_{j_{n-1}} \cdots D_{j_1} f(x + t\xi) \xi_{j_1} \cdots \xi_{j_{n-1}} \right) \xi_j, \end{aligned}$$

by the Chain Rule,

$$= \sum_{j_1, \dots, j_n=1}^N D_{j_n} \cdots D_{j_1} f(x + t\xi) \xi_{j_1} \cdots \xi_{j_n}.$$



For  $(j_1, \dots, j_n) \in \{0, 1, \dots, N\}^n$  and  $k \in \{1, \dots, N\}$ , let  $\alpha_k$  denote the number of times  $k$  occurs among the coordinates of  $(j_1, \dots, j_n)$ , so that  $\alpha$  is a multiindex with  $|\alpha| = n$ . As  $f$  is  $n$  times continuously partially differentiable, we may change the order of differentiation, so that

$$D_{j_n} \cdots D_{j_1} f(x + t\xi) \xi_{j_1} \cdots \xi_{j_n} = D_1^{\alpha_1} \cdots D_N^{\alpha_N} f(x + t\xi) \xi_1^{\alpha_1} \cdots \xi_N^{\alpha_N}.$$

On the other hand, given a multiindex  $\alpha$  with  $|\alpha| = n$ , it is known from combinatorics that there are  $\frac{n!}{\alpha_1! \cdots \alpha_N!}$   $n$ -tuples  $(j_1, \dots, j_n) \in \{0, 1, \dots, N\}^n$  such that  $k$  occurs among its coordinates exactly  $\alpha_k$  times for  $k = 1, \dots, N$ . All in all, we obtain

$$\begin{aligned} \frac{d^n g}{dt^n}(t) &= \sum_{j_1, \dots, j_n=1}^N D_{j_n} \cdots D_{j_1} f(x + t\xi) \xi_{j_1} \cdots \xi_{j_n} \\ &= \sum_{|\alpha|=n} \frac{n!}{\alpha_1! \cdots \alpha_N!} D_1^{\alpha_1} \cdots D_N^{\alpha_N} f(x + t\xi) \xi_1^{\alpha_1} \cdots \xi_N^{\alpha_N} \\ &= \sum_{|\alpha|=n} \frac{n!}{\alpha!} D^\alpha f(x + t\xi) \xi^\alpha. \end{aligned}$$

as claimed.  $\square$

**Theorem 3.5.4** (Taylor's Theorem). *Let  $\emptyset \neq U \subset \mathbb{R}^N$  be open, let  $n \in \mathbb{N}_0$ , let  $f: U \rightarrow \mathbb{R}$  be  $n+1$  times continuously partially differentiable, and let  $x \in U$  and  $\xi \in \mathbb{R}^N$  be such that  $\{x + t\xi : t \in [0, 1]\} \subset U$ . Then there is  $\theta \in [0, 1]$  such that*

$$f(x + \xi) = \sum_{|\alpha| \leq n} \frac{1}{\alpha!} \frac{\partial^\alpha f}{\partial x^\alpha}(x) \xi^\alpha + \sum_{|\alpha|=n+1} \frac{1}{\alpha!} \frac{\partial^\alpha f}{\partial x^\alpha}(x + \theta\xi) \xi^\alpha. \quad (3.5)$$

*Proof.* Define

$$g: [0, 1] \rightarrow \mathbb{R}, \quad t \mapsto f(x + t\xi).$$

By Taylor's Theorem in one variable, there is  $\theta \in [0, 1]$  such that

$$g(1) = \sum_{k=0}^n \frac{g^{(k)}(0)}{k!} + \frac{g^{(n+1)}(\theta)}{(n+1)!}.$$

By Lemma 3.5.3, we have for  $k = 0, \dots, n$  that

$$\frac{g^{(k)}(0)}{k!} = \sum_{|\alpha|=k} \frac{1}{\alpha!} \frac{\partial^\alpha f}{\partial x^\alpha}(x) \xi^\alpha$$

as well as

$$\frac{g^{(n+1)}(\theta)}{(n+1)!} = \sum_{|\alpha|=n+1} \frac{1}{\alpha!} \frac{\partial^\alpha f}{\partial x^\alpha}(x + \theta\xi) \xi^\alpha.$$

Consequently, we obtain

$$f(x + \xi) = g(1) = \sum_{|\alpha| \leq n} \frac{1}{\alpha!} \frac{\partial^\alpha f}{\partial x^\alpha}(x) \xi^\alpha + \sum_{|\alpha|=n+1} \frac{1}{\alpha!} \frac{\partial^\alpha f}{\partial x^\alpha}(x + \theta \xi) \xi^\alpha.$$

as claimed.  $\square$

We shall now examine the terms of (3.5) up to order two:

- Clearly,

$$\sum_{|\alpha|=0} \frac{1}{\alpha!} \frac{\partial^\alpha f}{\partial x^\alpha}(x) \xi^\alpha = f(x)$$

holds.

- We have

$$\sum_{|\alpha|=1} \frac{1}{\alpha!} \frac{\partial^\alpha f}{\partial x^\alpha}(x) \xi^\alpha = \sum_{j=1}^N \frac{\partial f}{\partial x_j}(x) \xi_j = (\text{grad } f)(x) \cdot \xi.$$

- Finally, we obtain

$$\begin{aligned} \sum_{|\alpha|=2} \frac{1}{\alpha!} \frac{\partial^\alpha f}{\partial x^\alpha}(x) \xi^\alpha &= \sum_{j=1}^N \frac{1}{2} \frac{\partial^2 f}{\partial x_j^2}(x) \xi_j^2 + \sum_{j < k} \frac{\partial^2 f}{\partial x_j \partial x_k}(x) \xi_j \xi_k \\ &= \frac{1}{2} \sum_{j=1}^N \frac{\partial^2 f}{\partial x_j^2}(x) \xi_j^2 + \frac{1}{2} \sum_{j \neq k} \frac{\partial^2 f}{\partial x_j \partial x_k}(x) \xi_j \xi_k \\ &= \frac{1}{2} \sum_{j,k=1}^N \frac{\partial^2 f}{\partial x_j \partial x_k}(x) \xi_j \xi_k \\ &= \frac{1}{2} \left( \begin{bmatrix} \frac{\partial^2 f}{\partial x_1^2}(x), & \dots, & \frac{\partial^2 f}{\partial x_N \partial x_1}(x) \\ \vdots & \ddots & \vdots \\ \frac{\partial^2 f}{\partial x_1 \partial x_N}(x), & \dots, & \frac{\partial^2 f}{\partial x_N^2}(x) \end{bmatrix} \begin{bmatrix} \xi_1 \\ \vdots \\ \xi_N \end{bmatrix} \right) \cdot \begin{bmatrix} \xi_1 \\ \vdots \\ \xi_N \end{bmatrix} \\ &= \frac{1}{2} (\text{Hess } f)(x) \xi \cdot \xi, \end{aligned}$$

where

$$(\text{Hess } f)(x) := \begin{bmatrix} \frac{\partial^2 f}{\partial x_1^2}(x), & \dots, & \frac{\partial^2 f}{\partial x_N \partial x_1}(x) \\ \vdots & \ddots & \vdots \\ \frac{\partial^2 f}{\partial x_1 \partial x_N}(x), & \dots, & \frac{\partial^2 f}{\partial x_N^2}(x) \end{bmatrix}$$

is the so-called *Hessian* of  $f$  at  $x$ .

This yields the following, reformulation of Taylor's Theorem:

**Corollary 3.5.5.** Let  $\emptyset \neq U \subset \mathbb{R}^N$  be open, let  $f: U \rightarrow \mathbb{R}$  be twice continuously partially differentiable, and let  $x \in U$  and  $\xi \in \mathbb{R}^N$  be such that  $\{x + t\xi : t \in [0, 1]\} \subset U$ . Then there is  $\theta \in [0, 1]$  such that

$$f(x + \xi) = f(x) + (\text{grad } f)(x) \cdot \xi + \frac{1}{2}(\text{Hess } f)(x + \theta\xi)\xi \cdot \xi.$$

### Exercises

1. Let  $x, y \in \mathbb{R}$ . Show that there is  $\theta \in [0, 1]$  such that

$$\sin(x + y) = x + y - \frac{1}{2}(x^2 + 2xy + y^2) \sin(\theta(x + y)).$$

2. Let  $U \subset \mathbb{R}^N$  be open and convex and contain 0, let  $n \in \mathbb{N}_0$ , and let  $f: \mathbb{R}^N \rightarrow \mathbb{R}$  be  $n + 1$  times continuously partially differentiable such that  $\frac{\partial^\alpha f}{\partial x^\alpha} \equiv 0$  on  $U$  for all multiindices  $\alpha \in \mathbb{N}_0^N$  with  $|\alpha| = n + 1$ . Show that, there are  $(c_\alpha)_{\substack{\alpha \in \mathbb{N}_0^N \\ |\alpha| \leq n}}$  in  $\mathbb{R}$  such that

$$f(x) = \sum_{|\alpha| \leq n} c_\alpha x^\alpha$$

for all  $x \in U$ .

## 3.6 Classification of Stationary Points

In this section, we put Taylor's theorem to work to determine the local extrema of a function in several variables or rather, more generally, classify its so-called stationary points.

**Definition 3.6.1.** Let  $\emptyset \neq U \subset \mathbb{R}^N$  be open, and let  $f: U \rightarrow \mathbb{R}$  be partially differentiable. A point  $x_0 \in U$  is called *stationary* for  $f$  if  $\nabla f(x_0) = 0$ .

As we have seen in Theorem 3.2.4, all points where  $f$  attains a local extremum are stationary for  $f$ .

**Definition 3.6.2.** Let  $\emptyset \neq U \subset \mathbb{R}^N$  be open, and let  $f: U \rightarrow \mathbb{R}$  be partially differentiable. A stationary point  $x_0 \in U$  where  $f$  does not attain a local extremum is called a *saddle point* (for  $f$ ).



Figure 3.3: Saddle point = center of a Pringle

The notion of positive definiteness for a symmetric matrix and related ones—such as negative definiteness and indefiniteness—are defined in Section A.3.

**Lemma 3.6.3.** *Let  $\emptyset \neq U \subset \mathbb{R}^N$  be open, let  $f: U \rightarrow \mathbb{R}$  be twice continuously partially differentiable, and let  $x_0 \in U$  be such that that  $(\text{Hess } f)(x_0)$  is positive definite. Then there is  $\epsilon > 0$  such that  $B_\epsilon(x_0) \subset U$  and such that  $(\text{Hess } f)(x)$  is positive definite for all  $x \in B_\epsilon(x_0)$ .*

*Proof.* Since  $(\text{Hess } f)(x_0)$  is positive definite,

$$\det \begin{bmatrix} \frac{\partial^2 f}{\partial x_1^2}(x_0), & \dots, & \frac{\partial^2 f}{\partial x_K \partial x_1}(x_0) \\ \vdots & \ddots & \vdots \\ \frac{\partial^2 f}{\partial x_1 \partial x_K}(x_0), & \dots, & \frac{\partial^2 f}{\partial x_K^2}(x_0) \end{bmatrix} > 0$$

holds for  $K = 1, \dots, N$  by Theorem A.3.8. Since all second partial derivatives of  $f$  are continuous, there is, for each  $K = 1, \dots, N$ , an element  $\epsilon_K > 0$  such that  $B_{\epsilon_K}(x_0) \subset U$  and

$$\det \begin{bmatrix} \frac{\partial^2 f}{\partial x_1^2}(x), & \dots, & \frac{\partial^2 f}{\partial x_K \partial x_1}(x) \\ \vdots & \ddots & \vdots \\ \frac{\partial^2 f}{\partial x_1 \partial x_K}(x), & \dots, & \frac{\partial^2 f}{\partial x_K^2}(x) \end{bmatrix} > 0 \quad (3.6)$$

for all  $x \in B_{\epsilon_K}(x_0)$ . Let  $\epsilon := \min\{\epsilon_1, \dots, \epsilon_N\}$ , so that  $B_\epsilon(x_0) \subset U$  and (3.6) holds for all  $x \in B_\epsilon(x)$ . By Theorem A.3.8 again, this means that  $(\text{Hess } f)(x)$  is positive definite for all  $x \in B_\epsilon(x_0)$ .  $\square$

As for one variable, we can now formulate a second derivative test in several variables:

**Theorem 3.6.4** (Second Derivative Test). *Let  $\emptyset \neq U \subset \mathbb{R}^N$  be open, let  $f : U \rightarrow \mathbb{R}$  be twice continuously partially differentiable, and let  $x_0 \in U$  be a stationary point for  $f$ . Then:*

- (i) *if  $(\text{Hess } f)(x_0)$  is positive definite, then  $f$  has a local minimum at  $x_0$ ;*
- (ii) *if  $(\text{Hess } f)(x_0)$  is negative definite, then  $f$  has a local maximum at  $x_0$ ;*
- (iii) *if  $(\text{Hess } f)(x_0)$  is indefinite, then  $f$  has a saddle point at  $x_0$ .*

*Proof.* (i): By Lemma 3.6.3, there is  $\epsilon > 0$  such that  $B_\epsilon(x_0) \subset U$  and that  $(\text{Hess } f)(x)$  is positive definite for all  $x \in B_\epsilon(x_0)$ . Let  $\xi \in \mathbb{R}^N$  be such that  $0 < \|\xi\| < \epsilon$ . By Corollary 3.5.5, there is  $\theta \in [0, 1]$  such that

$$f(x_0 + \xi) = f(x_0) + \underbrace{(\text{grad } f)(x_0) \cdot \xi}_{=0} + \frac{1}{2} \underbrace{(\text{Hess } f)(x_0 + \theta\xi)\xi \cdot \xi}_{>0} > f(x_0).$$

Hence,  $f$  has a local minimum at  $x_0$ .

(ii) is proven similarly.

(iii): Suppose that  $(\text{Hess } f)(x_0)$  is indefinite. Then there are  $\lambda_1, \lambda_2 \in \mathbb{R}$  with  $\lambda_1 < 0 < \lambda_2$  and non-zero  $\xi_1, \xi_2 \in \mathbb{R}^N$  such that

$$(\text{Hess } f)(x_0)\xi_j = \lambda_j\xi_j$$

for  $j = 1, 2$ . Let  $\epsilon > 0$  be such that  $B_\epsilon(x_0) \subset U$ . Scaling  $\xi_1$  and  $\xi_2$  such that  $\|\xi_j\| < \epsilon$  for  $j = 1, 2$ , we can suppose without loss of generality that  $\{x_0 + t\xi_j : t \in [0, 1]\} \subset B_\epsilon(x_0)$  for  $j = 1, 2$ . Since

$$(\text{Hess } f)(x_0)\xi_j \cdot \xi_j = \lambda_j\|\xi_j\|^2 \begin{cases} < 0, & j = 1, \\ > 0, & j = 2, \end{cases}$$

the continuity of the second partial derivatives yields  $\delta \in (0, 1]$  such that

$$(\text{Hess } f)(x_0 + t\xi_1)\xi_1 \cdot \xi_1 < 0 \quad \text{and} \quad (\text{Hess } f)(x_0 + t\xi_2)\xi_2 \cdot \xi_2 > 0$$

for all  $t \in (0, \delta]$ . From Corollary 3.5.5, we obtain  $\theta_1, \theta_2 \in [0, 1]$  such that

$$f(x_0 + \delta\xi_j) = f(x_0) + \frac{\delta^2}{2} (\text{Hess } f)(x_0 + \theta_j\delta\xi_j)\xi_j \cdot \xi_j \begin{cases} < f(x_0), & j = 1, \\ > f(x_0), & j = 2. \end{cases}$$

Consequently, for any  $\epsilon > 0$  such that  $B_\epsilon(x_0) \subset U$ , we find  $x_1, x_2 \in B_\epsilon(x_0)$  such that  $f(x_1) < f(x_0) < f(x_2)$ . Hence,  $f$  must have a saddle point at  $x_0$ .  $\square$

*Example.* Let

$$f: \mathbb{R}^3 \rightarrow \mathbb{R}, \quad (x, y, z) \mapsto x^2 + y^2 + z^2 + 2xyz,$$

so that

$$\nabla f(x, y, z) = (2x + 2yz, 2y + 2zx, 2z + 2xy).$$

It is not hard to see that

$$\begin{aligned} \nabla f(x, y, z) = 0 \\ \iff (x, y, z) \in \{(0, 0, 0), (-1, 1, 1), (1, -1, 1), (1, 1, -1), (-1, -1, -1)\}. \end{aligned}$$

Hence,  $(0, 0, 0)$ ,  $(-1, 1, 1)$ ,  $(1, -1, 1)$ ,  $(1, 1, -1)$ , and  $(-1, -1, -1)$ , are the only stationary points of  $f$ .

Since

$$(\text{Hess } f)(x, y, z) = \begin{bmatrix} 2 & 2z & 2y \\ 2z & 2 & 2x \\ 2y & 2x & 2 \end{bmatrix},$$

it follows that

$$(\text{Hess } f)(0, 0, 0) = \begin{bmatrix} 2 & 0 & 0 \\ 0 & 2 & 0 \\ 0 & 0 & 2 \end{bmatrix}$$

is positive definite, so that  $f$  attains a local minimum at  $(0, 0, 0)$ .

To classify the other stationary points, first note that  $(\text{Hess } f)(x, y, z)$  cannot be negative definite at any point because  $2 > 0$ . Since

$$\det \begin{bmatrix} 2 & 2z \\ 2z & 2 \end{bmatrix} = 4 - 4z^2$$

is zero whenever  $z^2 = 1$ , it follows that  $(\text{Hess } f)(x, y, z)$  is not positive definite for all non-zero stationary points of  $f$ . Finally, we have

$$\begin{aligned} \det \begin{bmatrix} 2 & 2z & 2y \\ 2z & 2 & 2x \\ 2y & 2x & 2 \end{bmatrix} &= 2 \det \begin{bmatrix} 2 & 2x \\ 2x & 2 \end{bmatrix} - 2z \det \begin{bmatrix} 2z & 2x \\ 2y & 2 \end{bmatrix} + 2y \det \begin{bmatrix} 2z & 2 \\ 2y & 2x \end{bmatrix} \\ &= 2(4 - 4x^2) - 2z(4z - 4xy) + 2y(4zx - 4y) \\ &= 8 - 8x^2 - 8z^2 + 8xzy + 8xyz - 8y^2 \\ &= 8(1 - x^2 - y^2 - z^2 + 2xyz). \end{aligned}$$

This determinant is negative whenever  $|x| = |y| = |z| = 1$  and  $xyz = -1$ . Consequently,  $(\text{Hess } f)(x, y, z)$  is indefinite for all non-zero stationary points of  $f$ , so that  $f$  has a saddle point at those points.

**Corollary 3.6.5.** Let  $\emptyset \neq U \subset \mathbb{R}^2$  be open, let  $f: U \rightarrow \mathbb{R}$  be twice continuously partially differentiable, and let  $(x_0, y_0) \in U$  be such that

$$\frac{\partial f}{\partial x}(x_0, y_0) = \frac{\partial f}{\partial y}(x_0, y_0) = 0.$$

Then the following hold:

- (i) if  $\frac{\partial^2 f}{\partial x^2}(x_0, y_0) > 0$  and  $\frac{\partial^2 f}{\partial x^2}(x_0, y_0)\frac{\partial^2 f}{\partial y^2}(x_0, y_0) - \left(\frac{\partial^2 f}{\partial x \partial y}(x_0, y_0)\right)^2 > 0$ , then  $f$  has a local minimum at  $(x_0, y_0)$ ;
- (ii) if  $\frac{\partial^2 f}{\partial x^2}(x_0, y_0) < 0$  and  $\frac{\partial^2 f}{\partial x^2}(x_0, y_0)\frac{\partial^2 f}{\partial y^2}(x_0, y_0) - \left(\frac{\partial^2 f}{\partial x \partial y}(x_0, y_0)\right)^2 > 0$ , then  $f$  has a local maximum at  $(x_0, y_0)$ ;
- (iii) if  $\frac{\partial^2 f}{\partial x^2}(x_0, y_0)\frac{\partial^2 f}{\partial y^2}(x_0, y_0) - \left(\frac{\partial^2 f}{\partial x \partial y}(x_0, y_0)\right)^2 < 0$ , then  $f$  has a saddle point at  $(x_0, y_0)$ .

*Example.* Let

$$D := \{(x, y) \in \mathbb{R}^2 : 0 \leq x, y, x + y \leq \pi\},$$

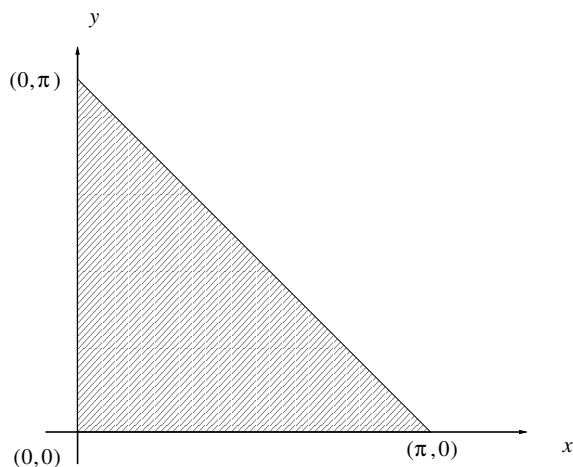

Figure 3.4: The domain  $D$

and let

$$f: D \rightarrow \mathbb{R}, \quad (x, y) \mapsto (\sin x)(\sin y) \sin(x + y).$$

It follows that  $f|_{\partial D} \equiv 0$  and that  $f(x) > 0$  for  $(x, y) \in \text{int } D$ .

Hence  $f$  has the global minimum 0, which is attained at each point of  $\partial D$ .

In the interior of  $D$ , we have

$$\frac{\partial f}{\partial x}(x, y) = (\cos x)(\sin y) \sin(x + y) + (\sin x)(\sin y) \cos(x + y)$$

and

$$\frac{\partial f}{\partial y}(x, y) = (\sin x)(\cos y) \sin(x + y) + (\sin x)(\sin y) \cos(x + y).$$

It follows that  $\frac{\partial f}{\partial x}(x, y) = \frac{\partial f}{\partial y}(x, y) = 0$  implies that

$$(\cos x) \sin(x + y) = -(\sin x) \cos(x + y)$$

and

$$(\cos y) \sin(x + y) = -(\sin y) \cos(x + y).$$

Division of the first equation by the second one yields

$$\frac{\cos x}{\cos y} = \frac{\sin x}{\sin y}$$

and thus  $\cot x = \cot y$ . It follows that  $x = y$ . Since  $\frac{\partial f}{\partial x}(x, x) = 0$  implies

$$0 = (\cos x) \sin(2x) + (\sin x) \cos(2x) = \sin(3x),$$

which—for  $x + x \in [0, \pi]$ —is true only for  $x = \frac{\pi}{3}$ , it follows that  $(\frac{\pi}{3}, \frac{\pi}{3})$  is the only stationary point of  $f$ .

It can be shown that

$$\frac{\partial^2 f}{\partial x^2} \left( \frac{\pi}{3}, \frac{\pi}{3} \right) = -\sqrt{3} < 0$$

and

$$\frac{\partial^2 f}{\partial x^2} \left( \frac{\pi}{3}, \frac{\pi}{3} \right) \frac{\partial^2 f}{\partial y^2} \left( \frac{\pi}{3}, \frac{\pi}{3} \right) - \left( \frac{\partial^2 f}{\partial x \partial y} \left( \frac{\pi}{3}, \frac{\pi}{3} \right) \right)^2 = \frac{9}{4} > 0.$$

Hence,  $f$  has a local (and thus global) maximum at  $(\frac{\pi}{3}, \frac{\pi}{3})$ , namely  $f(\frac{\pi}{3}, \frac{\pi}{3}) = \frac{3\sqrt{3}}{8}$ .

### Exercises

1. Determine and classify all stationary points of

$$f: \mathbb{R}^3 \rightarrow \mathbb{R}, \quad (x, y, z) \mapsto x^3 - 3x - y^3 + 9y + z^2.$$

If  $f$  attains a local minimum or maximum at one of its stationary points, evaluate it there.

2. Determine and classify the stationary points of

$$f: \mathbb{R}^2 \rightarrow \mathbb{R}, \quad (x, y) \mapsto (x^2 + 2y^2)e^{-(x^2+y^2)}.$$

If  $f$  has a local extremum at a stationary point, determine the nature of this extremum and evaluate  $f$  there.

3. Let  $c_1, \dots, c_p \in \mathbb{R}^N$ . For which  $x \in \mathbb{R}^N$  does  $\sum_{j=1}^p \|x - c_j\|^2$  become minimal?

4. Determine the minimum and the maximum of

$$f: D \rightarrow \mathbb{R}, \quad (x, y) \mapsto \sin x + \sin y + \sin(x + y),$$

where  $D := \{(x, y) \in \mathbb{R}^2 : 0 \leq x, y \leq \frac{\pi}{2}\}$ , and all points of  $D$  where they are attained.



# Chapter 4

## Integration in $\mathbb{R}^N$

### 4.1 Content in $\mathbb{R}^N$

What is the volume of a subset of  $\mathbb{R}^N$ ?

Let

$$I := [a_1, b_1] \times \cdots \times [a_N, b_N] \subset \mathbb{R}^N$$

be a compact  $N$ -dimensional interval. Then we define its (*Jordan content*)  $\mu(I)$  to be

$$\mu(I) := \prod_{j=1}^N (b_j - a_j).$$

For  $N = 1, 2, 3$ , the Jordan content of a compact interval is then just its intuitive length, area, volume.

To be able to meaningfully speak of the content of more general set, we first define what it means for a set to have content zero.

**Definition 4.1.1.** A set  $S \subset \mathbb{R}^N$  has *content zero* [ $\mu(S) = 0$ ] if, for each  $\epsilon > 0$ , there are compact intervals  $I_1, \dots, I_n \subset \mathbb{R}^N$  with

$$S \subset \bigcup_{j=1}^n I_j \quad \text{and} \quad \sum_{j=1}^n \mu(I_j) < \epsilon.$$

*Examples.*

1. Let  $x = (x_1, \dots, x_N) \in \mathbb{R}^N$ , and let  $\epsilon > 0$ . For  $\delta > 0$ , let

$$I_\delta := [x_1 - \delta, x_1 + \delta] \times \cdots \times [x_N - \delta, x_N + \delta].$$

It follows that  $x \in I_\delta$  and  $\mu(I_\delta) = 2^N \delta^N$ . Choose  $\delta > 0$  so small that  $2^N \delta^N < \epsilon$  and thus  $\mu(I_\delta) < \epsilon$ . It follows that  $\{x\}$  has content zero.

2. Let  $S_1, \dots, S_m \subset \mathbb{R}^N$  all have content zero. Let  $\epsilon > 0$ . Then, for  $j = 1, \dots, m$ , there are compact intervals  $I_1^{(j)}, \dots, I_{n_j}^{(j)} \subset \mathbb{R}^N$  such that

$$S_j \subset \bigcup_{k=1}^{n_j} I_k^{(j)} \quad \text{and} \quad \sum_{k=1}^{n_j} \mu(I_k^{(j)}) < \frac{\epsilon}{m}.$$

It follows that

$$S_1 \cup \dots \cup S_m \subset \bigcup_{j=1}^m \bigcup_{k=1}^{n_j} I_k^{(j)}$$

and

$$\sum_{j=1}^m \sum_{k=1}^{n_j} \mu(I_k^{(j)}) < m \frac{\epsilon}{m} = \epsilon.$$

Hence,  $S_1 \cup \dots \cup S_m$  has content zero. In view of the previous examples, this means in particular that all finite subsets of  $\mathbb{R}^N$  have content zero.

3. Let  $f: [0, 1] \rightarrow \mathbb{R}$  be continuous. We claim that  $\{(x, f(x)) : x \in [0, 1]\}$  has content zero in  $\mathbb{R}^2$ .

Let  $\epsilon > 0$ . Since  $f$  is uniformly continuous, there is  $\delta \in (0, 1)$  such that  $|f(x) - f(y)| \leq \frac{\epsilon}{4}$  for all  $x, y \in [0, 1]$  with  $|x - y| \leq \delta$ . Choose  $n \in \mathbb{N}$  such that  $n\delta < 1$  and  $(n+1)\delta \geq 1$ . For  $k = 0, \dots, n$ , let

$$I_k := [k\delta, (k+1)\delta] \times \left[ f(k\delta) - \frac{\epsilon}{4}, f(k\delta) + \frac{\epsilon}{4} \right].$$

Let  $x \in [0, 1]$ ; then there is  $k \in \{0, \dots, n\}$  such that  $x \in [k\delta, (k+1)\delta] \cap [0, 1]$ , so that  $|x - k\delta| \leq \delta$ . From the choice of  $\delta$ , it follows that  $|f(x) - f(k\delta)| \leq \frac{\epsilon}{4}$ , and thus  $f(x) \in [f(k\delta) - \frac{\epsilon}{4}, f(k\delta) + \frac{\epsilon}{4}]$ . It follows that  $(x, f(x)) \in I_k$ .

Since  $x \in [0, 1]$  was arbitrary, we obtain as a consequence that

$$\{(x, f(x)) : x \in [0, 1]\} \subset \bigcup_{k=0}^n I_k.$$

Moreover, we have

$$\sum_{k=0}^n \mu(I_k) = \sum_{k=0}^n \delta \frac{\epsilon}{2} = (n+1)\delta \frac{\epsilon}{2} \leq (1+\delta) \frac{\epsilon}{2} < \epsilon.$$

This proves the claim.

4. Let  $r > 0$ . We claim that

$$S := \{(x, y) \in \mathbb{R}^2 : x^2 + y^2 = r^2\}$$

has content zero.

Let

$$S_1 := \{(x, y) \in \mathbb{R}^2 : x^2 + y^2 = r^2, y \geq 0\},$$

and let

$$f: [-r, r] \rightarrow \mathbb{R}, \quad x \mapsto \sqrt{r^2 - x^2}.$$

Then  $f$  is continuous, and  $S_1 = \{(x, f(x)) : x \in [-r, r]\}$ . By the previous example,  $\mu(S_1) = 0$  holds. Similarly,

$$S_2 := \{(x, y) \in \mathbb{R}^2 : x^2 + y^2 = r^2, y \leq 0\}$$

has content zero. Hence,  $S = S_1 \cup S_2$  has content zero.

For an application later on, we require the following lemma:

**Lemma 4.1.2.** *A set  $S \subset \mathbb{R}^N$  does not have content zero if and only if, there is  $\epsilon_0 > 0$  such that, for any compact intervals  $I_1, \dots, I_n \subset \mathbb{R}^N$  with  $S \subset \bigcup_{j=1}^n I_j$ , we have*

$$\sum_{\substack{j=1 \\ \text{int } I_j \cap S \neq \emptyset}}^n \mu(I_j) \geq \epsilon_0.$$

*Proof.* Suppose that  $S$  does not have content zero. Then there is  $\tilde{\epsilon}_0 > 0$  such that, for any compact intervals  $I_1, \dots, I_n \subset \mathbb{R}^N$  with  $S \subset \bigcup_{j=1}^n I_j$ , we have  $\sum_{j=1}^n \mu(I_j) \geq \tilde{\epsilon}_0$ .

Set  $\epsilon_0 := \frac{\tilde{\epsilon}_0}{2}$ , and let  $I_1, \dots, I_n \subset \mathbb{R}^N$  a collection of compact intervals such that  $S \subset I_1 \cup \dots \cup I_n$ . We may suppose that there is  $m \in \{1, \dots, n\}$  such that

$$\text{int } I_j \cap S \neq \emptyset$$

for  $j = 1, \dots, m$  and that

$$I_j \cap S \subset \partial I_j$$

for  $j = m+1, \dots, n$ . Since boundaries of compact intervals always have content zero,

$$\bigcup_{j=m+1}^n I_j \cap S \subset \bigcup_{j=m+1}^n \partial I_j$$

has content zero. Hence, there are compact intervals  $J_1, \dots, J_k \subset \mathbb{R}^N$  such that

$$\bigcup_{j=m+1}^n I_j \cap S \subset \bigcup_{j=1}^k J_j \quad \text{and} \quad \sum_{j=1}^k \mu(J_j) < \frac{\tilde{\epsilon}_0}{2}.$$

Since

$$S \subset I_1 \cup \dots \cup I_m \cup J_1 \cup \dots \cup J_k,$$

we have

$$\tilde{\epsilon}_0 \leq \sum_{j=1}^m \mu(I_j) + \underbrace{\sum_{j=1}^k \mu(J_j)}_{< \frac{\tilde{\epsilon}_0}{2}},$$

which is possible only if

$$\sum_{j=1}^m \mu(I_j) \geq \frac{\tilde{\epsilon}_0}{2} = \epsilon_0.$$

This completes the proof.  $\square$

### **Exercises**

1. Let  $(x_n)_{n=1}^{\infty}$  be a convergent sequence in  $\mathbb{R}^N$  with limit  $x$ . Show that  $\{x_n : n \in \mathbb{N}\} \cup \{x\}$  has content zero.
2. Let  $I \subset \mathbb{R}^N$  be a compact interval. Show that  $\partial I$  has content zero.
3. Let  $I_1, \dots, I_n \subset \mathbb{R}$  be compact intervals such that  $\mathbb{Q} \cap [0, 1] \subset I_1 \cup \dots \cup I_n$ . Show that  $\sum_{j=1}^n \mu(I_j) \geq 1$ .

## 4.2 The Riemann Integral in $\mathbb{R}^N$

Let

$$I := [a_1, b_1] \times \dots \times [a_N, b_N].$$

For  $j = 1, \dots, N$ , let

$$a_j = t_{j,0} < t_{j,1} < \dots < t_{j,n_j} = b_j$$

and

$$\mathcal{P}_j := \{t_{j,k} : k = 0, \dots, n_j\}.$$

Then  $\mathcal{P} := \mathcal{P}_1 \times \dots \times \mathcal{P}_N$  is called a *partition* of  $I$ .

Each partition of  $I$  generates a subdivision of  $I$  into subintervals of the form

$$[t_{1,k_1}, t_{1,k_1+1}] \times [t_{2,k_2}, t_{2,k_2+1}] \times \dots \times [t_{N,k_N}, t_{N,k_N+1}];$$

these intervals only overlap at their boundaries (if at all).

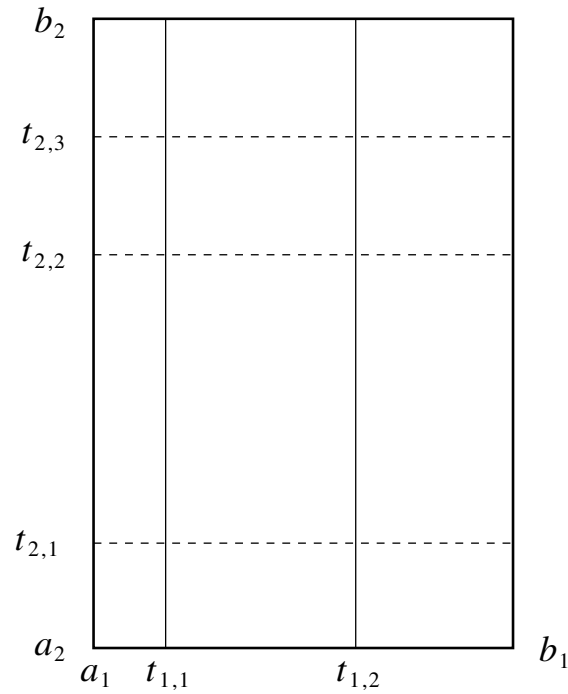

Figure 4.1: Subdivision generated by a partition

There are  $n_1 \cdots n_N$  such subintervals generated by  $\mathcal{P}$ .

**Definition 4.2.1.** Let  $I \subset \mathbb{R}^N$  be a compact interval, let  $f: I \rightarrow \mathbb{R}^M$  be a function, and let  $\mathcal{P}$  be a partition of  $I$  that generates a subdivision  $(I_\nu)_\nu$ . For each  $\nu$ , choose  $x_\nu \in I_\nu$ . Then

$$S(f, \mathcal{P}) := \sum_{\nu} f(x_\nu) \mu(I_\nu)$$

is called a *Riemann sum* of  $f$  corresponding to  $\mathcal{P}$ .

Note that a Riemann sum is dependent not only on the partition, but also on the particular choice of  $(x_\nu)_\nu$ .

Let  $\mathcal{P}$  and  $\mathcal{Q}$  be partitions of the compact interval  $I \subset \mathbb{R}^N$ . Then  $\mathcal{Q}$  called a *refinement* of  $\mathcal{P}$  if  $\mathcal{P}_j \subset \mathcal{Q}_j$  for all  $j = 1, \dots, N$ .

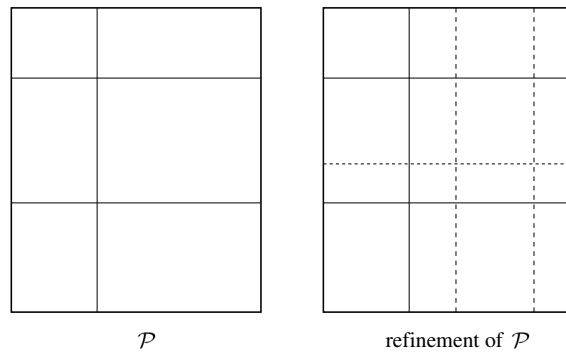

Figure 4.2: Subdivisions corresponding to a partition and to a refinement

If  $\mathcal{P}_1$  and  $\mathcal{P}_2$  are any two partitions of  $I$ , there is always a common refinement  $\mathcal{Q}$  of  $\mathcal{P}_1$  and  $\mathcal{P}_2$ .

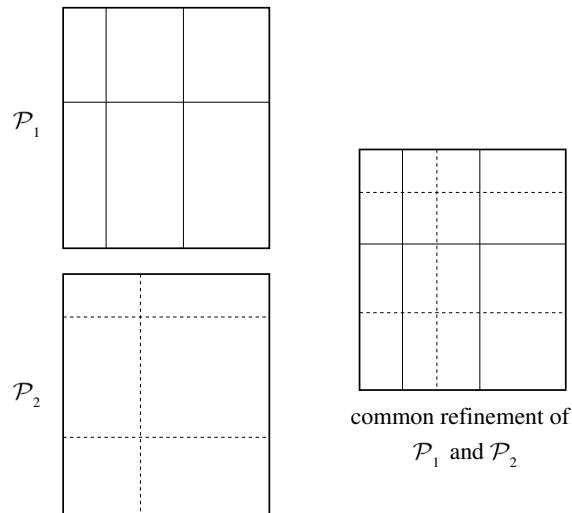

Figure 4.3: Subdivision corresponding to a common refinement

**Definition 4.2.2.** Let  $I \subset \mathbb{R}^N$  be a compact interval, let  $f : I \rightarrow \mathbb{R}^M$  be a function, and suppose that there is  $y \in \mathbb{R}^M$  with the following property: For each  $\epsilon > 0$ , there is a partition  $\mathcal{P}_\epsilon$  of  $I$  such that, for each refinement  $\mathcal{P}$  of  $\mathcal{P}_\epsilon$  and for any Riemann sum  $S(f, \mathcal{P})$  corresponding to  $\mathcal{P}$ , we have  $\|S(f, \mathcal{P}) - y\| < \epsilon$ . Then  $f$  is said to be *Riemann integrable* on  $I$ , and  $y$  is called the *Riemann integral* of  $f$  over  $I$ .

In the situation of Definition 4.2.2, we write

$$y =: \int_I f =: \int_I f d\mu =: \int_I f(x_1, \dots, x_N) d\mu(x_1, \dots, x_N).$$

The proof of the following is an easy exercise:

**Proposition 4.2.3.** *Let  $I \subset \mathbb{R}^N$  be a compact interval, and let  $f: I \rightarrow \mathbb{R}^M$  be Riemann integrable. Then  $\int_I f$  is unique.*

**Theorem 4.2.4** (Cauchy Criterion for Riemann Integrability). *Let  $I \subset \mathbb{R}^N$  be a compact interval, and let  $f: I \rightarrow \mathbb{R}^M$  be a function. Then the following are equivalent:*

- (i)  $f$  is Riemann integrable;
- (ii) for each  $\epsilon > 0$ , there is a partition  $\mathcal{P}_\epsilon$  of  $I$  such that, for all refinements  $\mathcal{P}$  and  $\mathcal{Q}$  of  $\mathcal{P}_\epsilon$  and for all Riemann sums  $S(f, \mathcal{P})$  and  $S(f, \mathcal{Q})$  corresponding to  $\mathcal{P}$  and  $\mathcal{Q}$ , respectively, we have  $\|S(f, \mathcal{P}) - S(f, \mathcal{Q})\| < \epsilon$ .

*Proof.* (i)  $\implies$  (ii): Let  $y := \int_I f$ , and let  $\epsilon > 0$ . Then there is a partition  $\mathcal{P}_\epsilon$  of  $I$  such that

$$\|S(f, \mathcal{P}) - y\| < \frac{\epsilon}{2}$$

for all refinements  $\mathcal{P}$  of  $\mathcal{P}_\epsilon$  and for all corresponding Riemann sums  $S(f, \mathcal{P})$ . Let  $\mathcal{P}$  and  $\mathcal{Q}$  be any two refinements of  $\mathcal{P}_\epsilon$ , and let  $S(f, \mathcal{P})$  and  $S(f, \mathcal{Q})$  be the corresponding Riemann sums. Then we have

$$\|S(f, \mathcal{P}) - S(f, \mathcal{Q})\| \leq \|S(f, \mathcal{P}) - y\| + \|S(f, \mathcal{Q}) - y\| < \frac{\epsilon}{2} + \frac{\epsilon}{2} = \epsilon,$$

which proves (ii).

(ii)  $\implies$  (i): For each  $n \in \mathbb{N}$ , there is a partition  $\mathcal{P}_n$  of  $I$  such that

$$\|S(f, \mathcal{P}) - S(f, \mathcal{Q})\| < \frac{1}{2^n}$$

for all refinements  $\mathcal{P}$  and  $\mathcal{Q}$  of  $\mathcal{P}_n$  and for all Riemann sums  $S(f, \mathcal{P})$  and  $S(f, \mathcal{Q})$  corresponding to  $\mathcal{P}$  and  $\mathcal{Q}$ , respectively. Without loss of generality suppose that  $\mathcal{P}_{n+1}$  is a refinement of  $\mathcal{P}_n$ . For each  $n \in \mathbb{N}$ , fix a particular Riemann sum  $S_n := S(f, \mathcal{P}_n)$ . For  $n > m$ , we then have

$$\|S_n - S_m\| \leq \sum_{k=m}^{n-1} \|S_{k+1} - S_k\| < \sum_{k=m}^{n-1} \frac{1}{2^k},$$

so that  $(S_n)_{n=1}^\infty$  is a Cauchy sequence in  $\mathbb{R}^M$ . Let  $y := \lim_{n \rightarrow \infty} S_n$ . We claim that  $y = \int_Y f$ .

Let  $\epsilon > 0$ , and choose  $n_0$  so large that  $\frac{1}{2^{n_0}} < \frac{\epsilon}{2}$  and  $\|S_{n_0} - y\| < \frac{\epsilon}{2}$ . Let  $\mathcal{P}$  be a refinement of  $\mathcal{P}_{n_0}$ , and let  $S(f, \mathcal{P})$  be a Riemann sum corresponding to  $\mathcal{P}$ . Then we have

$$\|S(f, \mathcal{P}) - y\| \leq \underbrace{\|S(f, \mathcal{P}) - S_{n_0}\|}_{< \frac{1}{2^{n_0}} < \frac{\epsilon}{2}} + \underbrace{\|S_{n_0} - y\|}_{< \frac{\epsilon}{2}} < \epsilon.$$

This proves (i). □

The Cauchy Criterion for Riemann Integrability has a somewhat surprising—and very useful—corollary. For its proof, we require the following lemma of which the proof is elementary, but unpleasant (and thus omitted):

**Lemma 4.2.5.** *Let  $I \subset \mathbb{R}^N$  be a compact interval, and let  $\mathcal{P}$  be a partition of  $I$  subdividing it into  $(I_\nu)_\nu$ . Then we have*

$$\mu(I) = \sum_{\nu} \mu(I_\nu).$$

**Corollary 4.2.6.** *Let  $I \subset \mathbb{R}^N$  be a compact interval, and let  $f: I \rightarrow \mathbb{R}^M$  be a function. Then the following are equivalent:*

- (i)  $f$  is Riemann integrable;
- (ii) for each  $\epsilon > 0$ , there is a partition  $\mathcal{P}_\epsilon$  of  $I$  such that  $\|S_1(f, \mathcal{P}_\epsilon) - S_2(f, \mathcal{P}_\epsilon)\| < \epsilon$  for any two Riemann sums  $S_1(f, \mathcal{P}_\epsilon)$  and  $S_2(f, \mathcal{P}_\epsilon)$  corresponding to  $\mathcal{P}_\epsilon$ .

*Proof.* (i)  $\implies$  (ii) is clear in the light of Theorem 4.2.4.

(i)  $\implies$  (i): Without loss of generality, suppose that  $M = 1$ .

Let  $(I_\nu)_\nu$  be the subdivisions of  $I$  corresponding to  $\mathcal{P}_\epsilon$ . Let  $\mathcal{P}$  and  $\mathcal{Q}$  be refinements of  $\mathcal{P}_\epsilon$  with subdivision  $(J_\mu)_\mu$  and  $(K_\lambda)_\lambda$  of  $I$ , respectively. Note that

$$\begin{aligned} & S(f, \mathcal{P}) - S(f, \mathcal{Q}) \\ &= \sum_{\mu} f(x_\mu) \mu(J_\mu) - \sum_{\lambda} f(y_\lambda) \mu(K_\lambda) = \sum_{\nu} \left( \sum_{J_\mu \subset I_\nu} f(x_\mu) \mu(J_\mu) - \sum_{K_\lambda \subset I_\nu} f(y_\lambda) \mu(K_\lambda) \right). \end{aligned}$$

For any index  $\nu$ , choose  $z_\nu^*, z_{\nu*} \in I_\nu$  such that

$$f(z_\nu^*) = \max\{f(x_\mu), f(y_\lambda) : J_\mu, K_\lambda \subset I_\nu\}$$

and

$$f(z_{\nu*}) = \min\{f(x_\mu), f(y_\lambda) : J_\mu, K_\lambda \subset I_\nu\}.$$

For  $\nu$ , we obtain

$$\begin{aligned} & (f(z_{\nu*}) - f(z_\nu^*)) \mu(I_\nu) \\ &= f(z_{\nu*}) \sum_{J_\mu \subset I_\nu} \mu(J_\mu) - f(z_\nu^*) \sum_{K_\lambda \subset I_\nu} \mu(K_\lambda), \quad \text{by Lemma 4.2.5,} \\ &\leq \sum_{J_\mu \subset I_\nu} f(x_\mu) \mu(J_\mu) - \sum_{K_\lambda \subset I_\nu} f(y_\lambda) \mu(K_\lambda) \\ &\leq f(z_\nu^*) \sum_{J_\mu \subset I_\nu} \mu(J_\mu) - f(z_{\nu*}) \sum_{K_\lambda \subset I_\nu} \mu(K_\lambda) \\ &= (f(z_\nu^*) - f(z_{\nu*})) \mu(I_\nu), \quad \text{by Lemma 4.2.5 again,} \end{aligned}$$



so that

$$\left| \sum_{J_\mu \subset I_\nu} f(x_\mu) \mu(J_\mu) - \sum_{K_\lambda \subset I_\nu} f(y_\lambda) \mu(K_\lambda) \right| \leq (f(z_\nu^*) - f(z_{\nu*})) \mu(I_\nu).$$

It follows that

$$\begin{aligned} |S(f, \mathcal{P}) - S(f, \mathcal{Q})| &\leq \sum_{\nu} (f(z_\nu^*) - f(z_{\nu*})) \mu(I_\nu) = \left| \underbrace{\sum_{\nu} f(z_\nu^*) \mu(I_\nu)}_{=S_1(f, \mathcal{P}_\epsilon)} - \underbrace{\sum_{\nu} f(z_{\nu*}) \mu(I_\nu)}_{=S_2(f, \mathcal{P}_\epsilon)} \right| < \epsilon, \end{aligned}$$

which completes the proof.  $\square$

**Theorem 4.2.7.** *Let  $I \subset \mathbb{R}^N$  be a compact interval, and let  $f: I \rightarrow \mathbb{R}^M$  be continuous. Then  $f$  is Riemann integrable.*

*Proof.* Since  $I$  is compact,  $f$  is uniformly continuous.

Let  $\epsilon > 0$ . Then there is  $\delta > 0$  such that  $\|f(x) - f(y)\| < \frac{\epsilon}{\mu(I)}$  for  $x, y \in I$  with  $\|x - y\| < \delta$ .

Choose a partition  $\mathcal{P}$  of  $I$  with the following property: If  $(I_\nu)_\nu$  is the subdivision of  $I$  generated by  $\mathcal{P}$ , then, for each

$$I_\nu := [a_1^{(\nu)}, b_1^{(\nu)}] \times \cdots \times [a_N^{(\nu)}, b_N^{(\nu)}],$$

we have

$$\max_{j=1, \dots, N} |a_j^{(\nu)} - b_j^{(\nu)}| < \frac{\delta}{\sqrt{N}}.$$

Let  $S_1(f, \mathcal{P})$  and  $S_2(f, \mathcal{P})$  be any two Riemann sums of  $f$  corresponding to  $\mathcal{P}$ , namely

$$S_1(f, \mathcal{P}) = \sum_{\nu} f(x_\nu) \mu(I_\nu) \quad \text{and} \quad S_2(f, \mathcal{P}) = \sum_{\nu} f(y_\nu) \mu(I_\nu)$$

with  $x_\nu, y_\nu \in I_\nu$ . Hence,

$$\|x_\nu - y_\nu\| = \sqrt{\sum_{j=1}^N (x_{\nu,j} - y_{\nu,j})^2} < \sqrt{\sum_{j=1}^N \frac{\delta^2}{N}} = \delta$$

holds, so that

$$\|S_1(f, \mathcal{P}) - S_2(f, \mathcal{P})\| \leq \sum_{\nu} \|f(x_\nu) - f(y_\nu)\| \mu(I_\nu) < \frac{\epsilon}{\mu(I)} \sum_{\nu} \mu(I_\nu) = \epsilon.$$

This completes the proof.  $\square$

Our next theorem improves Theorem 4.2.8 and has a similar, albeit technically more involved proof:

**Theorem 4.2.8.** *Let  $I \subset \mathbb{R}^N$  be a compact interval, and let  $f : I \rightarrow \mathbb{R}^M$  be bounded such that  $S := \{x \in I : f \text{ is discontinuous at } x\}$  has content zero. Then  $f$  is Riemann integrable.*

*Proof.* Let  $C \geq 0$  be such that  $\|f(x)\| \leq C$  for  $x \in I$ , and let  $\epsilon > 0$ .

Choose a partition  $\mathcal{P}$  of  $I$  such that

$$\sum_{I_\nu \cap S \neq \emptyset} \mu(I_\nu) < \frac{\epsilon}{4(C+1)}$$

holds for the corresponding subdivision  $(I_\nu)_\nu$  of  $I$ , and let

$$K := \bigcup_{I_\nu \cap S = \emptyset} I_\nu.$$

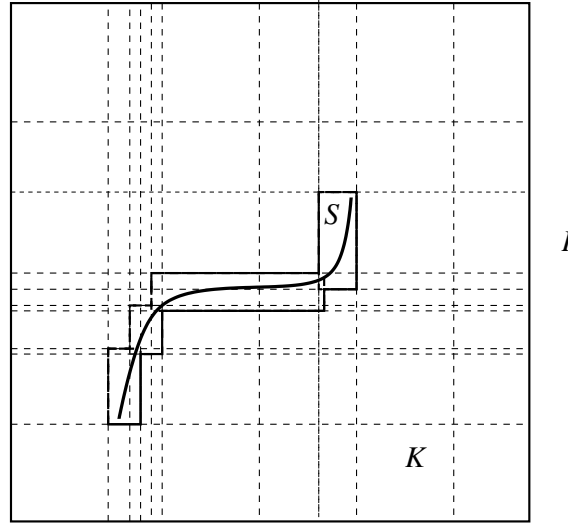

Figure 4.4: The idea of the proof of Theorem 4.2.8

Then  $K$  is compact, and  $f|_K$  is continuous; hence,  $f|_K$  is uniformly continuous.

Choose  $\delta > 0$  such that  $\|f(x) - f(y)\| < \frac{\epsilon}{2\mu(I)}$  for  $x, y \in K$  with  $\|x - y\| < \delta$ . Choose a partition  $\mathcal{Q}$  refining  $\mathcal{P}$  such that, for each interval  $J_\lambda$  in the corresponding subdivision  $(J_\lambda)_\lambda$  of  $I$  with

$$J_\lambda := [a_1^{(\lambda)}, b_1^{(\lambda)}] \times \cdots \times [a_N^{(\lambda)}, b_N^{(\lambda)}],$$

we have

$$\max_{j=1, \dots, N} |a_j^{(\lambda)} - b_j^{(\lambda)}| < \frac{\delta}{\sqrt{N}}.$$

Let  $S_1(f, \mathcal{Q})$  and  $S_2(f, \mathcal{Q})$  be any two Riemann sums of  $f$  corresponding to  $\mathcal{Q}$ , namely

$$S_1(f, \mathcal{Q}) = \sum_{\lambda} f(x_\lambda) \mu(J_\lambda) \quad \text{and} \quad S_2(f, \mathcal{Q}) = \sum_{\lambda} f(y_\lambda) \mu(J_\lambda).$$

It follows that

$$\begin{aligned}
\|S_1(f, \mathcal{Q}) - S_2(f, \mathcal{Q})\| &\leq \sum_{\lambda} \|f(x_{\lambda}) - f(y_{\lambda})\| \mu(J_{\lambda}) \\
&= \sum_{J_{\lambda} \not\subset K} \underbrace{\|f(x_{\lambda}) - f(y_{\lambda})\| \mu(J_{\lambda})}_{\leq 2C} + \sum_{J_{\lambda} \subset K} \underbrace{\|f(x_{\lambda}) - f(y_{\lambda})\| \mu(J_{\lambda})}_{< \frac{\epsilon}{2\mu(I)}} \\
&\leq 2C \sum_{J_{\lambda} \not\subset K} \mu(J_{\lambda}) + \underbrace{\frac{\epsilon}{2\mu(I)} \sum_{J_{\lambda} \subset K} \mu(J_{\lambda})}_{< \frac{\epsilon}{2}} \\
&\leq 2C \underbrace{\sum_{I_{\nu} \cap S \neq \emptyset} \mu(I_{\nu})}_{< \frac{\epsilon}{4(C+1)}} + \frac{\epsilon}{2} \\
&< \frac{\epsilon}{2} + \frac{\epsilon}{2} \\
&= \epsilon,
\end{aligned}$$

which proves the claim.  $\square$

Let  $\emptyset \neq D \subset \mathbb{R}^N$  be bounded, and let  $f: D \rightarrow \mathbb{R}^M$  be a function. Let  $I \subset \mathbb{R}^N$  be a compact interval such that  $D \subset I$ . Define

$$\tilde{f}: I \rightarrow \mathbb{R}^M, \quad x \mapsto \begin{cases} f(x), & x \in D, \\ 0, & x \notin D. \end{cases} \quad (4.1)$$

We say that  $f$  is Riemann integrable on  $D$  if  $\tilde{f}$  is Riemann integrable on  $I$ . We define

$$\int_D f := \int_I \tilde{f}.$$

It is easy to see that this definition is independent of the choice of  $I$ .

**Theorem 4.2.9.** *Let  $\emptyset \neq D \subset \mathbb{R}^N$  be bounded with  $\mu(\partial D) = 0$ , and let  $f: D \rightarrow \mathbb{R}^M$  be bounded and continuous. Then  $f$  is Riemann integrable on  $D$ .*

*Proof.* Define  $\tilde{f}$  as in (4.1). Then  $\tilde{f}$  is continuous at each point of  $\text{int } D$  as well as at each point of  $\text{int}(I \setminus D)$ . Consequently,

$$\{x \in I : \tilde{f} \text{ is discontinuous at } x\} \subset \partial D$$

has content zero. The claim then follows from Theorem 4.2.8.  $\square$

**Definition 4.2.10.** Let  $D \subset \mathbb{R}^N$  be bounded. We say that  $D$  has content if  $1$  is Riemann integrable on  $D$ . We write

$$\mu(D) := \int_D 1.$$

Sometimes, if we want to emphasize the dimension  $N$ , we write  $\mu_N(D)$ .

For any set  $S \subset \mathbb{R}^N$ , let its *indicator function* be

$$\chi_S: \mathbb{R}^N \rightarrow \mathbb{R}, \quad x \mapsto \begin{cases} 1, & x \in S, \\ 0, & x \notin S. \end{cases}$$

If  $D \subset \mathbb{R}^N$  is bounded, and  $I \subset \mathbb{R}^N$  is a compact interval with  $D \subset I$ , then Definition 4.2.10 becomes

$$\mu(D) = \int_I \chi_D.$$

It is important not to confuse the statements “ $D$  does not have content” and “ $D$  has content zero”: a set with content zero always has content.

The following theorem characterizes the sets that have content in terms of their boundaries:

**Theorem 4.2.11.** *The following are equivalent for a bounded set  $D \subset \mathbb{R}^N$ :*

- (i)  $D$  has content.
- (ii)  $\partial D$  has content zero.

*Proof.* (ii)  $\implies$  (i) is clear by Theorem 4.2.9.

(i)  $\implies$  (ii): Assume towards a contradiction that  $D$  has content, but that  $\partial D$  does not have content zero. By Lemma 4.1.2, this means that there is  $\epsilon_0 > 0$  such that, for any compact intervals  $I_1, \dots, I_n \subset \mathbb{R}^N$  with  $\partial D \subset \bigcup_{j=1}^n I_j$ , we have

$$\sum_{\substack{j=1 \\ \text{int } I_j \cap \partial D \neq \emptyset}}^n \mu(I_j) \geq \epsilon_0.$$

Let  $I \subset \mathbb{R}^N$  be a compact interval such that  $D \subset I$ . Choose a partition  $\mathcal{P}$  of  $I$  such that

$$|S(\chi_D, \mathcal{P}) - \mu(D)| < \frac{\epsilon_0}{2}$$

for any Riemann sum of  $\chi_D$  corresponding to  $\mathcal{P}$ . Let  $(I_\nu)_\nu$  be the subdivision of  $I$  corresponding to  $\mathcal{P}$ . Choose support points  $x_\nu \in I_\nu$  with  $x_\nu \in D$  whenever  $\text{int } I_\nu \cap \partial D \neq \emptyset$ . Let

$$S_1(\chi_D, \mathcal{P}) = \sum_{\nu} \chi_D(x_\nu) \mu(I_\nu).$$

Choose support points  $y_\nu \in I_\nu$  such that  $y_\nu = x_\nu$  if  $\text{int } I_\nu \cap \partial D = \emptyset$  and  $y_\nu \in D^c$  if  $\text{int } I_\nu \cap \partial D \neq \emptyset$ , and let

$$S_2(\chi_D, \mathcal{P}) = \sum_{\nu} \chi_D(y_\nu) \mu(I_\nu).$$

It follows that

$$S_1(\chi_D, \mathcal{P}) - S_2(\chi_D, \mathcal{P}) = \sum_{(\text{int } I_\nu) \cap \partial D \neq \emptyset} \mu(I_\nu) \geq \epsilon_0.$$

On the other hand, however, we have

$$|S_1(\chi_D, \mathcal{P}) - S_2(\chi_D, \mathcal{P})| \leq |S_1(\chi_D, \mathcal{P}) - \mu(D)| + |S_2(\chi_D, \mathcal{P}) - \mu(D)| < \epsilon_0,$$

which is a contradiction.  $\square$

Before we go ahead and actually compute Riemann integrals, let us summarize (and prove) a few properties of the Riemann integral:

**Proposition 4.2.12** (Properties of the Riemann Integral). *The following are true:*

- (i) *Let  $\emptyset \neq D \subset \mathbb{R}^N$  be bounded, let  $f, g: D \rightarrow \mathbb{R}^M$  be Riemann integrable on  $D$ , and let  $\lambda, \mu \in \mathbb{R}$ . Then  $\lambda f + \mu g$  is Riemann integrable on  $D$  such that*

$$\int_D (\lambda f + \mu g) = \lambda \int_D f + \mu \int_D g.$$

- (ii) *Let  $\emptyset \neq D \subset \mathbb{R}^N$  be bounded, and let  $f: D \rightarrow \mathbb{R}$  be non-negative and Riemann integrable on  $D$ . Then  $\int_D f$  is non-negative.*
- (iii) *Let  $\emptyset \neq D \subset \mathbb{R}^N$  be bounded, and let  $f: D \rightarrow \mathbb{R}^M$  be Riemann integrable on  $D$ . Then*

$$\|f\|: D \rightarrow \mathbb{R}, \quad x \mapsto \|f(x)\|$$

*is Riemann integrable with*

$$\left\| \int_D f \right\| \leq \int_D \|f\|.$$

- (iv) *Let  $D_1, D_2 \subset \mathbb{R}^N$  be non-empty and bounded such that  $\mu(D_1 \cap D_2) = 0$ , and let  $f: D_1 \cup D_2 \rightarrow \mathbb{R}^M$  be Riemann integrable on both  $D_1$  and  $D_2$ . Then  $f$  is Riemann integrable on  $D_1 \cup D_2$  such that*

$$\int_{D_1 \cup D_2} f = \int_{D_1} f + \int_{D_2} f.$$

- (v) *Let  $\emptyset \neq D \subset \mathbb{R}^N$  have content, let  $f: D \rightarrow \mathbb{R}$  be Riemann integrable, and let  $m, M \in \mathbb{R}$  be such that*

$$m \leq f(x) \leq M$$

*for  $x \in D$ . Then*

$$m \mu(D) \leq \int_D f \leq M \mu(D)$$

*holds.*

(vi) Let  $\emptyset \neq D \subset \mathbb{R}^N$  be compact, connected, and have content, and let  $f : D \rightarrow \mathbb{R}$  be continuous. Then there is  $x_0 \in D$  such that

$$\int_D f = f(x_0)\mu(D).$$

*Proof.* (i) is routine.

(ii): Without loss of generality, suppose that  $I$  is a compact interval. Assume that  $\int_I f < 0$ . Let  $\epsilon := -\int_I f > 0$ , and choose a partition  $\mathcal{P}$  of  $I$  such that for all Riemann sums  $S(f, \mathcal{P})$  corresponding to  $\mathcal{P}$ , the inequality

$$\left| S(f, \mathcal{P}) - \int_I f \right| < \frac{\epsilon}{2}$$

holds. It follows that

$$S(f, \mathcal{P}) < -\frac{\epsilon}{2} < 0,$$

whereas, on the other hand,

$$S(f, \mathcal{P}) = \sum_{\nu} f(x_{\nu})\mu(I_{\nu}) \geq 0,$$

where  $(I_{\nu})_{\nu}$  is the subdivision of  $I$  corresponding to  $\mathcal{P}$ .

(iii): Again, suppose that  $D$  is a compact interval  $I$ .

Let  $\epsilon > 0$ , and let  $f_1, \dots, f_M$  denote the components of  $f$ . By Corollary 4.2.6, there is a partition  $\mathcal{P}_{\epsilon}$  of  $I$  such that

$$|S_1(f_j, \mathcal{P}_{\epsilon}) - S_2(f_j, \mathcal{P}_{\epsilon})| < \frac{\epsilon}{M}$$

for  $j = 1, \dots, M$  and for all Riemann sums  $S_1(f_j, \mathcal{P}_{\epsilon})$  and  $S_2(f_j, \mathcal{P}_{\epsilon})$  corresponding to  $\mathcal{P}_{\epsilon}$ . Let  $(I_{\nu})_{\nu}$  be the subdivision of  $I$  induced by  $\mathcal{P}_{\epsilon}$ . Choose support points  $x_{\nu}, y_{\nu} \in I_{\nu}$ . Fix  $j \in \{1, \dots, M\}$ . Let  $z_{\nu}^*, z_{\nu*} \in \{x_{\nu}, y_{\nu}\}$  be such that

$$f_j(z_{\nu}^*) = \max\{f_j(x_{\nu}), f_j(y_{\nu})\} \quad \text{and} \quad f_j(z_{\nu*}) = \min\{f_j(x_{\nu}), f_j(y_{\nu})\}$$

We then have that

$$\begin{aligned} & \sum_{\nu} |f_j(x_{\nu}) - f_j(y_{\nu})|\mu(I_{\nu}) \\ &= \sum_{\nu} (f_j(z_{\nu}^*) - f_j(z_{\nu*}))\mu(I_{\nu}) = \sum_{\nu} f_j(z_{\nu}^*)\mu(I_{\nu}) - \sum_{\nu} f_j(z_{\nu*})\mu(I_{\nu}) < \frac{\epsilon}{M}. \end{aligned}$$

It follows that

$$\begin{aligned}
 \left| \sum_{\nu} \|f(x_{\nu})\| \mu(I_{\nu}) - \sum_{\nu} \|f(y_{\nu})\| \mu(I_{\nu}) \right| &\leq \sum_{\nu} \|f(x_{\nu}) - f(y_{\nu})\| \mu(I_{\nu}) \\
 &\leq \sum_{\nu} \sum_{j=1}^M |f_j(x_{\nu}) - f_j(y_{\nu})| \mu(I_{\nu}) \\
 &= \sum_{j=1}^M \sum_{\nu} |f_j(x_{\nu}) - f_j(y_{\nu})| \mu(I_{\nu}) \\
 &< M \frac{\epsilon}{M} \\
 &= \epsilon,
 \end{aligned}$$

so that  $\|f\|$  is Riemann integrable by Corollary 4.2.6.

Let  $\epsilon > 0$  and choose a partition  $\mathcal{P}$  of  $I$  with corresponding subdivision  $(I_{\nu})_{\nu}$  of  $I$  and support points  $x_{\nu} \in I_{\nu}$  such that

$$\left\| \sum_{\nu} f(x_{\nu}) \mu(I_{\nu}) - \int_I f \right\| < \frac{\epsilon}{2}$$

and

$$\left| \sum_{\nu} \|f(x_{\nu})\| \mu(I_{\nu}) - \int_I \|f\| \right| < \frac{\epsilon}{2}.$$

It follows that

$$\left\| \int_I f \right\| \leq \left\| \sum_{\nu} f(x_{\nu}) \mu(I_{\nu}) \right\| + \frac{\epsilon}{2} \leq \sum_{\nu} \|f(x_{\nu})\| \mu(I_{\nu}) + \frac{\epsilon}{2} \leq \int_I \|f\| + \epsilon.$$

Since  $\epsilon > 0$  was arbitrary, this means that  $\left\| \int_I f \right\| \leq \int_I \|f\|$ .

(iv): Choose a compact interval  $I \subset \mathbb{R}^N$  such that  $D_1, D_2 \subset I$ , and note that

$$\int_{D_j} f = \int_I \tilde{f} \chi_{D_j} = \int_{D_1 \cup D_2} f \chi_{D_j}$$

for  $j = 1, 2$ . In particular,  $f \chi_{D_1}$  and  $f \chi_{D_2}$  are Riemann integrable on  $D_1 \cup D_2$ . Since  $\mu(D_1 \cap D_2) = 0$ , the function  $f \chi_{D_1 \cap D_2}$  is automatically Riemann integrable, so that

$$f = f \chi_{D_1} + f \chi_{D_2} - f \chi_{D_1 \cap D_2}$$

is Riemann integrable. It follows from (i) that

$$\int_{D_1 \cup D_2} f = \int_{D_1} f + \int_{D_2} f - \underbrace{\int_{D_1 \cap D_2} f}_{=0}.$$

(v): Since  $M - f(x) \geq 0$  holds for all  $x \in D$ , we have by (ii) that

$$0 \leq \int_D (M - f) = M \int_D 1 - \int_D f = M \mu(D) - \int_D f.$$

Similarly, one proves that  $m \mu(D) \leq \int_D f$ .

(vi): Without loss of generality, suppose that  $\mu(D) > 0$ . Let

$$m := \inf\{f(x) : x \in D\} \quad \text{and} \quad M := \sup\{f(x) : x \in D\},$$

so that

$$m \leq \frac{\int_D f}{\mu(D)} \leq M.$$

Let  $x_1, x_2 \in D$  be such that  $f(x_1) = m$  and  $f(x_2) = M$ . By the Intermediate Value Theorem, there is  $x_0 \in D$  such that  $f(x_0) = \frac{\int_D f}{\mu(D)}$ .  $\square$

### Exercises

1. Let  $I$  be a compact interval, and let  $f = (f_1, \dots, f_M) : I \rightarrow \mathbb{R}^M$ . Show that  $f$  is Riemann integrable if and only if  $f_j : I \rightarrow \mathbb{R}$  is Riemann integrable for each  $j = 1, \dots, M$  and that, in this case,

$$\int_I f = \left( \int_I f_1, \dots, \int_I f_M \right)$$

holds.

2. Let  $I \subset \mathbb{R}^N$  be a compact interval, and let  $f : I \rightarrow \mathbb{R}^M$  be Riemann integrable. Show that  $f$  is bounded.
3. Let  $\emptyset \neq D \subset \mathbb{R}^N$  have content zero, and let  $f : D \rightarrow \mathbb{R}^M$  be bounded. Show that  $f$  is Riemann-integrable on  $D$  such that

$$\int_D f = 0.$$

4. Let  $\emptyset \neq D \subset \mathbb{R}^N$  be bounded, and let  $f, g : D \rightarrow \mathbb{R}$  be Riemann-integrable. Show that  $fg : D \rightarrow \mathbb{R}$  is Riemann-integrable.

Do we have

$$\int_D fg = \left( \int_D f \right) \left( \int_D g \right)?$$

(Hint: First treat the case where  $f = g$ , treat the general case by observing that  $fg = \frac{1}{2}((f+g)^2 - f^2 - g^2)$ .)

5. Determine whether or not the function  $f$  in Exercise 3.4.8 is Riemann integrable on  $[-1, 1]^2$ .



6. Let  $\emptyset \neq U \subset \mathbb{R}^N$  be open with content, and let  $f: U \rightarrow [0, \infty)$  be bounded and continuous such that  $\int_U f = 0$ . Show that  $f \equiv 0$  on  $U$ .
7. Let  $I \subset \mathbb{R}^N$  be a compact interval. Show that

$$\mathcal{A} := \{A \subset I : A \text{ has content}\}$$

is an *algebra* over  $I$ , i.e.,

- (a)  $\emptyset, I \in \mathcal{A}$ ,
- (b) if  $A \in \mathcal{A}$ , then  $I \setminus A \in \mathcal{A}$ , and
- (c) if  $A_1, \dots, A_n \in \mathcal{A}$ , then  $A_1 \cup \dots \cup A_n \in \mathcal{A}$ .

### 4.3 Evaluation of Integrals in One Variable: A Review

In this section, we review the basic techniques for evaluating Riemann integrals of functions of one variable:

**Theorem 4.3.1.** *Let  $f: [a, b] \rightarrow \mathbb{R}$  be continuous, and let  $F: [a, b] \rightarrow \mathbb{R}$  be defined as*

$$F(x) := \int_a^x f(t) dt$$

for  $x \in [a, b]$ . Then  $F$  is an antiderivative of  $f$ , i.e.,  $F$  is differentiable such that  $F' = f$ .

*Proof.* Let  $x \in [a, b]$ , and let  $h \neq 0$  such that  $x + h \in [a, b]$ . By the Mean Value Theorem of integration, we obtain that

$$F(x + h) - F(x) = \int_x^{x+h} f(t) dt = f(\xi_h)h$$

for some  $\xi_h$  between  $x + h$  and  $x$ . It follows that

$$\frac{F(x + h) - F(x)}{h} = f(\xi_h) \xrightarrow{h \rightarrow 0} f(x)$$

because  $f$  is continuous. □

**Proposition 4.3.2.** *Let  $F_1$  and  $F_2$  be antiderivatives of a function  $f: [a, b] \rightarrow \mathbb{R}$ . Then  $F_1 - F_2$  is constant.*

*Proof.* This is clear because  $(F_1 - F_2)' = f - f = 0$ . □

**Theorem 4.3.3** (Fundamental Theorem of Calculus). *Let  $f: [a, b] \rightarrow \mathbb{R}$  be continuous, and let  $F: [a, b] \rightarrow \mathbb{R}$  be any antiderivative of  $f$ . Then*

$$\int_a^b f(x) dx = F(b) - F(a) =: F(x) \Big|_a^b$$

holds.

*Proof.* By Theorem 4.3.1 and by Proposition 4.3.2, there is  $C \in \mathbb{R}$  such that

$$\int_a^x f(t) dt = F(x) - C$$

for all  $x \in [a, b]$ . Since

$$F(a) - C = \int_a^a f(t) dt = 0,$$

we have  $C = F(a)$  and thus

$$\int_a^b f(t) dt = F(b) - F(a).$$

This proves the claim. □

*Example.* Since  $\frac{d}{dx} \sin x = \cos x$ , it follows that

$$\int_0^\pi \sin x dx = -\cos x \Big|_0^\pi = 2.$$

**Corollary 4.3.4** (Change of Variables). *Let  $\phi: [a, b] \rightarrow \mathbb{R}$  be continuously differentiable, let  $f: [c, d] \rightarrow \mathbb{R}$  be continuous, and suppose that  $\phi([a, b]) \subset [c, d]$ . Then*

$$\int_{\phi(a)}^{\phi(b)} f(x) dx = \int_a^b f(\phi(t))\phi'(t) dt$$

*holds.*

*Proof.* Let  $F$  be an antiderivative of  $f$ . The chain rule yields that

$$(F \circ \phi)' = (f \circ \phi)\phi',$$

so that  $F \circ \phi$  is an antiderivative of  $(f \circ \phi)\phi'$ . By the Fundamental Theorem of Calculus, we thus have

$$\int_{\phi(a)}^{\phi(b)} f(x) dx = F(\phi(b)) - F(\phi(a)) = (F \circ \phi)(b) - (F \circ \phi)(a) = \int_a^b f(\phi(t))\phi'(t) dt$$

as claimed. □

*Examples.*

1. We have

$$\begin{aligned} \int_0^{\sqrt{\pi}} x \sin(x^2) dx &= \frac{1}{2} \int_0^{\sqrt{\pi}} 2x \sin(x^2) dx \\ &= \frac{1}{2} \int_0^\pi \sin u du \\ &= -\frac{1}{2} \cos u \Big|_0^\pi \\ &= \frac{1}{2} + \frac{1}{2} \\ &= 1. \end{aligned}$$

2. We have

$$\int_0^1 \sqrt{1-x^2} dx = \int_0^{\frac{\pi}{2}} \sqrt{1-\sin^2 t} \cos t dt = \int_0^{\frac{\pi}{2}} \sqrt{\cos^2 t} \cos t dt = \int_0^{\frac{\pi}{2}} \cos^2 t dt.$$

**Corollary 4.3.5** (Integration by Parts). *Let  $f, g: [a, b] \rightarrow \mathbb{R}$  be continuously differentiable.*

*Then*

$$\int_a^b f(x)g'(x) dx = f(b)g(b) - f(a)g(a) - \int_a^b f'(x)g(x) dx$$

*holds.*

*Proof.* By the product rule, we have

$$\frac{d}{dx} f(x)g(x) = f(x)g'(x) + f'(x)g(x)$$

for  $x \in [a, b]$ , and the fundamental theorem of calculus yields

$$\begin{aligned} f(b)g(b) - f(a)g(a) &= \int_a^b \frac{d}{dx} f(x)g(x) dx \\ &= \int_a^b (f(x)g'(x) + f'(x)g(x)) dx \\ &= \int_a^b f(x)g'(x) dx + \int_a^b f'(x)g(x) dx \end{aligned}$$

as claimed. □

*Examples.*

1. Note that

$$\begin{aligned} \int_0^{\frac{\pi}{2}} \cos^2 x dx &= -\sin(0)\cos(0) + \sin\left(\frac{\pi}{2}\right)\cos\left(\frac{\pi}{2}\right) + \int_0^{\frac{\pi}{2}} \sin^2 x dx \\ &= \int_0^{\frac{\pi}{2}} \sin^2 x dx \\ &= \int_0^{\frac{\pi}{2}} (1 - \cos^2 x) dx \\ &= \frac{\pi}{2} - \int_0^{\frac{\pi}{2}} \cos^2 x dx, \end{aligned}$$

so that

$$\int_0^{\frac{\pi}{2}} \cos^2 x dx = \frac{\pi}{4}.$$

Combining this with the second example on change of variables, we also obtain that

$$\int_0^1 \sqrt{1-t^2} dt = \int_0^{\frac{\pi}{2}} \cos^2 x dx = \frac{\pi}{4}.$$

2. We have

$$\int_1^x \log t \, dt = \int_1^x 1 \log t \, dt = t \log t \Big|_1^x - \int_1^x t \frac{1}{t} \, dt = x \log x - (x - 1).$$

Hence,

$$(0, \infty) \rightarrow \mathbb{R}, \quad x \mapsto x \log x - x$$

is an antiderivative of the natural logarithm.

## 4.4 Fubini's Theorem

Fubini's Theorem is the first major tool for the actual computation of Riemann integrals in several dimensions (the other one is Change of Variables). It asserts that multi-dimensional Riemann integrals can be computed through iteration of one-dimensional ones:

**Theorem 4.4.1** (Fubini's Theorem). *Let  $I \subset \mathbb{R}^N$  and  $J \subset \mathbb{R}^M$  be compact intervals, and let  $f: I \times J \rightarrow \mathbb{R}^K$  be Riemann integrable such that, for each  $x \in I$ , the integral*

$$F(x) := \int_J f(x, y) \, d\mu_M(y)$$

*exists. Then  $F: I \rightarrow \mathbb{R}^K$  is Riemann integrable such that*

$$\int_I F = \int_{I \times J} f.$$

*Proof.* Let  $\epsilon > 0$ .

Choose a partition  $\mathcal{P}_\epsilon$  of  $I \times J$  such that

$$\left\| S(f, \mathcal{P}) - \int_{I \times J} f \right\| < \frac{\epsilon}{2}$$

for any Riemann sum  $S(f, \mathcal{P})$  of  $f$  corresponding to a partition  $\mathcal{P}$  of  $I \times J$  finer than  $\mathcal{P}_\epsilon$ .

Let  $\mathcal{P}_{\epsilon,x}$  and  $\mathcal{P}_{\epsilon,y}$  be the partitions of  $I$  and  $J$ , respectively, such that  $\mathcal{P}_\epsilon := \mathcal{P}_{\epsilon,x} \times \mathcal{P}_{\epsilon,y}$ . Set  $\mathcal{Q}_\epsilon := \mathcal{P}_{\epsilon,x}$ , and let  $\mathcal{Q}$  be a refinement of  $\mathcal{Q}_\epsilon$  with corresponding subdivision  $(I_\nu)_\nu$  of  $I$ ; pick  $x_\nu \in I_\nu$ . For each  $\nu$ , there is a partition  $\mathcal{R}_{\epsilon,\nu}$  of  $J$  such that, for each refinement  $\mathcal{R}$  of  $\mathcal{R}_{\epsilon,\nu}$  with corresponding subdivision  $(J_\lambda)_\lambda$ , we have

$$\left\| \sum_\lambda f(x_\nu, y_\lambda) \mu_M(J_\lambda) - F(x_\nu) \right\| < \frac{\epsilon}{2\mu_N(I)} \quad (4.2)$$

for any choice of  $y_\lambda \in J_\lambda$ . Let  $\mathcal{R}_\epsilon$  be a common refinement of  $(\mathcal{R}_{\epsilon,\nu})_\nu$  and  $\mathcal{P}_{\epsilon,y}$  with corresponding subdivision  $(J_\lambda)_\lambda$  of  $J$ . Consequently,  $\mathcal{Q} \times \mathcal{R}_\epsilon$  is a refinement of  $\mathcal{P}_\epsilon$  with corresponding subdivision  $(I_\nu \times J_\lambda)_{\nu,\lambda}$  of  $I \times J$ . Picking  $y_\lambda \in J_\lambda$ , we thus have

$$\left\| \sum_{\nu,\lambda} f(x_\nu, y_\lambda) \mu_N(I_\nu) \mu_M(J_\lambda) - \int_{I \times J} f \right\| < \frac{\epsilon}{2}. \quad (4.3)$$

We therefore obtain

$$\begin{aligned}
& \left\| \sum_{\nu} F(x_{\nu}) \mu_N(I_{\nu}) - \int_{I \times J} f \right\| \\
& \leq \left\| \sum_{\nu} F(x_{\nu}) \mu_N(I_{\nu}) - \sum_{\nu, \lambda} f(x_{\nu}, y_{\lambda}) \mu_N(I_{\nu}) \mu_M(J_{\lambda}) \right\| \\
& \quad + \left\| \sum_{\nu, \lambda} f(x_{\nu}, y_{\lambda}) \mu_N(I_{\nu}) \mu_M(J_{\lambda}) - \int_{I \times J} f \right\| \\
& < \left\| \sum_{\nu} F(x_{\nu}) \mu_N(I_{\nu}) - \sum_{\nu, \lambda} f(x_{\nu}, y_{\lambda}) \mu_N(I_{\nu}) \mu_M(J_{\lambda}) \right\| + \frac{\epsilon}{2}, \quad \text{by (4.3),} \\
& \leq \sum_{\nu} \left\| F(x_{\nu}) - \sum_{\lambda} f(x_{\nu}, y_{\lambda}) \mu_M(J_{\lambda}) \right\| \mu_N(I_{\nu}) + \frac{\epsilon}{2} \\
& < \sum_{\nu} \frac{\epsilon}{2 \mu_N(I)} \mu(I_{\nu}) + \frac{\epsilon}{2} \\
& = \frac{\epsilon}{2} + \frac{\epsilon}{2} \\
& = \epsilon.
\end{aligned}$$

Since this holds for each refinement  $\mathcal{Q}$  of  $\mathcal{Q}_{\epsilon}$ , and for any choice of  $x_{\nu} \in I_{\nu}$ , we obtain that  $F$  is Riemann integrable such that

$$\int_I F = \int_{I \times J} f,$$

as claimed. □

*Examples.*

1. Let

$$f: [0, 1] \times [0, 1] \rightarrow \mathbb{R}, \quad (x, y) \mapsto xy.$$

We obtain

$$\begin{aligned}
\int_{[0,1] \times [0,1]} f &= \int_0^1 \left( \int_0^1 xy \, dy \right) dx \\
&= \int_0^1 x \left( \int_0^1 y \, dy \right) dx \\
&= \int_0^1 x \left( \frac{y^2}{2} \Big|_0^1 \right) dx \\
&= \frac{1}{2} \int_0^1 x \, dx \\
&= \frac{1}{4}.
\end{aligned}$$

2. Let

$$f: [0, 1] \times [0, 1] \rightarrow \mathbb{R}, \quad (x, y) \mapsto y^3 e^{xy^2}.$$

Then Fubini's Theorem yields

$$\int_{[0,1] \times [0,1]} f = \int_0^1 \left( \int_0^1 y^3 e^{xy^2} dy \right) dx = ?.$$

Changing the order of integration, however, we obtain

$$\begin{aligned} \int_{[0,1] \times [0,1]} f &= \int_0^1 \left( \int_0^1 y^3 e^{xy^2} dx \right) dy \\ &= \int_0^1 y e^{xy^2} \Big|_0^1 dy \\ &= \int_0^1 (y e^{y^2} - y) dy \\ &= \frac{1}{2} e^{y^2} - \frac{y^2}{2} \Big|_0^1 \\ &= \frac{1}{2} e - \frac{1}{2} - \frac{1}{2} \\ &= \frac{1}{2} e - 1. \end{aligned}$$

The following corollary is a straightforward specialization of Fubini's Theorem applied twice (in each variable).

**Corollary 4.4.2.** *Let  $I = [a, b] \times [c, d]$ , let  $f: I \rightarrow \mathbb{R}$  be Riemann integrable, and suppose that:*

- (a) *for each  $x \in [a, b]$ , the integral  $\int_c^d f(x, y) dy$  exists;*
- (b) *for each  $y \in [c, d]$ , the integral  $\int_a^b f(x, y) dx$  exists.*

Then

$$\int_a^b \left( \int_c^d f(x, y) dy \right) dx = \int_I f = \int_c^d \left( \int_a^b f(x, y) dx \right) dy$$

holds.

Similarly straightforward is the next corollary:

**Corollary 4.4.3.** *Let  $I = [a, b] \times [c, d]$ , and let  $f: I \rightarrow \mathbb{R}$  be bounded such that the set  $D_0$  of its discontinuity points has content zero and satisfies  $\mu_1(\{y \in [c, d] : (x, y) \in D_0\}) = 0$  for each  $x \in [a, b]$ . Then  $f$  is Riemann integrable such that*

$$\int_I f = \int_a^b \left( \int_c^d f(x, y) dy \right) dx.$$

Another, less straightforward consequence is:

**Corollary 4.4.4.** *Let  $\phi, \psi: [a, b] \rightarrow \mathbb{R}$  be continuous such that  $\phi \leq \psi$ , let*

$$D := \{(x, y) \in \mathbb{R}^2 : x \in [a, b], \phi(x) \leq y \leq \psi(x)\},$$

and let  $f: D \rightarrow \mathbb{R}$  be bounded such that the set  $D_0$  of its discontinuity points has content zero and satisfies  $\mu_1(\{y \in \mathbb{R} : (x, y) \in D_0\}) = 0$  for each  $x \in \mathbb{R}$ . Then  $f$  is Riemann integrable such that

$$\int_D f = \int_a^b \left( \int_{\phi(x)}^{\psi(x)} f(x, y) dy \right) dx.$$

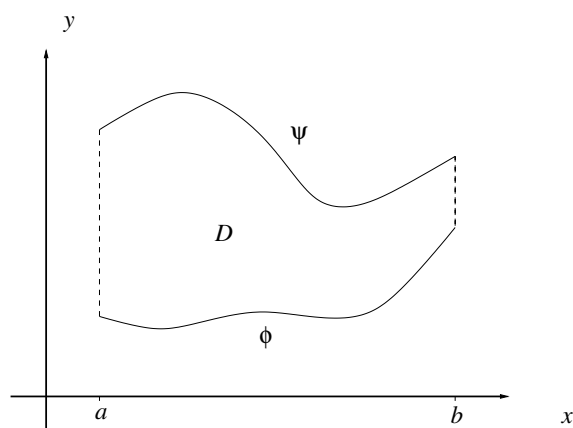

Figure 4.5: The domain  $D$  in Corollary 4.4.4

*Proof.* Choose  $c, d \in \mathbb{R}$  such that  $D \subset [a, b] \times [c, d]$  and extend  $f$  as  $\tilde{f}$  to  $[a, b] \times [c, d]$  by setting it equal to zero outside  $D$ . It is not difficult to see that the set of discontinuity points of  $\tilde{f}$  is contained in  $D_0 \cup \partial D$  and thus has content zero. Hence, Fubini's theorem is applicable and yields

$$\int_D f = \int_{[a,b] \times [c,d]} \tilde{f} = \int_a^b \left( \int_c^d \tilde{f}(x, y) dy \right) dx = \int_a^b \left( \int_{\phi(x)}^{\psi(x)} f(x, y) dy \right) dx.$$

This completes the proof. □

*Example.* Let

$$D := \{(x, y) \in \mathbb{R}^2 : 1 \leq x \leq 3, x^2 \leq y \leq x^2 + 1\}.$$

It follows that

$$\mu(D) = \int_D 1 = \int_1^3 \left( \int_{x^2}^{x^2+1} 1 dy \right) dx = \int_1^3 1 dx = 2.$$

**Corollary 4.4.5** (Cavalieri's Principle). *Let  $N \geq 2$ , and suppose that  $S, T \subset \mathbb{R}^N$  have content. For each  $x \in \mathbb{R}$ , let*

$$S_x := \{(x_1, \dots, x_{N-1}) \in \mathbb{R}^{N-1} : (x, x_1, \dots, x_{N-1}) \in S\}$$

and

$$T_x := \{(x_1, \dots, x_{N-1}) \in \mathbb{R}^{N-1} : (x, x_1, \dots, x_{N-1}) \in T\},$$

and suppose that  $S_x$  and  $T_x$  have content with  $\mu_{N-1}(S_x) = \mu_{N-1}(T_x)$  for each  $x \in \mathbb{R}$ . Then  $\mu_N(S) = \mu_N(T)$  holds.

*Proof.* Let  $I \subset \mathbb{R}$  and  $J \subset \mathbb{R}^{N-1}$  be compact intervals such that  $S, T \subset I \times J$ , and note that

$$\begin{aligned} \mu_N(S) &= \int_{I \times J} \chi_S \\ &= \int_I \left( \int_J \chi_S(x, x_1, \dots, x_{N-1}) d\mu_{N-1}(x_1, \dots, x_{N-1}) \right) dx \\ &= \int_I \left( \int_J \chi_{S_x} \right) \\ &= \int_I \mu_{N-1}(S_x) \\ &= \int_I \mu_{N-1}(T_x) \\ &= \int_I \left( \int_J \chi_{T_x} \right) \\ &= \int_I \left( \int_J \chi_T(x, x_1, \dots, x_{N-1}) d\mu_{N-1}(x_1, \dots, x_{N-1}) \right) dx \\ &= \int_{I \times J} \chi_T \\ &= \mu_N(T). \end{aligned}$$

This completes the proof. □

*Example.* Let  $r > 0$ , and let

$$T := \{(x, y, z) \in \mathbb{R}^3 : z \geq 0, x^2 + y^2 + z^2 \leq r^2\},$$

i.e., the half of  $B_r[(0, 0, 0)]$  lying above the  $xy$ -plane, and

$$S := \{(x, y, z) \in \mathbb{R}^3 : z \geq 0, x^2 + y^2 \leq r^2, 0 \leq z^2 \leq x^2 + y^2\},$$

i.e., the part of the cylinder standing perpendicularly on the  $xy$ -plane with base  $B_r[(0, 0)]$  between the  $xy$ -plane and the plane  $z = r$  with the cone with base  $B_r[(0, 0, r)]$  and apex  $(0, 0, 0)$  removed.

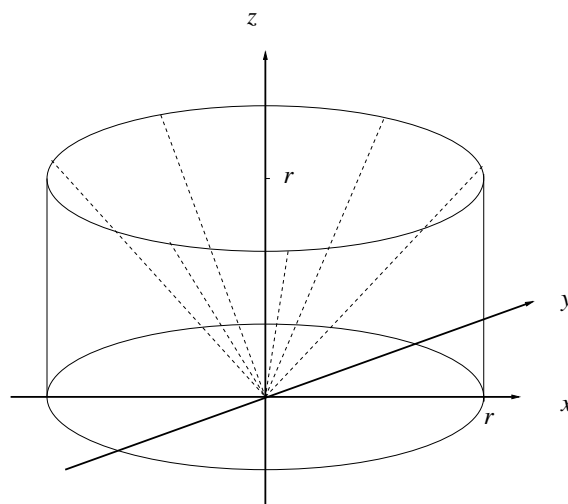

Figure 4.6: Sketch of  $S$ 

For  $z \notin [0, r]$ , it is obvious that  $T_z = S_z = \emptyset$ , so let  $z \in [0, r]$ . Then

$$T_z = \{(x, y) \in \mathbb{R}^2 : x^2 + y^2 \leq r^2 - z^2\} = B_{\sqrt{r^2 - z^2}}[(0, 0)],$$

and

$$S_z = \{(x, y) \in \mathbb{R}^2 : z^2 \leq x^2 + y^2 \leq r^2\} = B_r[(0, 0)] \setminus B_z((0, 0)),$$

so that

$$\mu_2(T_z) = \pi(r^2 - z^2) = \pi r^2 - \pi z^2 = \mu_2(S_z).$$

From Cavalieri's Principle we conclude that  $\mu_3(T) = \mu_3(S)$ . An inspection of the proof of Cavalieri's Principle shows that

$$\mu_2(T) = \int_0^r \mu(T_z) dz = \pi \int_0^r r^2 - z^2 dz = \pi r^2 z - \frac{z^3}{3} \Big|_0^r = \frac{2\pi r^3}{3},$$

so that  $\mu_3(B_r[(0, 0, 0)]) = \frac{4\pi r^3}{3}$ .

### Exercises

1. Let

$$f: [0, 1] \times [0, 1] \rightarrow \mathbb{R}, \quad (x, y) \mapsto xy.$$

Evaluate  $\int_{[0,1] \times [0,1]} f$  using only the definition of the Riemann integral, i.e., in particular, without use of Fubini's Theorem.

2. Calculate  $\int_I f$  for the following  $I$  and  $f$ :

(i)  $I = [0, 2] \times [3, 4]$ ,  $f(x, y) = 2x + 3y$ ;

- (ii)  $I = [0, \frac{\pi}{2}] \times [0, \frac{\pi}{2}]$ ,  $f(x, y) = \sin(x + y)$ ;  
 (iii)  $I = [1, 2] \times [2, 3] \times [0, 2]$ ,  $f(x, y, z) = \frac{2z}{(x+y)^2}$ .

3. Let  $a < b$ , let  $f: [a, b] \rightarrow [0, \infty)$  be continuous, and let

$$D := \{(x, y) : x \in [a, b], y \in [0, f(x)]\}.$$

Show that  $D$  has content and that

$$\mu(D) = \int_a^b f(x) dx.$$

4. Let

$$D := \{(x, y) \in \mathbb{R} : x, y \geq 0, x^2 + y^2 \leq 1\},$$

and let

$$f: D \rightarrow \mathbb{R}, \quad (x, y) \mapsto \frac{4y^3}{(x+1)^2}$$

Evaluate  $\int_D f$ .

5. Define

$$f: [0, 1]^3 \rightarrow \mathbb{R}, \quad (x, y, z) \mapsto \begin{cases} xy, & z \leq xy, \\ z, & z \geq xy. \end{cases}$$

Evaluate  $\int_{[0,1]^3} f$ .

6. Let  $I \subset \mathbb{R}^N$  and  $J \subset \mathbb{R}^M$  be compact intervals, let  $f: I \rightarrow \mathbb{R}$  and  $g: J \rightarrow \mathbb{R}$  be continuous, and define

$$f \otimes g: I \times J \rightarrow \mathbb{R}, \quad (x, y) \mapsto f(x)g(y).$$

7. Let  $f: [a, b] \rightarrow (0, \infty)$  be continuous. Show that

$$\left( \int_a^b f(x) dx \right) \left( \int_a^b \frac{1}{f(x)} dx \right) \geq (b-a)^2.$$

(*Hint:* Apply Fubini's Theorem to  $[a, b]^2 \ni (x, y) \mapsto \frac{f(x)}{f(y)}$ .)

8. Define  $f: [0, 1] \times [0, 1] \rightarrow \mathbb{R}$  by letting

$$f(x, y) = \begin{cases} 2^{2n}, & \text{if } (x, y) \in [2^{-n}, 2^{-n+1}] \times [2^{-n}, 2^{-n+1}] \text{ for some } n \in \mathbb{N}, \\ -2^{2n+1}, & \text{if } (x, y) \in [2^{-n-1}, 2^{-n}] \times [2^{-n}, 2^{-n+1}] \text{ for some } n \in \mathbb{N}, \\ 0, & \text{otherwise.} \end{cases}$$

Show that the iterated integrals

$$\int_0^1 \left( \int_0^1 f(x, y) dy \right) dx \quad \text{and} \quad \int_0^1 \left( \int_0^1 f(x, y) dx \right) dy$$

both exist, but that

$$\int_0^1 \left( \int_0^1 f(x, y) dy \right) dx \neq \int_0^1 \left( \int_0^1 f(x, y) dx \right) dy.$$

Why doesn't this contradict Fubini's Theorem?

## 4.5 Integration in Polar, Spherical, and Cylindrical Coordinates

In the last example of the previous section, we used Fubini's Theorem to determine the volume of a sphere in  $\mathbb{R}^3$ —by making recourse to the area of a disc in  $\mathbb{R}^2$ . But how can we rigorously compute the area of a disc with given diameter in  $\mathbb{R}^2$ ? We will answer this question in this section.

The second main tool for the calculation of multi-dimensional integrals is the multi-dimensional Change of Variables formula:

**Theorem 4.5.1** (Change of Variables). *Let  $\emptyset \neq U \subset \mathbb{R}^N$  be open, let  $\emptyset \neq K \subset U$  be compact with content, let  $\phi: U \rightarrow \mathbb{R}^N$  be continuously partially differentiable, and suppose that there is a set  $Z \subset K$  with content zero such that  $\phi|_{K \setminus Z}$  is injective and  $\det J_\phi(x) \neq 0$  for all  $x \in K \setminus Z$ . Then  $\phi(K)$  has content and*

$$\int_{\phi(K)} f = \int_K (f \circ \phi) |\det J_\phi|$$

holds for all continuous functions  $f: \phi(U) \rightarrow \mathbb{R}^M$ .

*Proof.* Postponed, but not skipped! □

*Examples.*

1. Let  $a, b, c > 0$  and let

$$E := \left\{ (x, y, z) \in \mathbb{R}^3 : \frac{x^2}{a^2} + \frac{y^2}{b^2} + \frac{z^2}{c^2} \leq 1 \right\}.$$

What is the content of  $E$ ?

Let

$$\phi: \mathbb{R}^3 \rightarrow \mathbb{R}^3, \quad (r, \theta, \varphi) \mapsto (ar \sin \theta \cos \varphi, br \sin \theta \sin \varphi, cr \cos \theta),$$

and let

$$K := [0, 1] \times [0, \pi] \times [0, 2\pi],$$

so that  $E = \phi(K)$ . Of course,  $\phi$  is not injective on  $K$ .

Set

$$Z := (\{0\} \times [0, \pi] \times [0, 2\pi]) \cup ([0, 1] \times \{0, \pi\} \times [0, 2\pi]) \cup ([0, 1] \times [0, \pi] \times \{0\}),$$

so that

$$K \setminus Z = (0, 1] \times (0, \pi) \times (0, 2\pi].$$

It is clear that  $\mu_3(Z) = 0$ .

We *claim* that  $\phi|_{K \setminus Z}$  is injective. To see this, let  $(r_1, \theta_1, \varphi_1), (r_2, \theta_2, \varphi_2) \in K \setminus Z$  be such that  $\phi(r_1, \theta_1, \varphi_1) = \phi(r_2, \theta_2, \varphi_2)$ . As  $a, b, c > 0$ , this means that

$$\begin{aligned} r_1 \sin \theta_1 \cos \varphi_1 &= r_2 \sin \theta_2 \cos \varphi_2, \\ r_1 \sin \theta_1 \sin \varphi_1 &= r_2 \sin \theta_2 \sin \varphi_2, \\ r_1 \cos \theta_1 &= r_2 \cos \theta_2. \end{aligned}$$

It follows that

$$\begin{aligned} r_1^2 &= r_1^2(\sin^2 \theta_1(\cos^2 \varphi_1 + \sin^2 \varphi_1) + \cos^2 \theta_1) \\ &= r_1^2 \sin^2 \theta_1 \cos^2 \varphi_1 + r_1^2 \sin^2 \theta_1 \sin^2 \varphi_1 + r_1^2 \cos^2 \theta_1 \\ &= r_2^2 \sin^2 \theta_2 \cos^2 \varphi_2 + r_2^2 \sin^2 \theta_2 \sin^2 \varphi_2 + r_2^2 \cos^2 \theta_2 \\ &= r_2^2(\sin^2 \theta_2(\cos^2 \varphi_2 + \sin^2 \varphi_2) + \cos^2 \theta_2) \\ &= r_2^2, \end{aligned}$$

so that  $r_1 = r_2$ . As  $r_1, r_2 > 0$ , this means that

$$\begin{aligned} \sin \theta_1 \cos \varphi_1 &= \sin \theta_2 \cos \varphi_2, \\ \sin \theta_1 \sin \varphi_1 &= \sin \theta_2 \sin \varphi_2, \\ \cos \theta_1 &= \cos \theta_2. \end{aligned}$$

Now,  $\cos$  is injective on  $[0, \pi]$ , so that  $\theta_1 = \theta_2$  and hence  $\sin \theta_1 = \sin \theta_2$ . As  $\sin$  is non-zero on  $(0, \pi)$ , we conclude that  $\cos \varphi_1 = \cos \varphi_2$  and  $\sin \varphi_1 = \sin \varphi_2$ . Since

$$(0, 2\pi] \rightarrow \mathbb{R}^2, \quad \varphi \mapsto (\cos \varphi, \sin \varphi)$$

is injective, it follows that  $\varphi_1 = \varphi_2$  as well.

For  $(r, \theta, \varphi) \in K$ , we have

$$J_\phi(r, \theta, \varphi) = \begin{bmatrix} a \sin \theta \cos \varphi, & ar \cos \theta \cos \varphi, & -ar \sin \theta \sin \varphi \\ b \sin \theta \sin \varphi, & br \cos \theta \sin \varphi, & br \sin \theta \cos \varphi \\ c \cos \theta, & -cr \sin \theta, & 0 \end{bmatrix},$$

and thus

$$\begin{aligned}
 \det J_\phi(r, \theta, \varphi) &= abc \det \begin{bmatrix} \sin \theta \cos \varphi, & r \cos \theta \cos \varphi, & -r \sin \theta \sin \varphi \\ \sin \theta \sin \varphi, & r \cos \theta \sin \varphi, & r \sin \theta \cos \varphi \\ \cos \theta, & -r \sin \theta, & 0 \end{bmatrix} \\
 &= abc \left( \cos \theta \begin{bmatrix} r \cos \theta \cos \varphi, & -r \sin \theta \sin \varphi \\ r \cos \theta \sin \varphi, & r \sin \theta \cos \varphi \end{bmatrix} \right. \\
 &\quad \left. r \sin \theta \begin{bmatrix} \sin \theta \cos \varphi, & -r \sin \theta \sin \varphi \\ \sin \theta \sin \varphi, & r \sin \theta \cos \varphi \end{bmatrix} \right) \\
 &= abc r^2 (\cos \theta (\cos \theta \sin \theta \cos^2 \varphi + \cos \theta \sin \theta \sin^2 \varphi) \\
 &\quad + \sin \theta (\sin^2 \theta \cos^2 \varphi + \sin^2 \theta \sin^2 \varphi)) \\
 &= abc r^2 \sin \theta (\cos^2 \theta + \sin^2 \theta) \\
 &= abc r^2 \sin \theta,
 \end{aligned}$$

so that, particular,  $\det J_\phi(r, \theta, \varphi) \neq 0$  if  $(r, \theta, \varphi) \notin Z$ .

Therefore, Change of Variables applies, and we obtain

$$\begin{aligned}
 \mu(E) &= \int_E 1 \\
 &= \int_K 1 |\det J_\phi| \\
 &= abc \int_0^1 \left( \int_0^\pi \left( \int_0^{2\pi} r^2 \sin \theta d\varphi \right) d\theta \right) dr \\
 &= 2\pi abc \int_0^1 r^2 \left( \int_0^\pi \sin \theta d\theta \right) dr \\
 &= 2\pi abc \int_0^1 r^2 \cos \theta \Big|_0^\pi dr \\
 &= 4\pi abc \int_0^1 r^2 dr \\
 &= 4\pi abc \frac{r^3}{3} \Big|_0^1 \\
 &= \frac{4\pi}{3} abc.
 \end{aligned}$$

2. Let

$$f: \mathbb{R}^2 \rightarrow \mathbb{R}, \quad (x, y) \mapsto \frac{1}{x^2 + y^2 + 1}.$$

Find  $\int_{B_1[(0,0)]} f$ .

Use *polar coordinates*, i.e., let

$$\phi: \mathbb{R}^2 \rightarrow \mathbb{R}^2, \quad (r, \theta) \mapsto (r \cos \theta, r \sin \theta).$$

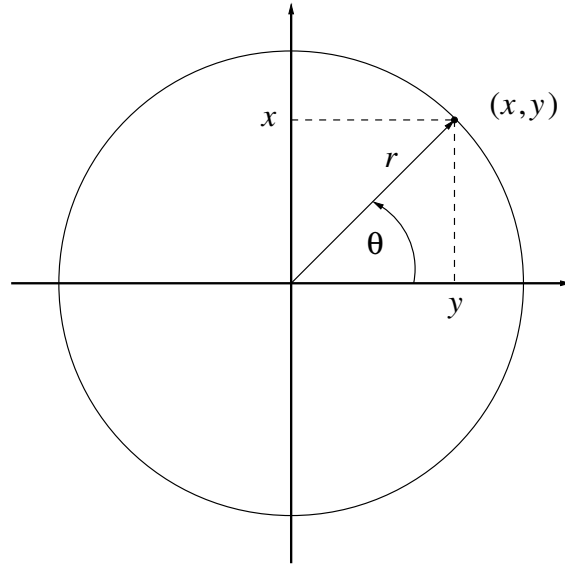

Figure 4.7: Polar coordinates

It follows that  $B_1[(0,0)] = \phi(K)$ , where  $K = [0, 1] \times [0, 2\pi]$ . We have

$$J_\phi(r, \theta) = \begin{bmatrix} \cos \theta & -r \sin \theta \\ \sin \theta & r \cos \theta \end{bmatrix}$$

and thus

$$\det J_\phi(r, \theta) = r.$$

Set

$$Z := (\{0\} \times [0, 2\pi]) \cup ([0, 1] \times \{0\}),$$

so that  $Z$  has content zero,  $\phi|_{K \setminus Z}$  is injective, and  $\det J_\phi$  is non-zero on  $K \setminus Z$ .

Change of Variables then yields

$$\begin{aligned} \int_{B_1[(0,0)]} f &= \int_K \frac{r}{r^2 + 1} \\ &= \int_0^1 \left( \int_0^{2\pi} \frac{r}{r^2 + 1} d\theta \right) dr \\ &= 2\pi \int_0^1 \frac{r}{r^2 + 1} dr \\ &= \pi \int_0^1 \frac{2r}{r^2 + 1} dr \\ &= \pi \int_1^2 \frac{1}{s} ds \\ &= \pi \log s \Big|_1^2 \\ &= \pi \log 2. \end{aligned}$$

3. Let

$$f: \mathbb{R}^3 \rightarrow \mathbb{R}, \quad (x, y, z) \rightarrow \sqrt{x^2 + y^2 + z^2},$$

and let  $R > 0$ .

Find  $\int_{B_R[(0,0,0)]} f$ .

Use *spherical coordinates*, i.e., let

$$\phi: \mathbb{R}^3 \rightarrow \mathbb{R}^3, \quad (r, \theta, \varphi) \mapsto (r \sin \theta \cos \varphi, r \sin \theta \sin \varphi, r \cos \theta),$$

so that

$$\det J_\phi(r, \theta, \varphi) = r^2 \sin \theta.$$

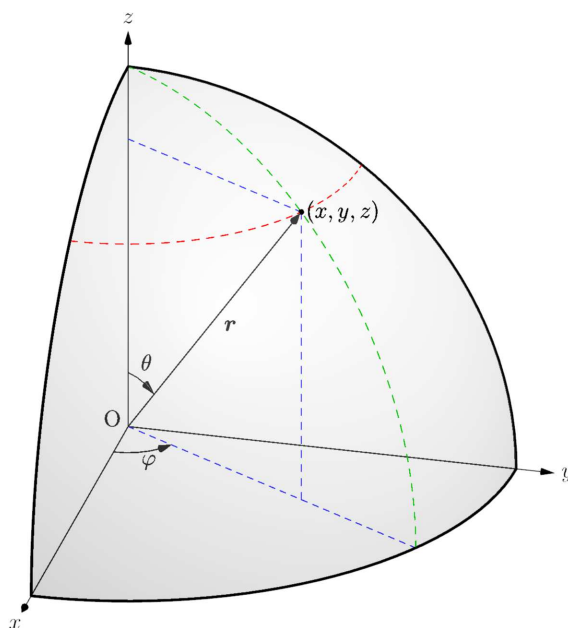

Figure 4.8: Spherical coordinates

It is clear that  $B_R[(0, 0, 0)] = \phi(K)$ , where  $K = [0, R] \times [0, \pi] \times [0, 2\pi]$ . Define  $Z$  as

in the first example. By Change of Variables, we thus have

$$\begin{aligned}
 \int_{B_R[(0,0,0)]} f &= \int_K r^3 \sin \theta \\
 &= \int_0^R \left( \int_0^\pi \left( \int_0^{2\pi} r^3 \sin \theta \, d\sigma \right) d\theta \right) dr \\
 &= 2\pi \int_0^R \left( r^3 \int_0^\pi \cos \theta \, d\theta \right) dr \\
 &= 4\pi \int_0^R r^3 \, dr \\
 &= 4\pi \frac{r^4}{4} \Big|_0^R \\
 &= \pi R^4.
 \end{aligned}$$

4. Let

$$D := \{(x, y, z) \in \mathbb{R}^3 : x, y \geq 0, 1 \leq z \leq x^2 + y^2 \leq e^2\},$$

and let

$$f: D \rightarrow \mathbb{R}, \quad (x, y, z) \mapsto \frac{1}{(x^2 + y^2)z}.$$

Compute  $\int_D f$ .

Use *cylindrical coordinates*, i.e., let

$$\phi: \mathbb{R}^3 \rightarrow \mathbb{R}^3, \quad (r, \theta, z) \mapsto (r \cos \theta, r \sin \theta, z),$$

so that

$$J_\phi(r, \theta, z) = \begin{bmatrix} \cos \theta, & -r \sin \theta, & 0 \\ \sin \theta, & r \cos \theta, & 0 \\ 0, & 0, & 1 \end{bmatrix}$$

and

$$\det J_\phi(r, \theta, z) = r.$$



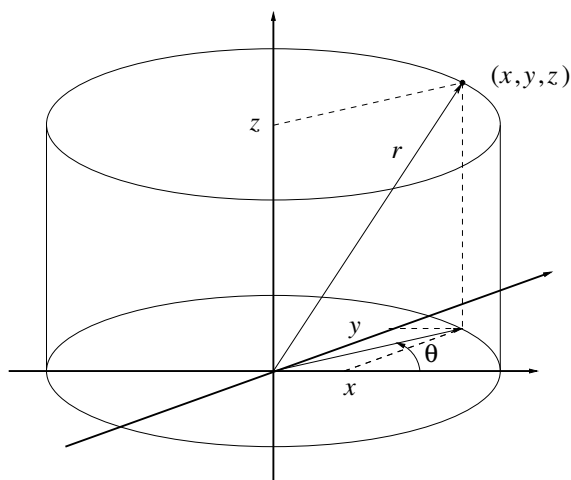

Figure 4.9: Cylindrical coordinates

It follows that  $D = \phi(K)$ , where

$$K := \left\{ (r, \theta, z) : r \in [1, e], \theta \in \left[0, \frac{\pi}{2}\right], z \in [1, r^2] \right\}.$$

It is clear that  $\phi$  is injective on  $K$  and that  $\det J_\phi$  doesn't vanish there. We thus obtain

$$\begin{aligned} \int_D f &= \int_K \frac{r}{r^2 z} \\ &= \int_1^e \left( \int_0^{\frac{\pi}{2}} \left( \int_1^{r^2} \frac{1}{r z} dz \right) d\theta \right) dr \\ &= \frac{\pi}{2} \int_1^e \left( \frac{1}{r} \int_1^{r^2} \frac{1}{z} dz \right) dr \\ &= \frac{\pi}{2} \int_1^e \frac{2 \log r}{r} dr \\ &= \pi \int_0^1 s ds \\ &= \frac{\pi}{2}. \end{aligned}$$

5. Let  $R > 0$ , and let

$$C := \{(x, y, z) \in \mathbb{R}^3 : x^2 + y^2 \leq R^2\}$$

and

$$B := \{(x, y, z) \in \mathbb{R}^3 : x^2 + y^2 + z^2 \leq 4R^2\}.$$

Find  $\mu(C \cap B)$ .

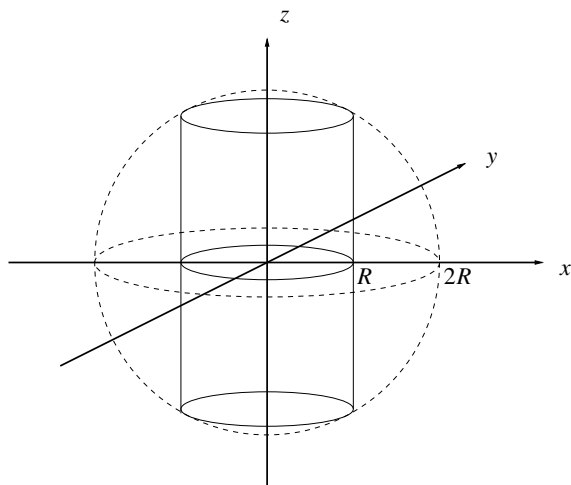

Figure 4.10: Intersection of ball and cylinder

Note that

$$\mu(C \cap B) = 2(\mu(D_1) + \mu(D_2)),$$

where

$$D_1 := \left\{ (x, y, z) \in \mathbb{R}^3 : x^2 + y^2 + z^2 \leq 4R^2, z \geq \sqrt{3(x^2 + y^2)} \right\}$$

and

$$D_2 := \left\{ (x, y, z) \in \mathbb{R}^3 : x^2 + y^2 \leq R^2, 0 \leq z \leq \sqrt{3(x^2 + y^2)} \right\}.$$

Use spherical coordinates to compute  $\mu(D_1)$ .

Note that  $D_1 = \phi(K_1)$ , where

$$K_1 = [0, 2R] \times \left[ \frac{\pi}{3}, \frac{\pi}{2} \right] \times [0, 2\pi].$$

We obtain

$$\begin{aligned} \mu(D_1) &= \int_{K_1} r^2 \cos \theta \\ &= \int_0^{2R} \left( \int_{\frac{\pi}{3}}^{\frac{\pi}{2}} \left( \int_0^{2\pi} r^2 \cos \theta \, d\sigma \right) d\theta \right) dr \\ &= 2\pi \int_0^{2R} \left( r^2 \int_{\frac{\pi}{3}}^{\frac{\pi}{2}} \cos \theta \, d\theta \right) dr \\ &= 2\pi \int_0^{2R} r^2 \left( \sin \left( \frac{\pi}{2} \right) - \sin \left( \frac{\pi}{3} \right) \right) dr \\ &= 2\pi \left( 1 - \frac{\sqrt{3}}{2} \right) \int_0^{2R} r^2 \, dr \\ &= \frac{8R^3}{3} \pi (2 - \sqrt{3}). \end{aligned}$$

Use cylindrical coordinates to compute  $\mu(D_2)$ , and note that  $D_2 = \phi(K_2)$ , where

$$K_2 = \left\{ (r, \theta, z) : r \in [0, R], \theta \in [0, 2\pi], z \in [0, \sqrt{3}r] \right\}.$$

We obtain

$$\begin{aligned} \mu(D_2) &= \int_{K_2} r \\ &= \int_0^R \left( \int_0^{2\pi} \left( \int_0^{\sqrt{3}r} r \, dz \right) d\theta \right) dr \\ &= 2\pi\sqrt{3} \int_0^R r^2 \, dr \\ &= \frac{2\sqrt{3}R^3}{3}\pi. \end{aligned}$$

All in all, we have

$$\begin{aligned} \mu(B \cap C) &= 2(\mu(D_1) + \mu(D_2)) \\ &= \frac{16R^3}{3}\pi(2 - \sqrt{3}) + \frac{4\sqrt{3}R^3}{3}\pi \\ &= \frac{32R^3}{3}\pi - \frac{16\sqrt{3}R^3}{3}\pi + \frac{4\sqrt{3}R^3}{3}\pi \\ &= \left( \frac{32}{3} - 4\sqrt{3} \right) \pi R^3. \end{aligned}$$

### Exercises

1. Let  $a, b > 0$ . Determine the area of the ellipse

$$E := \left\{ (x, y) \in \mathbb{R}^2 : \frac{x^2}{a^2} + \frac{y^2}{b^2} \leq 1 \right\}.$$

2. Let

$$D := \{(x, y, z) \in \mathbb{R}^3 : x^2 + y^2 + z^2 \leq 4, x^2 + y^2 \geq 1, z \geq 0\}.$$

Determine  $\mu_3(D)$ .

3. Let  $D \subset \mathbb{R}^3$  be the region in the first octant, i.e., with  $x, y, z \geq 0$ , which is bounded by the cylinder given by  $x^2 + y^2 = 16$  and the plane given by  $z = 3$ . Evaluate  $\int_D xyz$ .

4. Let  $R > 0$ , and define, for  $0 < \rho < R$ ,

$$A_{\rho, R} := \{(x, y, z) \in \mathbb{R}^3 : \rho^2 \leq x^2 + y^2 + z^2 \leq R^2\}.$$

Determine

$$\lim_{\rho \rightarrow 0} \int_{A_{\rho, R}} \frac{1}{\sqrt{x^2 + y^2 + z^2}}.$$

5. Let  $D$  in spherical coordinates be given as the solid lying between the spheres given by  $r = 2$  and  $r = 4$ , above the  $xy$ -plane and below the cone given by the angle  $\theta = \frac{\pi}{6}$ . Evaluate the integral  $\int_D xyz$ .
6. Let  $D \subset \mathbb{R}^2$  be the trapeze with vertices  $(1, 0)$ ,  $(2, 0)$ ,  $(0, -2)$ , and  $(0, -1)$ . Evaluate  $\int_D \exp\left(\frac{x+y}{x-y}\right)$ . (*Hint*: Consider

$$\phi: \mathbb{R}^2 \rightarrow \mathbb{R}^2, \quad (u, v) \mapsto \left(\frac{1}{2}(u+v), \frac{1}{2}(u-v)\right)$$

and apply Change of Variables.)

## Chapter 5

# Properties of $\mathcal{C}^1$ -Functions and Applications

### 5.1 Local Properties of $\mathcal{C}^1$ -Functions

In this section, we study “local” properties of certain functions, i.e., properties that hold if the function is restricted to certain subsets of its domain, but not necessarily on the whole domain.

We start this section with introducing some shorthand notation:

**Definition 5.1.1.** Let  $\emptyset \neq U \subset \mathbb{R}^N$  be open. We call  $f: U \rightarrow \mathbb{R}^M$  to be:

- (a) of class  $\mathcal{C}^0$ —in symbols:  $f \in \mathcal{C}^0(U, \mathbb{R}^M)$ —if  $f$  is continuous;
- (b) of class  $\mathcal{C}^p$  with  $p \in \mathbb{N}$ —in symbols:  $f \in \mathcal{C}^p(U, \mathbb{R}^M)$ —if  $f$  is  $p$  times continuously partially differentiable, i.e., all partial derivatives of  $f$  up to order  $p$  exist on  $U$  and are continuous.

Our first local property is the following:

**Definition 5.1.2.** Let  $\emptyset \neq D \subset \mathbb{R}^N$ , and let  $f: D \rightarrow \mathbb{R}^M$ . Then  $f$  is *locally injective* at  $x_0 \in D$  if there exists a neighborhood  $U$  of  $x_0$  such that  $f$  is injective on  $U \cap D$ . If  $f$  is locally injective at each point of  $D$ , we simply call  $f$  *locally injective* on  $D$ .

Trivially, every injective function is locally injective. But what about the converse?

**Lemma 5.1.3.** Let  $\emptyset \neq U \subset \mathbb{R}^N$  be open, and let  $f \in \mathcal{C}^1(U, \mathbb{R}^N)$  be such that  $\det J_f(x_0) \neq 0$  for some  $x_0 \in U$ . Then  $f$  is locally injective at  $x_0$ .

*Proof.* Choose  $\epsilon > 0$  such that  $B_\epsilon(x_0) \subset U$  and

$$\det \begin{bmatrix} \frac{\partial f_1}{\partial x_1}(x^{(1)}) & \cdots & \frac{\partial f_1}{\partial x_N}(x^{(1)}) \\ \vdots & \ddots & \vdots \\ \frac{\partial f_N}{\partial x_1}(x^{(N)}) & \cdots & \frac{\partial f_N}{\partial x_N}(x^{(N)}) \end{bmatrix} \neq 0$$

for all  $x^{(1)}, \dots, x^{(N)} \in B_\epsilon(x_0)$ .

Choose  $x, y \in B_\epsilon(x_0)$  such that  $f(x) = f(y)$ , and let  $\xi := y - x$ . By Taylor's theorem, there exists, for each  $j = 1, \dots, N$ , a number  $\theta_j \in [0, 1]$  such that

$$f_j(\underbrace{x + \xi}_{=y}) = f_j(x) + \sum_{k=1}^N \frac{\partial f_j}{\partial x_k}(x + \theta_j \xi) \xi_k = f_j(x).$$

It follows that

$$\sum_{k=1}^N \frac{\partial f_j}{\partial x_k}(x + \theta_j \xi) \xi_k = 0$$

for  $j = 1, \dots, N$ . Let

$$A := \begin{bmatrix} \frac{\partial f_1}{\partial x_1}(x + \theta_1 \xi), & \dots, & \frac{\partial f_1}{\partial x_N}(x + \theta_1 \xi) \\ \vdots & \ddots & \vdots \\ \frac{\partial f_N}{\partial x_1}(x + \theta_N \xi), & \dots, & \frac{\partial f_N}{\partial x_N}(x + \theta_N \xi) \end{bmatrix},$$

so that  $A\xi = 0$ . On the other hand,  $\det A \neq 0$ , so  $\xi = 0$ , i.e.,  $x = y$ .  $\square$

**Theorem 5.1.4.** *Let  $\emptyset \neq U \subset \mathbb{R}^N$  be open,  $N \leq M$ , and  $f \in C^1(U, \mathbb{R}^M)$  be such that  $\text{rank } J_f(x) = N$  for all  $x \in U$ . Then  $f$  is locally injective on  $U$ .*

*Proof.* Let  $x_0 \in U$ . Without loss of generality suppose that

$$\text{rank} \begin{bmatrix} \frac{\partial f_1}{\partial x_1}(x_0), & \dots, & \frac{\partial f_1}{\partial x_N}(x_0) \\ \vdots & \ddots & \vdots \\ \frac{\partial f_N}{\partial x_1}(x_0), & \dots, & \frac{\partial f_N}{\partial x_N}(x_0) \end{bmatrix} = N.$$

Let  $\tilde{f} := (f_1, \dots, f_N)$ . It follows that

$$J_{\tilde{f}}(x_0) = \begin{bmatrix} \frac{\partial f_1}{\partial x_1}(x_0), & \dots, & \frac{\partial f_1}{\partial x_N}(x_0) \\ \vdots & \ddots & \vdots \\ \frac{\partial f_N}{\partial x_1}(x_0), & \dots, & \frac{\partial f_N}{\partial x_N}(x_0) \end{bmatrix},$$

so that  $\det J_{\tilde{f}}(x_0) \neq 0$ .

By Lemma 5.1.3,  $\tilde{f}$ —and hence  $f$ —is therefore locally injective at  $x_0$ .  $\square$

*Example.* The function

$$f: \mathbb{R} \rightarrow \mathbb{R}^2, \quad x \mapsto (\cos x, \sin x)$$

satisfies the hypothesis of Theorem 5.1.4 and thus is locally injective. Nevertheless,

$$f(x + 2\pi) = f(x)$$

for all  $x \in \mathbb{R}$ , so  $f$  is not injective.

Next, we turn to an application of local injectivity:

**Lemma 5.1.5.** *Let  $\emptyset \neq U \subset \mathbb{R}^N$  be open, and let  $f \in C^1(U, \mathbb{R}^N)$  be such that  $\det J_f(x) \neq 0$  for  $x \in U$ . Then  $f(U)$  is open.*

*Proof.* Fix  $y_0 \in f(U)$ , and let  $x_0 \in U$  be such that  $f(x_0) = y_0$ .

Choose  $\delta > 0$  such that  $B_\delta[x_0] \subset U$  and such that  $f$  is injective on  $B_\delta[x_0]$  (the latter is possible by Lemma 5.1.3). Since  $f(\partial B_\delta[x_0])$  is compact and does not contain  $y_0$ ,

$$\epsilon := \frac{1}{2} \inf\{\|y_0 - f(x)\| : x \in \partial B_\delta[x_0]\} > 0.$$

We claim that  $B_\epsilon(y_0) \subset f(U)$ .

Fix  $y \in B_\epsilon(y_0)$ , and define

$$g: B_\delta[x_0] \rightarrow \mathbb{R}, \quad x \mapsto \|f(x) - y\|^2.$$

Then  $g$  is continuous, and thus attains its minimum at some  $\tilde{x} \in B_\delta[x_0]$ . Assume towards a contradiction that  $\tilde{x} \in \partial B_\delta[x_0]$ . It then follows that

$$\sqrt{g(\tilde{x})} = \|f(\tilde{x}) - y\| \geq \underbrace{\|f(\tilde{x}) - y_0\|}_{\geq 2\epsilon} - \underbrace{\|y_0 - y\|}_{< \epsilon} > \epsilon > \|y_0 - y\| = \sqrt{g(x_0)},$$

and thus  $g(\tilde{x}) > g(x_0)$ , which is a contradiction. It follows that  $\tilde{x} \in B_\delta(x_0)$ .

Consequently,  $\nabla g(\tilde{x}) = 0$ . Since

$$g(x) = \sum_{j=1}^N (f_j(x) - y_j)^2$$

for  $x \in B_\delta[x_0]$ , it follows that

$$\frac{\partial g}{\partial x_k}(x) = 2 \sum_{j=1}^N \frac{\partial f_j}{\partial x_k}(x)(f_j(x) - y_j)$$

for  $k = 1, \dots, N$  and  $x \in B_\delta(x_0)$ . In particular,

$$0 = \sum_{j=1}^N \frac{\partial f_j}{\partial x_k}(\tilde{x})(f_j(\tilde{x}) - y_j)$$

for  $k = 1, \dots, N$  and therefore

$$J_f(\tilde{x})f(\tilde{x}) = J_f(\tilde{x})y,$$

so that  $f(\tilde{x}) = y$ . It follows that  $y = f(\tilde{x}) \in f(B_\delta(x_0)) \subset f(U)$ .  $\square$

**Theorem 5.1.6.** *Let  $\emptyset \neq U \subset \mathbb{R}^N$  be open,  $N \geq M$ , and  $f \in C^1(U, \mathbb{R}^M)$  with  $\text{rank } J_f(x) = M$  for  $x \in U$ . Then  $f(U)$  is open.*

*Proof.* Let  $y = (y_1, \dots, y_N) \in U$ . We need to show that  $f(U)$  is a neighborhood of  $f(y)$ . Without loss of generality suppose that

$$\det \begin{bmatrix} \frac{\partial f_1}{\partial x_1}(y), & \dots, & \frac{\partial f_1}{\partial x_M}(y) \\ \vdots & \ddots & \vdots \\ \frac{\partial f_M}{\partial x_1}(y), & \dots, & \frac{\partial f_M}{\partial x_M}(y) \end{bmatrix} \neq 0$$

and—making  $U$  smaller if necessary—even that

$$\det \begin{bmatrix} \frac{\partial f_1}{\partial x_1}(x), & \dots, & \frac{\partial f_1}{\partial x_M}(x) \\ \vdots & \ddots & \vdots \\ \frac{\partial f_M}{\partial x_1}(x), & \dots, & \frac{\partial f_M}{\partial x_M}(x) \end{bmatrix} \neq 0$$

for  $x \in U$ . Consider the open subset

$$\tilde{U} := \{(x_1, \dots, x_M) \in \mathbb{R}^M : (x_1, \dots, x_M, y_{M+1}, \dots, y_N) \in U\}$$

of  $\mathbb{R}^m$  and define

$$\tilde{f}: \tilde{U} \rightarrow \mathbb{R}^M, \quad x \mapsto f(x_1, \dots, x_M, y_{M+1}, \dots, y_N).$$

Then  $\tilde{f}$  is of class  $\mathcal{C}^1$  on  $\tilde{U}$  and  $\det J_{\tilde{f}}(x) \neq 0$  on  $\tilde{U}$ . By Lemma 5.1.5,  $\tilde{f}(\tilde{U})$  is open in  $\mathbb{R}^M$ . Consequently,  $f(U) \supset \tilde{f}(\tilde{U})$  is a neighborhood of  $f(y)$ .  $\square$

### Exercises

1. Let  $U := \mathbb{R}^2 \setminus \{(0, 0)\}$ , and let

$$f: U \rightarrow \mathbb{R}^2, \quad (x, y) \mapsto \left( \frac{x}{\sqrt{x^2 + y^2}}, \frac{y}{\sqrt{x^2 + y^2}} \right).$$

- (a) Calculate  $\det J_f(x, y)$  for all  $(x, y) \in U$ .  
 (b) Determine  $f(U)$ . Does it contain a non-empty open subset?
2. Is the following “theorem” true or not?

*Let  $\emptyset \neq U \subset \mathbb{R}^N$  be open, let  $x_0 \in U$ , and let  $f \in \mathcal{C}^1(U, \mathbb{R}^N)$  be such that  $f(V)$  is open for each open neighborhood  $V \subset U$  of  $x_0$ . Then  $\det J_f(x_0) \neq 0$ .*

Give a proof or provide a counterexample.

3. Let  $\emptyset \neq U \subset \mathbb{R}^N$  be open, and let  $f \in \mathcal{C}^1(U, \mathbb{R}^N)$  be such that  $\det J_f(x) \neq 0$  for all  $x \in U$ .



(a) Show that

$$U \rightarrow \mathbb{R}, \quad x \mapsto \|f(x)\|$$

has no local maximum.

(b) Suppose that  $U$  is bounded (so that  $\bar{U}$  is compact) and that  $f$  has a continuous extension  $\tilde{f}: \bar{U} \rightarrow \mathbb{R}^N$ . Show that the continuous map

$$\bar{U} \rightarrow \mathbb{R}, \quad x \mapsto \|\tilde{f}(x)\|$$

attains its maximum on  $\partial U$ .

## 5.2 The Implicit Function Theorem

The function we have encountered so far were “explicitly” given: they were described by some sort of algebraic expression. Many functions occurring “in nature”, however, are not that easily accessible. For instance, a real-valued function of two variables can be thought of as a surface in three-dimensional space. The level curves can often—at least locally—be parametrized as functions—even though it may be impossible to describe them explicitly.

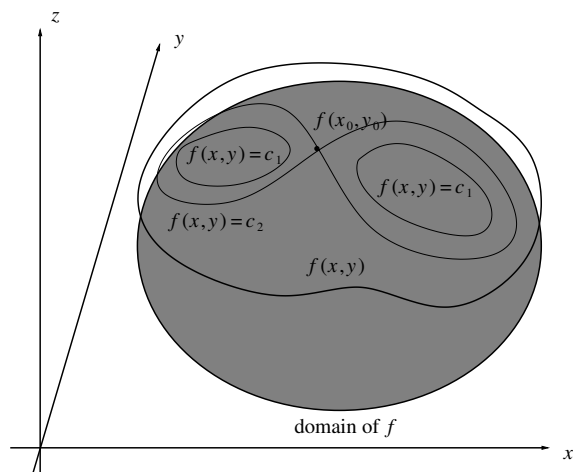

Figure 5.1: Level curves

In the figure above, the curves corresponding to the level  $c_1$  can locally be parametrized whereas the curve corresponding to the level  $c_2$  allows no such parametrization close to  $f(x_0, y_0)$ .

More generally (and more rigorously), given equations

$$f_j(x_1, \dots, x_M, y_1, \dots, y_N) = 0$$

for  $j = 1, \dots, N$ , can  $y_1, \dots, y_N$  be uniquely expressed as functions  $y_j = \phi_j(x_1, \dots, x_M)$ ?

*Examples.*

1. “Yes” if  $f(x, y) = x^2 - y$ : choose  $\phi(x) = x^2$ .
2. “No” if  $f(x, y) = y^2 - x$ : both  $\phi(x) = \sqrt{x}$  and  $\psi(x) = -\sqrt{x}$  solve the equation.

The implicit function theorem will provide necessary conditions for a positive answer.

**Lemma 5.2.1.** *Let  $\emptyset \neq K \subset \mathbb{R}^N$  be compact, and let  $f : K \rightarrow \mathbb{R}^M$  be injective and continuous. Then the inverse map*

$$f^{-1} : f(K) \rightarrow K, \quad f(x) \mapsto x$$

*is also continuous.*

*Proof.* Let  $x \in K$ , and let  $(x_n)_{n=1}^{\infty}$  be a sequence in  $K$  such that  $\lim_{n \rightarrow \infty} f(x_n) = f(x)$ . We need to show that  $\lim_{n \rightarrow \infty} x_n = x$ . Assume that this is not true. Then there exists  $\epsilon_0 > 0$  and a subsequence  $(x_{n_k})_{k=1}^{\infty}$  of  $(x_n)_{n=1}^{\infty}$  such that  $\|x_{n_k} - x\| \geq \epsilon_0$  for all  $k \in \mathbb{N}$ . Since  $K$  is compact, we may without loss of generality suppose that  $(x_{n_k})_{k=1}^{\infty}$  converges to some  $x' \in K$ . Since  $f$  is continuous, this means that  $\lim_{k \rightarrow \infty} f(x_{n_k}) = f(x')$ . Since  $\lim_{k \rightarrow \infty} f(x_{n_k}) = \lim_{n \rightarrow \infty} f(x_n)$ , this implies  $f(x') = f(x)$ ; the injectivity of  $f$  then yields  $x' = x$ , so that  $\lim_{k \rightarrow \infty} x_{n_k} = x$ . This, however, contradicts  $\|x_{n_k} - x\| \geq \epsilon_0$  for all  $k \in \mathbb{N}$ .  $\square$

**Proposition 5.2.2** (Baby Inverse Function Theorem). *Let  $I \subset \mathbb{R}$  be an open interval, let  $f \in C^1(I, \mathbb{R})$ , and let  $x_0 \in I$  be such that  $f'(x_0) \neq 0$ . Then there exists an open interval  $J \subset I$  with  $x_0 \in J$  such that  $f$  restricted to  $J$  is injective. Moreover,  $f^{-1} : f(J) \rightarrow \mathbb{R}$  is a  $C^1$ -function such that*

$$\frac{df^{-1}}{dy}(f(x)) = \frac{1}{f'(x)} \tag{5.1}$$

*for  $x \in J$ .*

*Proof.* Without loss of generality, let  $f'(x_0) > 0$ . Since  $I$  is open, and since  $f'$  is continuous, there exists  $\epsilon > 0$  with  $[x_0 - \epsilon, x_0 + \epsilon] \subset I$  such that  $f'(x) > 0$  for all  $x \in [x_0 - \epsilon, x_0 + \epsilon]$ . It follows that  $f$  is strictly increasing on  $[x_0 - \epsilon, x_0 + \epsilon]$  and therefore injective. From Lemma 5.2.1, it follows that  $f^{-1} : f([x_0 - \epsilon, x_0 + \epsilon]) \rightarrow \mathbb{R}$  is continuous. Let  $J := (x_0 - \epsilon, x_0 + \epsilon)$ , so that  $f(J)$  is an open interval and  $f^{-1} : f(J) \rightarrow \mathbb{R}$  is continuous.

Let  $y, \tilde{y} \in f(J)$  such that  $y \neq \tilde{y}$ . Let  $x, \tilde{x} \in J$  be such that  $y = f(x)$  and  $\tilde{y} = f(\tilde{x})$ . Since  $f^{-1}$  is continuous,

$$\lim_{\tilde{y} \rightarrow y} \frac{f^{-1}(\tilde{y}) - f^{-1}(y)}{\tilde{y} - y} = \lim_{\tilde{x} \rightarrow x} \frac{\tilde{x} - x}{f(\tilde{x}) - f(x)} = \frac{1}{f'(x)},$$

which proves (5.1). We see from (5.1) that  $\frac{df^{-1}}{dy}$  is continuous on  $f(J)$ .  $\square$

**Lemma 5.2.3.** *Let  $\emptyset \neq U \subset \mathbb{R}^N$  be open, let  $f \in C^1(U, \mathbb{R}^N)$ , and let  $x_0 \in U$  be such that  $\det J_f(x_0) \neq 0$ . Then there exists a neighborhood  $V \subset U$  of  $x_0$  and  $C > 0$  such that*

$$\|f(x) - f(x_0)\| \geq C\|x - x_0\|$$

for all  $x \in V$ .

*Proof.* Since  $\det J_f(x_0) \neq 0$ , the matrix  $J_f(x_0)$  is invertible. For all  $x \in \mathbb{R}^N$ , we have

$$\|x\| = \|J_f(x_0)^{-1}J_f(x_0)x\| \leq \|J_f(x_0)^{-1}\| \|J_f(x_0)x\|$$

and therefore

$$\frac{1}{\|J_f(x_0)^{-1}\|} \|x\| \leq \|J_f(x_0)x\|.$$

Let  $C := \frac{1}{2\|J_f(x_0)^{-1}\|}$ , so that

$$2C\|x - x_0\| \leq \|J_f(x_0)(x - x_0)\|$$

for all  $x \in \mathbb{R}^N$ . Choose  $\delta > 0$  such that  $B_\delta(x_0) \subset U$  and

$$\|f(x) - f(x_0) - J_f(x_0)(x - x_0)\| \leq C\|x - x_0\|$$

for all  $x \in B_\delta(x_0) =: V$ . It follows that

$$\begin{aligned} C\|x - x_0\| &\geq \|f(x) - f(x_0) - J_f(x_0)(x - x_0)\| \\ &\geq \|J_f(x_0)(x - x_0)\| - \|f(x) - f(x_0)\| \\ &\geq 2C\|x - x_0\| - \|f(x) - f(x_0)\| \end{aligned}$$

for all  $x \in V$ , which proves the claim.  $\square$

**Lemma 5.2.4.** *Let  $\emptyset \neq U \subset \mathbb{R}^N$  be open, let  $f \in C^1(U, \mathbb{R}^N)$  be injective such that  $\det J_f(x) \neq 0$  for all  $x \in U$ . Then  $f(U)$  is open and  $f^{-1}$  is a  $C^1$ -function such that  $J_{f^{-1}}(f(x)) = J_f(x)^{-1}$  for all  $x \in U$ .*

*Proof.* The openness of  $f(U)$  follows immediately from Theorem 5.1.6.

Fix  $x_0 \in U$  and define the continuous function

$$g: U \rightarrow \mathbb{R}^N, \quad x \mapsto \begin{cases} \frac{f(x) - f(x_0) - J_f(x_0)(x - x_0)}{\|x - x_0\|}, & x \neq x_0, \\ 0, & x = x_0. \end{cases}$$

With  $C > 0$  as in Lemma 5.2.3,  $y_0 = f(x_0)$ , and  $y = f(x)$  for  $x \in U$ , we obtain

$$\begin{aligned} \frac{1}{C}\|y - y_0\| \|J_f(x_0)^{-1}g(x)\| &\geq \|x_0 - x\| \|J_f(x_0)^{-1}g(x)\| \\ &= \|J_f(x_0)^{-1}(f(x) - f(x_0)) - (x - x_0)\|. \end{aligned}$$

Since  $f^{-1}$  is continuous at  $y_0$  by Lemma 5.2.1, we see that

$$\frac{\|f^{-1}(y) - f^{-1}(y_0) - J_f(x_0)^{-1}(y - y_0)\|}{\|y - y_0\|} \leq \frac{1}{C} \|J_f(x_0)^{-1}g(x)\| \rightarrow 0$$

as  $y \rightarrow y_0$ . Consequently,  $f^{-1}$  is totally differentiable at  $y_0$  with  $J_{f^{-1}}(y_0) = J_f(x_0)^{-1}$ .

Since  $y_0 \in f(U)$  was arbitrary, we conclude that  $f^{-1}$  is totally differentiable at each point of  $y \in f(U)$  with  $J_{f^{-1}}(y) = J_f(x)^{-1}$ , where  $x = f^{-1}(y)$ . By Cramer's Rule, the entries of  $J_{f^{-1}}(y) = J_f(x)^{-1}$  are rational functions of the entries of  $J_f(x)$ . It follows that  $f^{-1} \in \mathcal{C}^1(f(U), \mathbb{R}^N)$ .  $\square$

**Theorem 5.2.5** (Inverse Function Theorem). *Let  $\emptyset \neq U \subset \mathbb{R}^N$  be open, let  $f \in \mathcal{C}^1(U, \mathbb{R}^N)$ , and let  $x_0 \in U$  be such that  $\det J_f(x_0) \neq 0$ . Then there exists an open neighborhood  $V \subset U$  of  $x_0$  such that  $f$  is injective on  $V$ ,  $f(V)$  is open, and  $f^{-1}: f(V) \rightarrow \mathbb{R}^N$  is a  $\mathcal{C}^1$ -function such that  $J_{f^{-1}} = J_f^{-1}$ .*

*Proof.* By Theorem 5.1.4, there exists an open neighborhood  $V \subset U$  of  $x_0$  such that  $f$  restricted to  $V$  is injective and  $\det J_f(x) \neq 0$  for  $x \in V$ . The remaining claims then follow immediately from Lemma 5.2.4.  $\square$

For the implicit function theorem, we consider the following situation: Let  $\emptyset \neq U \subset \mathbb{R}^{M+N}$  be open, and let

$$f: U \rightarrow \mathbb{R}^N, \quad (x_1, \dots, x_M, y_1, \dots, y_N) \mapsto f(\underbrace{x_1, \dots, x_M}_{=:x}, \underbrace{y_1, \dots, y_N}_{=:y})$$

be such that  $\frac{\partial f}{\partial x_k}$  and  $\frac{\partial f}{\partial y_j}$  exist on  $U$  for  $k = 1, \dots, M$  and  $j = 1, \dots, N$ . We define

$$\frac{\partial f}{\partial x}(x, y) := \begin{bmatrix} \frac{\partial f_1}{\partial x_1}(x, y), & \dots, & \frac{\partial f_1}{\partial x_M}(x, y) \\ \vdots & \ddots & \vdots \\ \frac{\partial f_N}{\partial x_1}(x, y), & \dots, & \frac{\partial f_N}{\partial x_M}(x, y) \end{bmatrix}$$

and

$$\frac{\partial f}{\partial y}(x, y) := \begin{bmatrix} \frac{\partial f_1}{\partial y_1}(x, y), & \dots, & \frac{\partial f_1}{\partial y_N}(x, y) \\ \vdots & \ddots & \vdots \\ \frac{\partial f_N}{\partial y_1}(x, y), & \dots, & \frac{\partial f_N}{\partial y_N}(x, y) \end{bmatrix}.$$

**Theorem 5.2.6** (Implicit Function Theorem). *Let  $\emptyset \neq U \subset \mathbb{R}^{M+N}$  be open, let  $f \in \mathcal{C}^1(U, \mathbb{R}^N)$ , and let  $(x_0, y_0) \in U$  be such that  $f(x_0, y_0) = 0$  and  $\det \frac{\partial f}{\partial y}(x_0, y_0) \neq 0$ . Then there exist neighborhoods  $V \subset \mathbb{R}^M$  of  $x_0$  and  $W \subset \mathbb{R}^N$  of  $y_0$  with  $V \times W \subset U$  and a unique  $\phi \in \mathcal{C}^1(V, \mathbb{R}^N)$  such that:*

- (i)  $\phi(x_0) = y_0$ ;

(ii)  $f(x, y) = 0$  if and only if  $\phi(x) = y$  for all  $(x, y) \in V \times W$ .

Moreover, we have

$$J_\phi = - \left( \frac{\partial f}{\partial y} \right)^{-1} \frac{\partial f}{\partial x}.$$

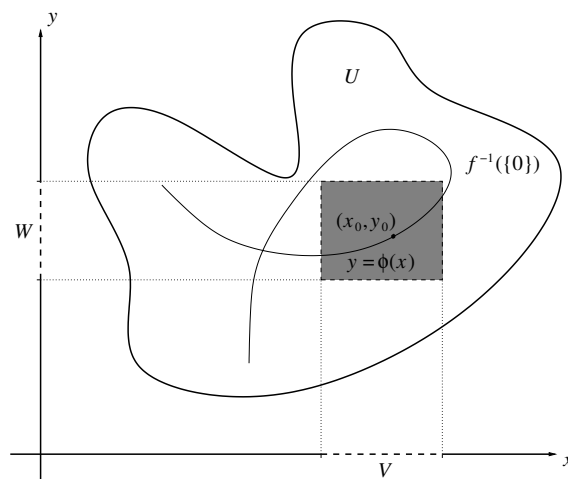

Figure 5.2: The implicit function theorem

*Proof.* Define

$$F: U \rightarrow \mathbb{R}^{M+N}, \quad (x, y) \mapsto (x, f(x, y)),$$

so that  $F \in C^1(U, \mathbb{R}^{M+N})$  with

$$J_F(x, y) = \left[ \begin{array}{c|c} I_M & 0 \\ \hline \frac{\partial f}{\partial x}(x, y) & \frac{\partial f}{\partial y}(x, y) \end{array} \right].$$

It follows that

$$\det J_F(x_0, y_0) = \det \frac{\partial f}{\partial y}(x_0, y_0) \neq 0.$$

By the **Inverse Function Theorem**, there exist open neighborhoods  $V \subset \mathbb{R}^M$  of  $x_0$  and  $W \subset \mathbb{R}^N$  of  $y_0$  with  $V \times W \subset U$  such that:

- $F$  restricted to  $V \times W$  is injective;
- $F(V \times W)$  is open (and therefore a neighborhood of  $(x_0, 0) = F(x_0, y_0)$ );
- $F^{-1} \in C^1(F(V \times W), \mathbb{R}^{M+N})$ .

Let

$$\pi: \mathbb{R}^{M+N} \rightarrow \mathbb{R}^N, \quad (x, y) \mapsto y.$$

Then we have for  $(x, w) \in F(V \times W)$  that

$$(x, w) = F(F^{-1}(x, w)) = F(x, \pi(F^{-1}(x, w))) = (x, f(x, \pi(F^{-1}(x, w))))$$

and thus

$$w = f(x, \pi(F^{-1}(x, w))).$$

Since  $\{(x, 0) : x \in V\} \subset F(V \times W)$ , on setting  $w = 0$  we can define

$$\phi: V \rightarrow \mathbb{R}^N, \quad x \mapsto \pi(F^{-1}(x, 0)).$$

It follows that  $\phi \in C^1(V, \mathbb{R}^N)$  with  $\phi(x_0) = y_0$  and  $f(x, \phi(x)) = 0$  for all  $x \in V$ . If  $(x, y) \in V \times W$  is such that  $f(x, y) = 0 = f(x, \phi(x))$ , the injectivity of  $F$ —and hence of  $f$ —yields  $y = \phi(x)$ . This also proves the uniqueness of  $\phi$ .

Let

$$\psi: V \rightarrow \mathbb{R}^{M+N}, \quad x \mapsto (x, \phi(x)),$$

so that  $\psi \in C^1(V, \mathbb{R}^{M+N})$ , with

$$J_\psi(x) = \begin{bmatrix} I_M \\ J_\phi(x) \end{bmatrix}$$

for  $x \in V$ . Since  $f \circ \psi = 0$ , the chain rule yields for  $x \in V$  that

$$\begin{aligned} 0 &= J_f(\psi(x))J_\psi(x) \\ &= \left[ \frac{\partial f}{\partial x}(\psi(x)) \mid \frac{\partial f}{\partial y}(\psi(x)) \right] \begin{bmatrix} I_M \\ J_\phi(x) \end{bmatrix} \\ &= \frac{\partial f}{\partial x}(x, \phi(x)) + \frac{\partial f}{\partial y}(x, \phi(x))J_\phi(x) \end{aligned}$$

and therefore

$$J_\phi(x) = - \left( \frac{\partial f}{\partial y}(x, \phi(x)) \right)^{-1} \frac{\partial f}{\partial x}(x, \phi(x)).$$

This completes the proof.  $\square$

*Example.* The system

$$\begin{aligned} x^2 + y^2 - 2z^2 &= 0, \\ x^2 + 2y^2 + z^2 &= 4 \end{aligned}$$

of equations has the solution  $(x, y, z) = (x_0, y_0, z_0)$ , where  $x_0 = 0$ ,  $y_0 = \sqrt{\frac{8}{5}}$ , and  $z_0 = \sqrt{\frac{4}{5}}$ .

Define

$$f: \mathbb{R}^3 \rightarrow \mathbb{R}^2, \quad (x, y, z) \mapsto (x^2 + y^2 - 2z^2, x^2 + 2y^2 + z^2 - 4),$$

so that  $f(x_0, y_0, z_0) = 0$ . Note that

$$\begin{bmatrix} \frac{\partial f_1}{\partial y}(x, y, z) & \frac{\partial f_1}{\partial z}(x, y, z) \\ \frac{\partial f_2}{\partial y}(x, y, z) & \frac{\partial f_2}{\partial z}(x, y, z) \end{bmatrix} = \begin{bmatrix} 2y & -4z \\ 4y & 2z \end{bmatrix}.$$

Hence,

$$\det \begin{bmatrix} \frac{\partial f_1}{\partial y}(x, y, z) & \frac{\partial f_1}{\partial z}(x, y, z) \\ \frac{\partial f_2}{\partial y}(x, y, z) & \frac{\partial f_2}{\partial z}(x, y, z) \end{bmatrix} = 4yz + 16yz = 20yz \neq 0$$

whenever  $y \neq 0 \neq z$ . By the **Implicit Function Theorem**, there exists  $\epsilon > 0$  and a unique  $\phi \in C^1((-\epsilon, \epsilon), \mathbb{R}^2)$  such that

$$\phi_1(0) = \sqrt{\frac{8}{5}}, \quad \phi_2(0) = \sqrt{\frac{4}{5}}, \quad \text{and} \quad f(x, \phi_1(x), \phi_2(x)) = 0$$

for  $x \in (-\epsilon, \epsilon)$ . Moreover, we have

$$\begin{aligned} J_\phi(x) &= \begin{bmatrix} \frac{d\phi_1}{dx}(x) \\ \frac{d\phi_2}{dx}(x) \end{bmatrix} = - \begin{bmatrix} 2y & -4z \\ 4y & 2z \end{bmatrix}^{-1} \begin{bmatrix} 2x \\ 2x \end{bmatrix} \\ &= -\frac{1}{20yz} \begin{bmatrix} 2z & 4z \\ -4y & 2y \end{bmatrix} \begin{bmatrix} 2x \\ 2x \end{bmatrix} = - \begin{bmatrix} \frac{12xz}{20yz} \\ \frac{-4yx}{20yz} \end{bmatrix} = \begin{bmatrix} -\frac{3x}{5y} \\ \frac{x}{5z} \end{bmatrix} \end{aligned}$$

and thus

$$\phi_1'(x) = -\frac{3}{5} \frac{x}{\phi_1(x)} \quad \text{and} \quad \phi_2'(x) = \frac{1}{5} \frac{x}{\phi_2(x)}$$

for  $x \in (-\epsilon, \epsilon)$ .

### Exercises

1. Let

$$f: \mathbb{R}^2 \rightarrow \mathbb{R}, \quad (x, y) \mapsto x^2 + y^2.$$

Show that there exists  $\epsilon > 0$  and a  $C^1$ -function  $\phi: (-\epsilon, \epsilon) \rightarrow \mathbb{R}$  with  $\phi(0) = 1$  such that  $y = \phi(x)$  solves the equation  $f(x, y) = 1$  for all  $x \in \mathbb{R}$  with  $|x| < \epsilon$ . Show *without explicitly determining*  $\phi$  that

$$\phi'(x) = -\frac{x}{\phi(x)} \quad \text{for } x \in (-\epsilon, \epsilon).$$

2. Show that there exists  $\epsilon > 0$  and  $u, v, w \in C^1(B_\epsilon((1, 1)), \mathbb{R})$  such that  $u(1, 1) = 1$ ,  $v(1, 1) = 1$ ,  $w(1, 1) = -1$ ,

$$\begin{aligned}u(x, y)^5 + x v(x, y)^2 - y + w(x, y) &= 0, \\v(x, y)^5 + y u(x, y) - x + w(x, y) &= 0,\end{aligned}$$

and

$$w(x, y)^4 + y^5 - x^4 = 1$$

for  $(x, y) \in B_\epsilon((1, 1))$ .

3. Let  $f_0, \dots, f_{n-1}: \mathbb{R} \rightarrow \mathbb{R}$  be continuously differentiable, and let

$$p: \mathbb{R}^2 \rightarrow \mathbb{R}, \quad (x, y) \mapsto y^n + f_{n-1}(x)y^{n-1} + \dots + f_1(x)y + f_0(x).$$

Suppose that  $f_0(0) = 0$  and that  $f_1(0) \neq 0$ . Show that there exists  $\epsilon > 0$  and a unique  $C^1$ -function  $\phi: (-\epsilon, \epsilon) \rightarrow \mathbb{R}$  with  $\phi(0) = 0$  such that  $p(x, \phi(x)) = 0$  for all  $x \in (-\epsilon, \epsilon)$ .

4. Let  $f \in C^1(\mathbb{R}^2, \mathbb{R})$  be such that

$$f^{-1}(\{0\}) = \{(x, y) \in \mathbb{R}^2 : (x-1)^2 + y^2 = 1 \text{ or } (x+1)^2 + y^2 = 1\}.$$

(a) Sketch  $f^{-1}(\{0\})$ .

(b) Show that

$$\frac{\partial f}{\partial y}(0, 0) = \frac{\partial f}{\partial x}(0, 0) = 0.$$

### 5.3 Local Extrema under Constraints

*Example.* Let

$$f: B_1[(0, 0)] \rightarrow \mathbb{R}, \quad (x, y) \mapsto 4x^2 - 3xy.$$

Since  $B_1[(0, 0)]$  is compact and  $f$  is continuous there exist  $(x_1, y_1), (x_2, y_2) \in B_1[(0, 0)]$  such that

$$f(x_1, y_1) = \sup_{(x, y) \in B_1[(0, 0)]} f(x, y) \quad \text{and} \quad f(x_2, y_2) = \inf_{(x, y) \in B_1[(0, 0)]} f(x, y).$$

The problem is to find  $(x_1, y_1)$  and  $(x_2, y_2)$ . If  $(x_1, y_1)$  and  $(x_2, y_2)$  are in  $B_1((0, 0))$ , then  $f$  has local extrema at  $(x_1, y_1)$  and  $(x_2, y_2)$ , and we know how to determine them.

Since

$$\frac{\partial f}{\partial x}(x, y) = 8x - 3y \quad \text{and} \quad \frac{\partial f}{\partial y}(x, y) = -3x,$$



the only stationary point for  $f$  in  $B_1((0, 0))$  is  $(0, 0)$ . Furthermore, we have

$$\frac{\partial^2 f}{\partial x^2}(x, y) = 8, \quad \frac{\partial^2 f}{\partial y^2}(x, y) = 0, \quad \text{and} \quad \frac{\partial^2 f}{\partial x \partial y}(x, y) = -3,$$

so that

$$(\text{Hess } f)(x, y) = \begin{bmatrix} 8 & -3 \\ -3 & 0 \end{bmatrix}.$$

Since  $\det(\text{Hess } f)(0, 0) = -9$ , it follows that  $f$  has a saddle at  $(0, 0)$ .

Hence,  $(x_1, y_1)$  and  $(x_2, y_2)$  must lie in  $\partial B_1[(0, 0)] \dots$

There are, of course, ways to steer around the problem that occurs in this example. For instance, we might parametrize the unit circle via

$$[0, 2\pi] \rightarrow \mathbb{R}^2, \quad t \mapsto (\cos t, \sin t)$$

and then determine the minimum and maximum—along with the values of  $t$  where they are attained—of

$$[0, 2\pi] \rightarrow \mathbb{R}, \quad t \mapsto 4(\cos t)^2 - 3(\cos t)(\sin t).$$

This would be an *ad hoc* solution that actually might lead to success but is specific to the particular problem. Instead, we develop a general approach to determine so-called local extrema of functions under constraints.

We first make precise what this is supposed to mean.

**Definition 5.3.1.** Let  $\emptyset \neq D \subset \mathbb{R}^N$ , and let  $f, \phi: D \rightarrow \mathbb{R}$ . We say that  $f$  has a *local maximum* [*minimum*] at  $x_0 \in D$  under the constraint  $\phi(x) = 0$  if  $\phi(x_0) = 0$  and if there exists a neighborhood  $U$  of  $x_0$  such that  $f(x) \leq f(x_0)$  [ $f(x) \geq f(x_0)$ ] for all  $x \in U \cap D$  with  $\phi(x) = 0$ . In either case, we say that  $f$  has a *local extremum* at  $x_0$  under the constraint  $\phi(x) = 0$ .

**Theorem 5.3.2** (Lagrange Multiplier Theorem). *Let  $N \geq 2$ , let  $\emptyset \neq U \subset \mathbb{R}^N$  be open, let  $f, \phi \in C^1(U, \mathbb{R})$ , and let  $x_0 \in U$  be such that  $f$  has a local extremum at  $x_0$  under the constraint  $\phi(x) = 0$  and such that  $\nabla \phi(x_0) \neq 0$ . Then there exists  $\lambda \in \mathbb{R}$ , a Lagrange multiplier, such that*

$$\nabla f(x_0) = \lambda \nabla \phi(x_0).$$

*Proof.* Without loss of generality suppose that  $\frac{\partial \phi}{\partial x_N}(x_0) \neq 0$ . By the **Implicit Function Theorem**, there exists an open neighborhood  $V \subset \mathbb{R}^{N-1}$  of  $\tilde{x}_0 := (x_{0,1}, \dots, x_{0,N-1})$  and  $\psi \in C^1(V, \mathbb{R})$  such that

$$\psi(\tilde{x}_0) = x_{0,N} \quad \text{and} \quad \phi(\tilde{x}, \psi(\tilde{x})) = 0 \quad \text{for all } \tilde{x} \in V.$$

It follows that

$$0 = \frac{\partial \phi}{\partial x_j}(\tilde{x}, \psi(\tilde{x})) + \frac{\partial \phi}{\partial x_N}(\tilde{x}, \psi(\tilde{x})) \frac{\partial \psi}{\partial x_j}(\tilde{x})$$

for all  $j = 1, \dots, N - 1$  and  $\tilde{x} \in V$ . In particular,

$$0 = \frac{\partial \phi}{\partial x_j}(x_0) + \frac{\partial \phi}{\partial x_N}(x_0) \frac{\partial \psi}{\partial x_j}(\tilde{x}_0) \quad (5.2)$$

holds for all  $j = 1, \dots, N - 1$ .

The function

$$g: V \rightarrow \mathbb{R}, \quad (x_1, \dots, x_{N-1}) \mapsto f(x_1, \dots, x_{N-1}, \psi(x_1, \dots, x_{N-1}))$$

has a local extremum at  $\tilde{x}_0$ , so that  $\nabla g(\tilde{x}_0) = 0$ , and thus

$$0 = \frac{\partial g}{\partial x_j}(\tilde{x}_0) = \frac{\partial f}{\partial x_j}(x_0) + \frac{\partial f}{\partial x_N}(x_0) \frac{\partial \psi}{\partial x_j}(\tilde{x}_0) \quad (5.3)$$

for  $j = 1, \dots, N - 1$ . Set

$$\lambda := \frac{\partial f}{\partial x_N}(x_0) \left( \frac{\partial \phi}{\partial x_N}(x_0) \right)^{-1},$$

so that  $\frac{\partial f}{\partial x_N}(x_0) = \lambda \frac{\partial \phi}{\partial x_N}(x_0)$ . From (5.3) and (5.2), it then follows that

$$\frac{\partial f}{\partial x_j}(x_0) = -\frac{\partial f}{\partial x_N}(x_0) \frac{\partial \psi}{\partial x_j}(\tilde{x}_0) = -\lambda \frac{\partial \phi}{\partial x_N}(x_0) \frac{\partial \psi}{\partial x_j}(\tilde{x}_0) = \lambda \frac{\partial \phi}{\partial x_j}(x_0)$$

holds as well for  $j = 1, \dots, N - 1$ . Thus  $\nabla f(x_0) = \lambda \nabla \phi(x_0)$ .  $\square$

*Example.* Consider again

$$f: B_1[(0, 0)] \rightarrow \mathbb{R}, \quad (x, y) \mapsto 4x^2 - 3xy.$$

Since  $f$  has no local extrema on  $B_1((0, 0))$ , it *must* attain its minimum and maximum on  $\partial B_1[(0, 0)]$ .

Let

$$\phi: \mathbb{R}^2 \rightarrow \mathbb{R}, \quad (x, y) \mapsto x^2 + y^2 - 1,$$

so that

$$\partial B_1[(0, 0)] = \{(x, y) \in \mathbb{R}^2 : \phi(x, y) = 0\}.$$

Hence, the minimum and maximum of  $f$  on  $B_1[(0, 0)]$  are local extrema under the constraint  $\phi(x, y) = 0$ . Since  $\nabla \phi(x, y) = (2x, 2y)$  for  $x, y \in \mathbb{R}$ ,  $\nabla \phi$  never vanishes on  $\partial B_1[(0, 0)]$ .

Suppose that  $f$  has a local extremum at  $(x_0, y_0)$  under the constraint  $\phi(x, y) = 0$ . By the **Lagrange Multiplier Theorem**, there exists  $\lambda \in \mathbb{R}$  such that  $\nabla f(x_0, y_0) = \lambda \nabla \phi(x_0, y_0)$ , i.e.,

$$\begin{aligned} 8x_0 - 3y_0 &= 2\lambda x_0, \\ -3x_0 &= 2\lambda y_0. \end{aligned}$$

For notational simplicity, we write  $(x, y)$  instead of  $(x_0, y_0)$ . Solve the equations:

$$8x - 3y = 2\lambda x; \quad (5.4)$$

$$-3x = 2\lambda y; \quad (5.5)$$

$$x^2 + y^2 = 1. \quad (5.6)$$

From (5.5), it follows that  $x = -\frac{2}{3}\lambda y$ . Plugging this expression into (5.4), we obtain

$$-\frac{16}{3}\lambda y - 3y = -\frac{4}{3}\lambda^2 y. \quad (5.7)$$

*Case 1:*  $y = 0$ . Then (5.5) implies  $x = 0$ , which contradicts (5.6). Hence, this case cannot occur.

*Case 2:*  $y \neq 0$ . Dividing (5.7) by  $\frac{y}{3}$  yields

$$4\lambda^2 - 16\lambda - 9 = 0$$

and thus

$$\lambda^2 - 4\lambda - \frac{9}{4} = 0.$$

Completing the square, we obtain  $(\lambda - 2)^2 = 25/4$ , so that  $\lambda = 9/2$  or  $\lambda = -1/2$ .

*Case 2.1:*  $\lambda = \frac{9}{2}$ . Then (5.5) yields  $-3x = 9y$  and thus  $x = -3y$ . Plugging into (5.6), we get  $10y^2 = 1$ , so that  $y = \pm \frac{1}{\sqrt{10}}$ . Hence,  $(\frac{3}{\sqrt{10}}, -\frac{1}{\sqrt{10}})$  and  $(-\frac{3}{\sqrt{10}}, \frac{1}{\sqrt{10}})$  are possible candidates for extrema to be attained at.

*Case 2.2:*  $\lambda = -\frac{1}{2}$ . Then (5.5) yields  $-3x = -y$  and thus  $y = 3x$ . Plugging into (5.6), we get  $10x^2 = 1$ , so that  $x = \pm \frac{1}{\sqrt{10}}$ . Hence,  $(\frac{1}{\sqrt{10}}, \frac{3}{\sqrt{10}})$  and  $(-\frac{1}{\sqrt{10}}, -\frac{3}{\sqrt{10}})$  are possible candidates for extrema to be attained at.

Evaluating  $f$  at those points, we obtain:

$$\begin{aligned} f\left(\frac{3}{\sqrt{10}}, -\frac{1}{\sqrt{10}}\right) &= \frac{9}{2}; \\ f\left(-\frac{3}{\sqrt{10}}, \frac{1}{\sqrt{10}}\right) &= \frac{9}{2}; \\ f\left(\frac{1}{\sqrt{10}}, \frac{3}{\sqrt{10}}\right) &= -\frac{1}{2}; \\ f\left(-\frac{1}{\sqrt{10}}, -\frac{3}{\sqrt{10}}\right) &= -\frac{1}{2}. \end{aligned}$$

In summary,  $f$  has on  $B_1[(0, 0)]$  the maximum  $\frac{9}{2}$ , attained at  $(\frac{3}{\sqrt{10}}, -\frac{1}{\sqrt{10}})$  and  $(-\frac{3}{\sqrt{10}}, \frac{1}{\sqrt{10}})$ , and the minimum  $-\frac{1}{2}$ , which is attained at  $(\frac{1}{\sqrt{10}}, \frac{3}{\sqrt{10}})$  and  $(-\frac{1}{\sqrt{10}}, -\frac{3}{\sqrt{10}})$ .

Given a bounded, open set  $\emptyset \neq U \subset \mathbb{R}^N$ , an open subset  $V \supset \bar{U}$  of  $\mathbb{R}^N$ , and a  $C^1$ -function  $f: V \rightarrow \mathbb{R}$ , the following is a strategy to determine the minimum and maximum of  $f$  on  $\bar{U}$  (as well as those points in  $\bar{U}$  where they are attained):

- Determine all stationary points of  $f$  on  $U$ .
- If possible (with a reasonable amount of work), classify those stationary points and evaluate  $f$  at any local extrema.
- If classifying the stationary points isn't possible (or simply too much work), simply evaluate  $f$  at all of its stationary points.
- Describe  $\partial U$  in terms of a constraint  $\phi(x) = 0$  for some  $\phi \in \mathcal{C}^1(V, \mathbb{R})$  and check if the **Lagrange Multiplier Theorem** is applicable.
- If so, determine all  $x \in V$  with  $\phi(x) = 0$  and  $\nabla f(x) = \lambda \nabla \phi(x)$  for some  $\lambda \in \mathbb{R}$  and evaluate  $f$  at those points.
- Compare the values of  $f$  you obtain in the process, picking the largest and smallest ones.

This is *not* a fail-safe algorithm, but rather a strategy that may have to be modified depending on the circumstances (or that may not even work at all. . .).

*Example.* Let

$$K := \{(x, y, z) \in \mathbb{R}^3 : x^2 + 4y^2 + z^2 \leq 9\}$$

and

$$f: \mathbb{R}^3 \rightarrow \mathbb{R}, \quad (x, y, z) \mapsto xz + y(y - 1).$$

As  $K$  is compact and  $f$  is continuous,  $f$  attains both a minimum and a maximum on  $K$ . We want to determine those values and the points in  $K$  where they are attained.

We first consider the interior of  $K$ . Since

$$\frac{\partial f}{\partial x} = z, \quad \frac{\partial f}{\partial y} = 2y - 1, \quad \text{and} \quad \frac{\partial f}{\partial z} = x,$$

the only stationary point of  $f$  in the interior of  $K$  is  $(0, \frac{1}{2}, 0)$ . Since

$$(\text{Hess } f) \left( 0, \frac{1}{2}, 0 \right) = \begin{bmatrix} 0 & 0 & 1 \\ 0 & 2 & 0 \\ 1 & 0 & 0 \end{bmatrix},$$

the Hessian is neither positive nor negative definite (the element in the upper left corner is zero). The Hessian has rank three—and thus is invertible—so it must be indefinite. Hence,  $f$  has a saddle at  $(0, \frac{1}{2}, 0)$ .

To investigate the boundary of  $K$ , we apply the **Lagrange Multiplier Theorem**. Let

$$\phi: \mathbb{R}^3 \rightarrow \mathbb{R}, \quad (x, y, z) \mapsto x^2 + 4y^2 + z^2 - 9,$$

so that  $\partial K = \{(x, y, z) \in \mathbb{R}^3 : \phi(x, y, z) = 0\}$ . We have to find solutions to the equations

$$z = 2\lambda x, \quad (5.8)$$

$$2y - 1 = 8\lambda y, \quad (5.9)$$

$$x = 2\lambda z, \quad (5.10)$$

and

$$x^2 + 4y^2 + z^2 = 9. \quad (5.11)$$

Plugging (5.10) into (5.8), we obtain  $z = 4\lambda^2 z$ .

*Case 1:*  $z \neq 0$ . It follows that  $\lambda^2 = 1/4$ , so that  $\lambda = \pm 1/2$ .

*Subcase 1.1:*  $\lambda = 1/2$ . Then (5.8) (or (5.10)) yields  $x = z$ . Moreover, (5.9) yields  $2y - 1 = 4y$  and thus  $2y = -1$ , i.e.  $y = -1/2$ . Plugging into (5.11), we obtain  $2x^2 + 1 = 9$ , i.e.  $x = \pm 2$ . Possible points on  $\partial K$  where  $f$  could attain a minimum or a maximum are therefore  $(2, -\frac{1}{2}, 2)$  and  $(-2, -\frac{1}{2}, -2)$ . The values attained at those points are

$$f\left(2, -\frac{1}{2}, 2\right) = f\left(-2, -\frac{1}{2}, -2\right) = \frac{19}{4}.$$

*Subcase 1.2:*  $\lambda = -1/2$ . Then (5.8) yields  $x = -z$ . Moreover, (5.9) yields  $2y - 1 = -4y$  and thus  $6y = 1$ , i.e.  $y = 1/6$ . Plugging into (5.11), we obtain  $2x^2 + \frac{1}{9} = 9$ , i.e.  $x = \pm \frac{2\sqrt{10}}{3}$ . Candidates for points where  $f$  could attain a minimum or a maximum are therefore  $\left(\frac{2\sqrt{10}}{3}, \frac{1}{6}, -\frac{2\sqrt{10}}{3}\right)$  and  $\left(-\frac{2\sqrt{10}}{3}, \frac{1}{6}, \frac{2\sqrt{10}}{3}\right)$ . The values attained at those points are

$$f\left(\frac{2\sqrt{10}}{3}, \frac{1}{6}, -\frac{2\sqrt{10}}{3}\right) = f\left(-\frac{2\sqrt{10}}{3}, \frac{1}{6}, \frac{2\sqrt{10}}{3}\right) = -\frac{165}{36}.$$

*Case 2:*  $z = 0$ . Then (5.10) yields that  $x = 0$  as well. From (5.11), we obtain that  $4y^2 = 9$ , i.e.  $y = \pm 3/2$ . Therefore  $(0, \frac{3}{2}, 0)$  and  $(0, -\frac{3}{2}, 0)$  are also candidates for points where an extremum could be attained. The corresponding values achieved by  $f$  at those points are

$$f\left(0, \frac{3}{2}, 0\right) = \frac{3}{4} \quad \text{and} \quad f\left(0, -\frac{3}{2}, 0\right) = \frac{15}{4}.$$

Thus,  $f$  attains on  $K$  the minimum  $-165/36$  at  $\left(\frac{2\sqrt{10}}{3}, \frac{1}{6}, -\frac{2\sqrt{10}}{3}\right)$  and  $\left(-\frac{2\sqrt{10}}{3}, \frac{1}{6}, \frac{2\sqrt{10}}{3}\right)$  and the maximum  $19/4$  at  $(2, -\frac{1}{2}, 2)$  and  $(-2, -\frac{1}{2}, -2)$ .

### Exercises

1. Determine the maximum and the minimum of

$$f: \mathbb{R}^2 \rightarrow \mathbb{R}, \quad (x, y) \mapsto (x - 1)^2 + y^2$$

on

$$K := \{(x, y) \in \mathbb{R}^2 : x^2 + y^2 \leq 4\}.$$

as well as all points at which they are attained.

2. Determine the maximum and the minimum of

$$f: \mathbb{R}^2 \rightarrow \mathbb{R}, \quad (x, y) \mapsto x^2 + y^2 + xy$$

on

$$K := \{(x, y) \in \mathbb{R}^2 : 2 \leq x^2 + y^2 \leq 8\}.$$

Also, find all points in  $K$ , where the maximum and the minimum, respectively, are attained.

3. Find the minimum and maximum of

$$f: \mathbb{R}^2 \rightarrow \mathbb{R}, \quad (x, y) \mapsto x^2 - y^2$$

on

$$K := \{(x, y) : x^2 + 2y^2 \leq 2\}$$

and determine all points in  $K$  where the minimum and the maximum, respectively, are attained.

4. Determine the minimum and maximum of the function

$$f: \mathbb{R}^2 \rightarrow \mathbb{R}, \quad (x, y) \mapsto e^{-xy}$$

on the ellipse  $\{(x, y) \in \mathbb{R}^2 : x^2 + 4y^2 \leq 1\}$  as well as all points where those are attained.

5. Determine the maximum and minimum of

$$f: \mathbb{R}^3 \rightarrow \mathbb{R}, \quad (x, y, z) \mapsto xy + z^2$$

on

$$B := \{(x, y, z) \in \mathbb{R}^3 : x^2 + y^2 + z^2 \leq 2\}$$

as well as all the points at which they are attained.

6. Of course, the definition of a local extremum under a constraint can also be formulated with respect to a vector-valued function  $\phi$ . Prove the following generalization of the Lagrange multiplier theorem from class:

Let  $\emptyset \neq U \subset \mathbb{R}^N$  be open, let  $\phi \in C^1(U, \mathbb{R}^M)$  with  $M < N$ , let  $f \in C^1(U, \mathbb{R})$  have a local extremum at  $x_0 \in U$  under the constraint  $\phi(x) = 0$ , and suppose that  $J_\phi(x_0)$  has rank  $M$ . Then there exist  $\lambda_1, \dots, \lambda_M \in \mathbb{R}$  such that

$$(\nabla f)(x_0) = \sum_{j=1}^M \lambda_j (\nabla \phi_j)(x_0).$$

## 5.4 Change of Variables

In this section, we shall actually prove the change of variables formula stated earlier:

**Theorem 5.4.1** (Change of Variables). *Let  $\emptyset \neq U \subset \mathbb{R}^N$  be open, let  $\emptyset \neq K \subset U$  be compact with content, let  $\phi \in C^1(U, \mathbb{R}^N)$ , and suppose that there exists a set  $Z \subset K$  with content zero such that  $\phi|_{K \setminus Z}$  is injective and  $\det J_\phi(x) \neq 0$  for all  $x \in K \setminus Z$ . Then  $\phi(K)$  has content and*

$$\int_{\phi(K)} f = \int_K (f \circ \phi) |\det J_\phi|$$

holds for all continuous functions  $f: \phi(U) \rightarrow \mathbb{R}^M$ .

The reason why we didn't prove the theorem when we first encountered it were twofold: first of all, there simply wasn't enough time to both prove the theorem and cover applications, but secondly, the proof also requires some knowledge of local properties of  $C^1$ -functions, which wasn't available to us then.

Before we delve into the proof, we give yet another example:

*Example.* Let

$$D := \{(x, y) \in \mathbb{R}^2 : 1 \leq x^2 + y^2 \leq 4\}$$

and determine

$$\int_D \frac{1}{x^2 + y^2}.$$

Use polar coordinates:

$$\phi: \mathbb{R}^2 \rightarrow \mathbb{R}^2, \quad (r, \theta) \mapsto (r \cos \theta, r \sin \theta),$$

so that  $\det J_\phi(r, \theta) = r$ . Let  $K = [1, 2] \times [0, 2\pi]$ , so that  $\phi(K) = D$ . It follows that

$$\int_D \frac{1}{x^2 + y^2} = \int_K \frac{r}{r^2} = \int_K \frac{1}{r} = \int_1^2 \left( \int_0^{2\pi} \frac{1}{r} d\theta \right) dr = 2\pi \log 2.$$

To prove Theorem 5.4.1, we proceed through a series of steps.

Given a compact subset  $K$  of  $\mathbb{R}^N$  and a (sufficiently nice)  $C^1$ -function  $\phi$  on a neighborhood of  $K$ , we first establish that  $\phi(K)$  does indeed have content.

**Lemma 5.4.2.** *Let  $\emptyset \neq U \subset \mathbb{R}^N$  be open, let  $\phi \in C^1(U, \mathbb{R}^N)$ , and let  $K \subset U$  be compact with content zero. Then  $\phi(K)$  is compact with content zero.*

*Proof.* From the continuity of  $\phi$ , we know that  $\phi(K)$  is compact.

Choose an open set  $V \subset \mathbb{R}^N$  with  $K \subset V$ , and such that  $\bar{V} \subset U$  is compact.

As  $\phi$  is a  $C^1$ -function, the map

$$U \times \mathbb{R}^N \rightarrow \mathbb{R}, \quad (x, \xi) \mapsto \|J_\phi(x)\xi\|$$

is continuous; in particular, it is bounded on  $\bar{V} \times B_1[0]$ , so that there exists  $C > 0$  such that  $\|J_\phi(x)\xi\| \leq C$  for all  $x \in \bar{V}$  and all  $\xi \in \mathbb{R}^N$  with  $\|\xi\| \leq 1$ . It follows that

$$\|J_\phi(x)\xi\| \leq C\|\xi\| \tag{5.12}$$

for all  $x \in \bar{V}$  and all  $\xi \in \mathbb{R}^N$ .

Let  $\epsilon > 0$ , and choose compact intervals  $I_1, \dots, I_n \subset V$  with

$$K \subset \bigcup_{j=1}^n I_j \quad \text{and} \quad \sum_{j=1}^n \mu(I_j) < \frac{\epsilon}{(2C\sqrt{N})^N}.$$

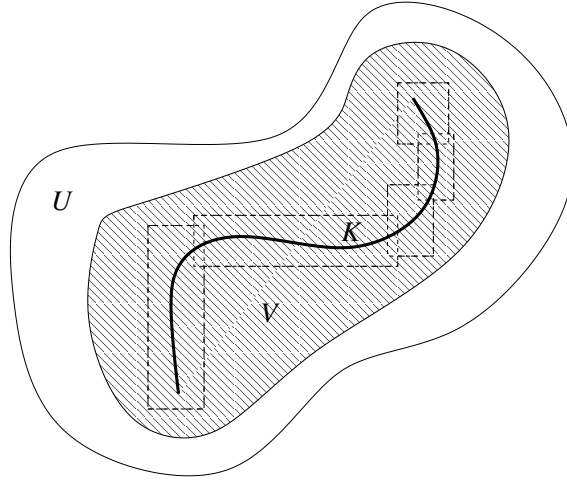

Figure 5.3:  $K$ ,  $U$ ,  $V$ , and  $I_1, \dots, I_n$

Without loss of generality, suppose that each  $I_j$  is a *cube*, i.e.,

$$I_j = [x_{j,1} - r_j, x_{j,1} + r_j] \times \cdots \times [x_{j,N} - r_j, x_{j,N} + r_j]$$

with  $(x_{j,1}, \dots, x_{j,N}) \in \mathbb{R}^N$  and  $r_j > 0$ : this can be done by first making sure that each  $I_j$  is of the form

$$I_j = [a_1, b_1] \times \cdots \times [a_N, b_N]$$



with  $a_1, b_1, \dots, a_N, b_N \in \mathbb{Q}$ , so that the ratios between the lengths of the different sides of  $I_j$  are rational, and then splitting it into sufficiently many cubes.

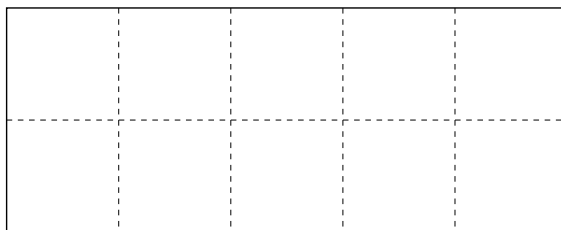

Figure 5.4: Splitting a 2-dimensional interval into cubes

(You're asked to work out the details in Exercise 1 below.)

Let  $j \in \{1, \dots, n\}$  and  $x, y \in I_j$ . Introducing

$$f : \mathbb{R} \rightarrow \mathbb{R}^n, \quad t \mapsto \phi(x + t(y - x)),$$

we see that  $\phi(y) - \phi(x) = f(1) - f(0) = \int_0^1 f'(t) dt$ , where  $f'(t) = J_\phi(x + t(y - x))(y - x)$ . Then for  $k = 1, \dots, N$ ,

$$\begin{aligned} |\phi_k(y) - \phi_k(x)| &\leq \|\phi(y) - \phi(x)\| = \left\| \int_0^1 J_\phi(x + t(y - x))(y - x) dt \right\| \\ &\leq \int_0^1 \|J_\phi(x + t(y - x))(y - x)\| dt \\ &\leq \int_0^1 C \|x - y\| dt = C \|x - y\|, \quad \text{by (5.12),} \\ &\leq C \sqrt{N(2r_j)^2} = C\sqrt{N} \mu(I_j)^{\frac{1}{N}} \doteq R_j. \end{aligned}$$

Fix  $x_0 \in I_j$ , let  $R_j := C\sqrt{N} \mu(I_j)^{\frac{1}{N}}$ , and define

$$J_j := [\phi_1(x_0) - R_j, \phi_1(x_0) + R_j] \times \cdots \times [\phi_N(x_0) - R_j, \phi_N(x_0) + R_j].$$

It follows that  $\phi(I_j) \subset J_j$ , with

$$\mu(J_j) = (2R_j)^N = (2C\sqrt{N})^N \mu(I_j).$$

Thus

$$\phi(K) \subset \bigcup_{j=1}^n J_j, \quad \text{where} \quad \sum_{j=1}^n \mu(J_j) = (2C\sqrt{N})^N \sum_{j=1}^n \mu(I_j) < \epsilon.$$

Hence,  $\phi(K)$  has content zero. □

**Lemma 5.4.3.** *Let  $\emptyset \neq U \subset \mathbb{R}^N$  be open, let  $\phi \in C^1(U, \mathbb{R}^N)$  be such that  $\det J_\phi(x) \neq 0$  for all  $x \in U$ , and let  $\emptyset \neq K \subset U$  be compact. Then*

$$\{x \in K : \phi(x) \in \partial\phi(K)\} \subset \partial K.$$

*In particular,  $\partial\phi(K) \subset \phi(\partial K)$ .*

*Proof.* Let  $x \in K$  be such that  $\phi(x) \in \partial\phi(K)$ , and let  $V \subset U$  be an open neighborhood of  $x$ , so that  $V \cap K \neq \emptyset$ . By Lemma 5.1.5,  $\phi(V)$  is a neighborhood of  $\phi(x)$ , and since  $\phi(x) \in \partial\phi(K)$ , it follows that  $\phi(V) \cap (\mathbb{R}^N \setminus \phi(K)) \neq \emptyset$ . Consequently,  $V \cap (\mathbb{R}^N \setminus K) \neq \emptyset$ . Thus  $x \in \partial K$ .

Since  $\phi(K)$  is compact and therefore closed, we have  $\partial\phi(K) \subset \phi(K)$  and thus  $\partial\phi(K) \subset \phi(\partial K)$ .  $\square$

**Proposition 5.4.4.** *Let  $\emptyset \neq U \subset \mathbb{R}^N$  be open, let  $\phi \in C^1(U, \mathbb{R}^N)$  be such that  $\det J_\phi(x) \neq 0$  for all  $x \in U$ , and let  $\emptyset \neq K \subset U$  be compact with content. Then  $\phi(K)$  is compact with content.*

*Proof.* Since  $K$  has content, Theorem 4.2.11 implies that  $\partial K$  has content zero. From Lemma 5.4.2, we conclude that  $\mu(\phi(\partial K)) = 0$ . Since  $\partial\phi(K) \subset \phi(\partial K)$  by Lemma 5.4.3, it follows that  $\mu(\partial\phi(K)) = 0$ . Using Theorem 4.2.11 again, we see that  $\phi(K)$  has content.  $\square$

Next, we investigate how applying a  $C^1$ -function to a set with content affects that content.

**Lemma 5.4.5.** *Let  $D \subset \mathbb{R}^N$  have content. Then*

$$\mu(D) = \inf \sum_{j=1}^n \mu(I_j), \quad (5.13)$$

*where the infimum is taken over all  $n \in \mathbb{N}$  and all compact intervals  $I_1, \dots, I_n \subset \mathbb{R}^N$  such that  $D \subset I_1 \cup \dots \cup I_n$ .*

*Proof.* See Exercise 2 below.  $\square$

**Proposition 5.4.6.** *Let  $\emptyset \neq K \subset \mathbb{R}^N$  be compact with content, and let  $T: \mathbb{R}^N \rightarrow \mathbb{R}^N$  be linear. Then  $T(K)$  has content such that*

$$\mu(T(K)) = |\det T| \mu(K).$$

*Proof.* We first prove three separate cases of the claim:

*Case 1:*

$$T(x_1, \dots, x_N) = (x_1, \dots, \lambda x_j, \dots, x_N)$$

with  $\lambda \in \mathbb{R}$  for  $x_1, \dots, x_N \in \mathbb{R}$ .

Suppose first that  $K$  is an interval, say  $K = [a_1, b_1] \times \cdots \times [a_N, b_N]$ , so that

$$T(K) = [a_1, b_1] \times \cdots \times [\lambda a_j, \lambda b_j] \times \cdots \times [a_N, b_N]$$

if  $\lambda \geq 0$  and

$$T(K) = [a_1, b_1] \times \cdots \times [\lambda b_j, \lambda a_j] \times \cdots \times [a_N, b_N]$$

if  $\lambda < 0$ . Since  $\det T = \lambda$ , this settles the claim in this particular case.

Suppose that  $K$  is now arbitrary and  $\lambda \neq 0$ . Then  $T$  is invertible, so that  $T(K)$  has content by Proposition 5.4.4. For any closed intervals  $I_1, \dots, I_n \subset \mathbb{R}^N$  with  $K \subset I_1 \cup \dots \cup I_n$ , we then obtain

$$\mu(T(K)) \leq \sum_{j=1}^n \mu(T(I_j)) = |\det T| \sum_{j=1}^n \mu(I_j)$$

and thus  $\mu(T(K)) \leq |\det T| \mu(K)$  by Lemma 5.4.5. Since  $T^{-1}$  is of the same form, we get also get  $\mu(K) = \mu(T^{-1}(T(K))) \leq |\det T|^{-1} \mu(T(K))$  and thus  $\mu(T(K)) \geq |\det T| \mu(K)$ .

For arbitrary  $K$  and  $\lambda = 0$ , let  $I \subset \mathbb{R}^N$  be a compact interval with  $K \subset I$ . Then  $T(I)$  and  $T(K) \subset T(I)$  have content zero.

*Case 2:*

$$T(x_1, \dots, x_j, \dots, x_k, \dots, x_N) = (x_1, \dots, x_k, \dots, x_j, \dots, x_N)$$

with  $j < k$  for  $x_1, \dots, x_N \in \mathbb{R}$ . Again,  $T$  is invertible, so that  $T(K)$  has content by Proposition 5.4.4. Since  $\det T = -1$ , the claim is trivially true if  $K$  is an interval and for general  $K$  by Lemma 5.4.5 in a way similar to Case 1.

*Case 3:*

$$T(x_1, \dots, x_j, \dots, x_k, \dots, x_N) = (x_1, \dots, x_j, \dots, x_k + x_j, \dots, x_N)$$

with  $j < k$  for  $x_1, \dots, x_N \in \mathbb{R}$ . Again,  $T$  is invertible, so that  $T(K)$  has content by Proposition 5.4.4. Suppose first that  $K$  is a compact interval. As only the two coordinates  $j$  and  $k$  are involved, it follows from a straightforward application of Fubini's Theorem, that we can limit ourselves to the case where  $j = 1$  and  $k = N = 2$ . Let  $K = [a, b] \times [c, d]$ , so that

$$\begin{aligned} T(K) &= \{(x, x + y) \in \mathbb{R}^2 : x \in [a, b], y \in [c, d]\} \\ &= \{(x, y) \in \mathbb{R}^2 : x \in [a, b], c + x \leq y \leq d + x\}. \end{aligned}$$

Applying Fubini's Theorem again, we obtain

$$\begin{aligned}\mu(T(K)) &= \int_a^b \int_{c+x}^{d+x} 1 \, dy \, dx \\ &= \int_a^b (d-c) \, dx \\ &= (b-a)(d-c) \\ &= \mu(K).\end{aligned}$$

Since  $\det T = 1$ , this settles the claim in this case.

Now, let  $K$  be arbitrary. Invoking Lemma 5.4.5 as in Case 1, we obtain  $\mu(T(K)) \leq \mu(K)$ . Obtaining the reversed inequality is a little bit harder than in Cases 1 and 2 because  $T^{-1}$  is not of the form covered by Case 3 (in fact, it isn't covered by any of Cases 1, 2, and 3). Let  $S: \mathbb{R}^N \rightarrow \mathbb{R}^N$  be defined by

$$S(x_1, \dots, x_j, \dots, x_N) = (x_1, \dots, -x_j, \dots, x_N).$$

It follows that  $T^{-1} = S \circ T \circ S$ , so that—in view of Case 1—we get

$$\begin{aligned}\mu(K) &= \mu(T^{-1}(T(K))) \\ &= \mu(S(T(S(T(K)))))) = \mu(T(S(T(K)))) \leq \mu(S(T(K))) = \mu(T(K)),\end{aligned}$$

so that  $\mu(T(K)) = \mu(K)$ .

Suppose now that  $T$  is arbitrary. Then there are linear maps  $T_1, \dots, T_n: \mathbb{R}^N \rightarrow \mathbb{R}^N$  such that  $T = T_1 \circ \dots \circ T_n$ , and each  $T_j$  is of one of the forms discussed in Cases 1, 2, and 3. We therefore eventually obtain

$$\begin{aligned}\mu(T(K)) &= \mu(T_1(\dots T_n(K) \dots)) \\ &= |\det T_1| \mu(T_2(\dots T_n(K) \dots)) = \dots = |\det T_1| \dots |\det T_n| \mu(K) = |\det T| \mu(K).\end{aligned}$$

This completes the proof. □

Next, we move from linear maps to  $\mathcal{C}^1$ -maps:

**Lemma 5.4.7.** *Let  $U \subset \mathbb{R}^N$  be open, let  $r > 0$  be such that  $K := [-r, r]^N \subset U$ , and let  $\phi \in \mathcal{C}^1(U, \mathbb{R}^N)$  be such that  $\det J_\phi(x) \neq 0$  for all  $x \in U$ . Furthermore, suppose that  $\epsilon \in (0, 1)$  is such that  $\|\phi(x) - x\| \leq \frac{\epsilon}{\sqrt{N}} \|x\|$  for  $x \in K$ . Then*

$$(1 - \epsilon)^N \leq \frac{\mu(\phi(K))}{\mu(K)} \leq (1 + \epsilon)^N.$$

*Proof.* Let  $x \in K$ . Then

$$\|\phi(x) - x\| \leq \frac{\epsilon}{\sqrt{N}} \|x\| \leq \epsilon r;$$

consequently,

$$|\phi_j(x)| \leq |x_j| + \|\phi(x) - x\| \leq (1 + \epsilon)r$$

for  $j = 1, \dots, N$ . This means that

$$\phi(K) \subset [-(1 + \epsilon)r, (1 + \epsilon)r]^N. \quad (5.14)$$

Let  $x = (x_1, \dots, x_N) \in \partial K$ , so that  $|x_j| = r$  for some  $j \in \{1, \dots, N\}$ . Consequently,

$$r = |x_j| \leq \|x\| \leq \sqrt{N}r$$

and thus

$$|\phi_j(x)| \geq |x_j| - \|x - \phi(x)\| \geq (1 - \epsilon)r.$$

Since  $\partial\phi(K) \subset \phi(\partial K)$  by Lemma 5.4.3, this means that

$$\partial\phi(K) \subset \phi(\partial K) \subset \mathbb{R}^N \setminus (-(1 - \epsilon)r, (1 - \epsilon)r)^N$$

and thus

$$(-(1 - \epsilon)r, (1 - \epsilon)r)^N \subset \mathbb{R}^N \setminus \partial\phi(K).$$

Let  $U := \text{int } \phi(K)$  and  $V := \text{int } (\mathbb{R}^N \setminus \phi(K))$ . Then  $U$  and  $V$  are open, disjoint, non-empty, and satisfy

$$U \cup V = \mathbb{R}^N \setminus \partial\phi(K).$$

Since  $(-(1 - \epsilon)r, (1 - \epsilon)r)^N$  is connected, this means that it is contained either in  $U$  or in  $V$  because otherwise  $\{U, V\}$  would be a disconnection for it. Since

$$\|\phi(0)\| = \|\phi(0) - 0\| \leq \frac{\epsilon}{\sqrt{N}}\|0\| = 0,$$

it follows that  $0 \in (-(1 - \epsilon)r, (1 - \epsilon)r)^N \cap U$  and thus

$$(-(1 - \epsilon)r, (1 - \epsilon)r)^N \subset U \subset \phi(K). \quad (5.15)$$

From (5.14) and (5.15), we conclude that

$$(1 - \epsilon)^N (2r)^N \leq \mu(\phi(K)) \leq (1 + \epsilon)^N (2r)^N.$$

Division by  $\mu(K) = (2r)^N$  yields the claim.  $\square$

For  $x = (x_1, \dots, x_N) \in \mathbb{R}^N$  and  $r > 0$ , we denote by

$$C[x, r] := [x_1 - r, x_1 + r] \times \dots \times [x_N - r, x_N + r]$$

the cube with center  $x$  and side length  $2r$ .

**Proposition 5.4.8.** *Let  $\emptyset \neq U \subset \mathbb{R}^N$  be open and  $\phi \in C^1(U, \mathbb{R}^N)$  be such that  $\det J_\phi(x) \neq 0$  for all  $x \in U$ . Then for each compact set  $\emptyset \neq K \subset U$  and  $\epsilon \in (0, 1)$ , there exists  $r_\epsilon > 0$  such that for all  $x \in K$  and all  $r \in (0, r_\epsilon)$  we have  $C[x, r] \subset U$  and*

$$|\det J_\phi(x)|(1 - \epsilon)^N \leq \frac{\mu(\phi(C[x, r]))}{\mu(C[x, r])} \leq |\det J_\phi(x)|(1 + \epsilon)^N.$$

*Proof.* Let  $M > 0$  be such that

$$\|J_\phi(x)^{-1}\xi\| \leq M\|\xi\|$$

for all  $x \in K$  and  $\xi \in \mathbb{R}^N$ . Given  $\epsilon \in (0, 1)$ , choose  $r_\epsilon > 0$  such that  $C[x + \xi, r_\epsilon] \subset U$  and

$$\|\phi(x + \xi) - \phi(x) - J_\phi(x)\xi\| \leq \frac{\epsilon}{M\sqrt{N}}\|\xi\|$$

for all  $x \in K$  and  $\xi \in C[0, r_\epsilon]$ . Fix  $x \in K$  and define

$$\psi(\xi) := J_\phi(x)^{-1}(\phi(x + \xi) - \phi(x)).$$

For  $r \in (0, r_\epsilon)$ , we thus have

$$\|\psi(\xi) - \xi\| = \|J_\phi(x)^{-1}(\phi(x + \xi) - \phi(x) - J_\phi(x)\xi)\| \leq M\|\phi(x + \xi) - \phi(x) - J_\phi(x)\xi\| \leq \frac{\epsilon}{\sqrt{N}}\|\xi\|$$

for  $\xi \in C[0, r]$ . From Lemma 5.4.7, we conclude that

$$(1 - \epsilon)^N \leq \frac{\mu(\psi(C[0, r]))}{\mu(C[0, r])} \leq (1 + \epsilon)^N. \quad (5.16)$$

Since

$$\psi(C[0, r]) = J_\phi(x)^{-1}\phi(C[x, r]) - J_\phi(x)^{-1}\phi(x),$$

Proposition 5.4.6 yields

$$\mu(\psi(C[0, r])) = \mu(J_\phi(x)^{-1}\phi(C[x, r])) = |\det J_\phi(x)^{-1}|\mu(\phi(C[x, r])).$$

On multiplying (5.16) by  $|\det J_\phi(x)|$  and noting  $\mu(C[0, r]) = \mu(C[x, r])$  we obtain

$$|\det J_\phi(x)|(1 - \epsilon)^N \leq \frac{\mu(\phi(C[x, r]))}{\mu(C[x, r])} \leq |\det J_\phi(x)|(1 + \epsilon)^N,$$

as claimed.  $\square$

We can now prove:

**Theorem 5.4.9.** *Let  $\emptyset \neq U \subset \mathbb{R}^N$  be open,  $\emptyset \neq K \subset U$  be compact with content, and  $\phi \in C^1(U, \mathbb{R}^N)$  be injective on  $K$  such that  $\det J_\phi(x) \neq 0$  for all  $x \in K$ . Then  $\phi(K)$  has content and*

$$\int_{\phi(K)} f = \int_K (f \circ \phi) |\det J_\phi| \quad (5.17)$$

for all continuous functions  $f: \phi(U) \rightarrow \mathbb{R}^M$ .

*Proof.* Let  $f: \phi(U) \rightarrow \mathbb{R}^M$  be continuous. By Proposition 5.4.4,  $\phi(K)$  has content. Hence, both integrals in (5.17) exist, and we are left with showing that they are equal.

Suppose without loss of generality that  $M = 1$ . Since

$$f = \underbrace{\frac{1}{2}(f + |f|)}_{\geq 0} - \underbrace{\frac{1}{2}(|f| - f)}_{\geq 0},$$

we can also suppose that  $f \geq 0$ .

For each  $x \in K$ , choose  $U_x \subset U$  open with  $x \in U_x$  and  $\det J_\phi(y) \neq 0$  for all  $y \in U_x$ . Since  $\{U_x : x \in K\}$  is an open cover of  $K$ , there exist  $x_1, \dots, x_\ell \in K$  with

$$K \subset U_{x_1} \cup \dots \cup U_{x_\ell}.$$

Replacing  $U$  by  $U_{x_1} \cup \dots \cup U_{x_\ell}$ , we can thus suppose that  $\det J_\phi(x) \neq 0$  for all  $x \in U$ .

Let  $\epsilon \in (0, 1)$ , and choose compact intervals  $I_1, \dots, I_n \subset U$  with  $I_j \cap K \neq \emptyset$  and the following properties:

- (a) for  $j \neq k$ , the intervals  $I_j$  and  $I_k$  have only boundary points in common, and we have  $K \subset \bigcup_{j=1}^n I_j \subset U$ ;
- (b) if  $m \leq n$  is such that  $I_j \cap \partial K \neq \emptyset$  if and only if  $j \in \{1, \dots, m\}$ , then  $\sum_{j=1}^m \mu(I_j) < \epsilon$  holds (this is possible because  $\mu(\partial K) = 0$ );
- (c') for any choice of  $\xi_j, \eta_j \in I_j$  for  $j = 1, \dots, n$  we have

$$\left| \int_K (f \circ \phi) |\det J_\phi| - \sum_{j=1}^n (f \circ \phi)(\xi_j) |\det J_\phi(\eta_j)| \mu(I_j) \right| < \epsilon;$$

(see Exercise 3 below). Arguing as in the proof of Lemma 5.4.2, we can suppose that  $I_1, \dots, I_n$  are actually cubes with centers  $x_1, \dots, x_n$ , respectively. From (c'), we then obtain

$$(c) \quad \left| \int_K (f \circ \phi) |\det J_\phi| - \sum_{j=1}^n (f \circ \phi)(\xi_j) |\det J_\phi(x_j)| \mu(I_j) \right| < \epsilon.$$

for any choice of  $\xi_j \in I_j$  for  $j = 1, \dots, n$  (see again Exercise 3 below).

Making our cubes even smaller, in view of Proposition 5.4.8, we can also suppose that

$$(d) \quad |\det J_\phi(x_j)| (1 - \epsilon)^N \leq \frac{\mu(\phi(I_j))}{\mu(I_j)} \leq |\det J_\phi(x_j)| (1 + \epsilon)^N$$

for  $j = 1, \dots, n$ .

Let  $V \subset U$  be open and bounded such that

$$\bigcup_{j=1}^n I_j \subset V \subset \bar{V} \subset U,$$

and let  $C := \sup\{|\det J_\phi(x)| : x \in \bar{V}\}$ . Together, (b) and (d) yield

$$\sum_{j=1}^m \mu(\phi(I_j)) \leq 2^N C \epsilon.$$

If  $m = n$  let  $S = \emptyset$ ; otherwise let  $S = \bigcup_{j=m+1}^n I_j$ . For each  $j \in \{m+1, \dots, n\}$ , we know that  $I_j \cap \partial K = \emptyset$ , but  $I_j \cap K \neq \emptyset$ . As in the proof of Lemma 5.4.7, the connectedness of  $I_j$  yields  $I_j \subset K$ . Thanks to the injectivity of  $\phi$  on  $K$ , we know that

$$\phi(K) \setminus \phi(S) = \phi(K \setminus S).$$

Let  $\tilde{C} := \sup\{|f(\phi(x))| : x \in \bar{V}\}$ , and note that

$$\begin{aligned} \left| \int_{\phi(K)} f - \sum_{j=1}^n \int_{\phi(I_j)} f \right| &\leq \left| \int_{\phi(K)} f - \sum_{j=m+1}^n \int_{\phi(I_j)} f \right| + \left| \sum_{j=1}^m \int_{\phi(I_j)} f \right| \\ &\leq \int_{\phi(K) \setminus \phi(S)} f + 2^N C \tilde{C} \epsilon = \int_{\phi(K \setminus S)} f + 2^N C \tilde{C} \epsilon \\ &\leq \int_{\phi(\bigcup_{j=1}^m I_j)} f + 2^N C \tilde{C} \epsilon \\ &\leq 2^{N+1} C \tilde{C} \epsilon. \end{aligned} \quad (5.18)$$

Let  $j \in \{1, \dots, n\}$ . Since the set  $\phi(I_j)$  is connected, there exists  $y_j \in \phi(I_j)$  such that  $\int_{\phi(I_j)} f = f(y_j) \mu(\phi(I_j))$ ; choose  $\xi_j \in I_j$  such that  $y_j = \phi(\xi_j)$ . It follows that

$$\sum_{j=1}^n \int_{\phi(I_j)} f = \sum_{j=1}^n f(y_j) \mu(\phi(I_j)) = \sum_{j=1}^n f(\phi(\xi_j)) \mu(\phi(I_j)). \quad (5.19)$$

Since  $f \geq 0$ , we obtain from (d) and (5.19) that

$$\begin{aligned} \sum_{j=1}^n f(\phi(\xi_j)) |\det J_\phi(x_j)| \mu(I_j) (1 - \epsilon)^N &\leq \sum_{j=1}^n f(\phi(\xi_j)) \mu(\phi(I_j)) = \sum_{j=1}^n \int_{\phi(I_j)} f \\ &\leq \sum_{j=1}^n f(\phi(\xi_j)) |\det J_\phi(x_j)| \mu(I_j) (1 + \epsilon)^N. \end{aligned} \quad (5.20)$$

As  $\epsilon \rightarrow 0$ , the right- and left-hand sides of (5.20) converge to the right-hand side of (5.17) by (c), whereas (5.19) converges to the left-hand side of (5.17) by (5.18).  $\square$

Even though Theorem 5.4.9 almost looks like the Change of Variables Theorem, it is still not general enough to cover polar, spherical, or cylindrical coordinates.



*Proof of Theorem 5.4.1.* We leave showing that  $\phi(K)$  has content to an exercise (see below).

Let  $\epsilon > 0$ , and let  $C > 0$  be such that

$$C \geq \sup\{|f(\phi(x)) \det J_\phi(x)|, |f(\phi(x))| : x \in K\}.$$

Choose compact intervals  $I_1, \dots, I_n \subset U$  and  $J_1, \dots, J_n \subset \mathbb{R}^N$  such that  $\phi(I_j) \subset J_j$  for  $j = 1, \dots, n$ ,

$$Z \subset \bigcup_{j=1}^n \text{int } I_j, \quad \sum_{j=1}^n \mu(I_j) < \frac{\epsilon}{2C}, \quad \text{and} \quad \sum_{j=1}^n \mu(J_j) < \frac{\epsilon}{2C}.$$

Let  $K_0 := K \setminus \bigcup_{j=1}^n \text{int } I_j$ . Then  $K_0$  is compact,  $\phi|_{K_0}$  is injective and  $\det J_\phi(x) \neq 0$  for  $x \in K_0$ . From Theorem 5.4.9, we conclude that

$$\int_{\phi(K_0)} f = \int_{K_0} (f \circ \phi) |\det J_\phi|.$$

From the choice of the intervals  $I_j$ , it follows that

$$\left| \int_K (f \circ \phi) |\det J_\phi| - \int_{K_0} (f \circ \phi) |\det J_\phi| \right| < \frac{\epsilon}{2},$$

and since  $\phi(K) \setminus \phi(K_0) \subset J_1 \cup \dots \cup J_n$ , the choice of  $J_1, \dots, J_n$  yields

$$\left| \int_{\phi(K)} f - \int_{\phi(K_0)} f \right| < \frac{\epsilon}{2}.$$

We thus conclude that

$$\left| \int_{\phi(K)} f - \int_K (f \circ \phi) |\det J_\phi| \right| < \epsilon.$$

Since  $\epsilon > 0$  is arbitrary, this completes the proof.  $\square$

*Example.* Let  $D \subset \mathbb{R}^3$  be the region lying above the  $xy$  plane, below the upper hemisphere of a ball centered at 0 with radius  $R > 0$ , and within the cylinder described by

$$x^2 - Rx + y^2 = 0. \tag{5.21}$$

What is the volume of  $D$ ?

First note that

$$\begin{aligned} x^2 - Rx + y^2 = 0 &\iff x^2 - 2\frac{R}{2}x + \frac{R^2}{4} + y^2 = \frac{R^2}{4} \\ &\iff \left(x - \frac{R}{2}\right)^2 + y^2 = \frac{R^2}{4}. \end{aligned}$$

Restricted to the  $xy$  plane, (5.21) describes a circle centered at  $(\frac{R}{2}, 0)$  with radius  $\frac{R}{2}$ . It follows that

$$D = \{(x, y, z) \in \mathbb{R}^3 : x^2 + y^2 + z^2 \leq R^2, z \geq 0, x^2 + y^2 \leq Rx\}.$$

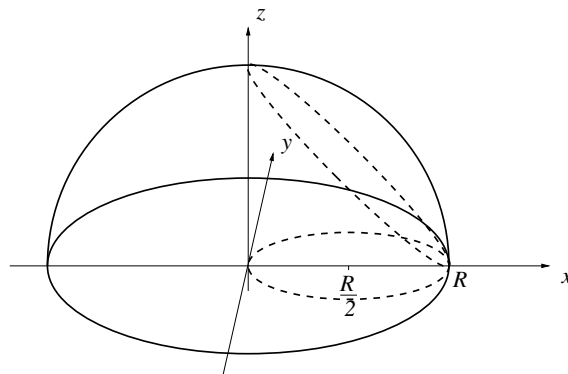

Figure 5.5: Intersection of a solid hemisphere with a cylinder

Use cylindrical coordinates, i.e.,

$$\phi: \mathbb{R}^3 \rightarrow \mathbb{R}^3, \quad (r, \theta, z) \mapsto (r \cos \theta, r \sin \theta, z).$$

Since for  $r > 0$

$$\begin{aligned} x^2 + y^2 \leq Rx &\iff r^2 = r^2(\cos \theta)^2 + r^2(\sin \theta)^2 \leq Rr \cos \theta \\ &\iff r \leq R \cos \theta, \end{aligned}$$

it follows that  $D = \phi(K)$  with

$K :=$

$$\left\{ (r, \theta, z) \in [0, \infty) \times [-\pi, \pi] \times \mathbb{R} : \theta \in \left[-\frac{\pi}{2}, \frac{\pi}{2}\right], r \in [0, R \cos \theta], z \in [0, \sqrt{R^2 - r^2}] \right\}.$$

The Change of Variables Formula then yields

$$\begin{aligned}
\mu(D) &= \int_D 1 \\
&= \int_K (1 \circ \phi) |\det J_\phi| \\
&= \int_K r \\
&= \int_{-\frac{\pi}{2}}^{\frac{\pi}{2}} \left( \int_0^{R \cos \theta} \left( \int_0^{\sqrt{R^2 - r^2}} r \, dz \right) dr \right) d\theta \\
&= \int_{-\frac{\pi}{2}}^{\frac{\pi}{2}} \left( \int_0^{R \cos \theta} r \sqrt{R^2 - r^2} \, dr \right) d\theta \\
&= -\frac{1}{2} \int_{-\frac{\pi}{2}}^{\frac{\pi}{2}} \left( \int_0^{R \cos \theta} (-2r) \sqrt{R^2 - r^2} \, dr \right) d\theta \\
&= -\frac{1}{2} \int_{-\frac{\pi}{2}}^{\frac{\pi}{2}} \left( \int_{R^2}^{R^2 - R^2 (\cos \theta)^2} \sqrt{u} \, du \right) d\theta \\
&= \frac{1}{2} \int_{-\frac{\pi}{2}}^{\frac{\pi}{2}} \left( \int_{R^2 (\sin \theta)^2}^{R^2} \sqrt{u} \, du \right) d\theta \\
&= \frac{1}{2} \int_{-\frac{\pi}{2}}^{\frac{\pi}{2}} \frac{2}{3} u^{\frac{3}{2}} \Big|_{u=R^2 (\sin \theta)^2}^{u=R^2} d\theta \\
&= \frac{1}{3} \int_{-\frac{\pi}{2}}^{\frac{\pi}{2}} (R^3 - R^3 |\sin \theta|^3) d\theta \\
&= \frac{R^3}{3} \pi - \frac{R^3}{3} \int_{-\frac{\pi}{2}}^{\frac{\pi}{2}} |\sin \theta|^3 d\theta.
\end{aligned}$$

We perform an auxiliary calculation. First note that

$$\int_{-\frac{\pi}{2}}^{\frac{\pi}{2}} |\sin \theta|^3 d\theta = 2 \int_0^{\frac{\pi}{2}} (\sin \theta)^3 d\theta.$$

As

$$\begin{aligned}
 \int_0^{\frac{\pi}{2}} (\sin \theta)^3 d\theta &= \int_0^{\frac{\pi}{2}} (\sin \theta)(\sin \theta)^2 d\theta \\
 &= \int_0^{\frac{\pi}{2}} (\sin \theta)(1 - (\cos \theta)^2) d\theta \\
 &= \int_0^{\frac{\pi}{2}} \sin \theta d\theta + \int_0^{\frac{\pi}{2}} (-\sin \theta)(\cos \theta)^2 d\theta \\
 &= 1 + \int_1^0 u^2 du \\
 &= 1 - \int_0^1 u^2 du \\
 &= \frac{2}{3},
 \end{aligned}$$

it follows that

$$\int_{-\frac{\pi}{2}}^{\frac{\pi}{2}} |\sin \theta|^3 d\theta = \frac{4}{3}.$$

All in all, we obtain

$$\mu(D) = \frac{R^3}{3} \left( \pi - \frac{4}{3} \right).$$

### Exercises

1. An  $N$ -dimensional *cube* is a subset  $C$  of  $\mathbb{R}^N$  such that

$$C = [x_1 - r, x_1 + r] \times \cdots \times [x_N - r, x_N + r]$$

with  $x_1, \dots, x_N \in \mathbb{R}$  and  $r > 0$ .

Let  $\emptyset \neq U \subset \mathbb{R}^N$  be open and let  $Z \subset U$  be compact with content zero. Show that, for each  $\epsilon > 0$ , there are cubes  $C_1, \dots, C_n \subset U$  with

$$Z \subset C_1 \cup \cdots \cup C_n \quad \text{and} \quad \sum_{j=1}^n \mu(C_j) < \epsilon.$$

2. Let  $D \subset \mathbb{R}^N$  have content. Show that

$$\mu(D) = \inf \sum_{j=1}^n \mu(I_j)$$

holds, where the infimum on the right hand side is taken over all  $n \in \mathbb{N}$  and all compact intervals  $I_1, \dots, I_n \subset \mathbb{R}^N$  such that  $D \subset I_1 \cup \cdots \cup I_n$ .

3. Let  $I \subset \mathbb{R}^N$  be a compact interval, let  $f, g: I \rightarrow \mathbb{R}$  be continuous, and let  $\epsilon > 0$ . Show that there is a partition  $\mathcal{P}_\epsilon$  of  $I$  such that, for each refinement  $\mathcal{P}$  of  $\mathcal{P}_\epsilon$ , we have

$$\left| \int_I fg - \sum_\nu f(x_\nu)g(y_\nu)\mu(I_\nu) \right| < \epsilon,$$

where  $(I_\nu)_\nu$  is the subdivision of  $I$  corresponding to  $\mathcal{P}$  and  $x_\nu, y_\nu \in I_\nu$  are arbitrary.

4. Show that:

- (a) if  $D \subset \mathbb{R}^N$  has content, then so has  $\overline{D}$  such that  $\mu(\overline{D}) = \mu(D)$ ;  
 (b) if  $\emptyset \neq U \subset \mathbb{R}^N$  is open,  $Z$  is a set of content zero with  $\overline{Z} \subset U$ , and  $\phi: U \rightarrow \mathbb{R}^N$  is a  $\mathcal{C}^1$ -function, then  $\phi(Z)$  has content zero.

5. Let  $\emptyset \neq U \subset \mathbb{R}^N$  be open, let  $K \subset U$  be compact with content, let  $\phi \in \mathcal{C}^1(U, \mathbb{R}^N)$ , and suppose that there exists  $Z \subset K$  with content zero such that  $\det J_\phi(x) \neq 0$  for all  $x \in K \setminus Z$ . Show that  $\phi(K)$  has content. (*Hint*: Show that  $\partial\phi(K) \subset \phi(Z) \cup \phi(\partial K)$ .)
6. Let  $C$  be the cylinder standing perpendicularly on the  $xy$ -plane such that its intersection with that plane is the closed unit disc, and let  $P$  be the prism (extending from  $-\infty$  to  $\infty$  along the  $y$ -axis) standing perpendicularly on the  $xz$ -plane such that its intersection with that plane is the diamond given by  $|x| + |z| \leq 1$ . Compute the content of  $C \cap P$ .
7. We may identify  $\mathbb{C}$  with  $\mathbb{R}^2$ . For  $0 < \rho < R$ , let

$$A_{R,\rho} := \{z \in \mathbb{C} : \rho \leq |z| \leq R\}.$$

Calculate  $\int_{A_{R,\rho}} \frac{1}{z}$ .

8. Let  $\emptyset \neq K \subset \mathbb{R}^3$  be a compact body with content, and let  $\mu: K \rightarrow \mathbb{R}$  be a continuous density. The *Newton potential* generated by  $K$  at  $x_0 \in \mathbb{R}^3 \setminus K$  is given (up to a factor) by

$$u(x_0) := \int_K \frac{\mu(x)}{\|x_0 - x\|} dx.$$

Suppose that  $K = B_R[(0, 0, 0)]$  with  $R > 0$ , and that  $\mu$  is *rotation symmetric*, i.e., there exists a continuous function  $\tilde{\mu}: [0, R] \rightarrow \mathbb{R}$  such  $\mu(x) = \tilde{\mu}(\|x\|)$  for all  $x \in K$ . Show that

$$u(x_0) = \frac{1}{\|x_0\|} \int_K \mu.$$

for all  $x_0 \in \mathbb{R}^3 \setminus K$ . (*Hint*: First, argue that we can suppose that  $x_0 = (0, 0, \|x_0\|)$  without loss of generality; then use spherical coordinates.)

9. Show that a slice of pizza of radius  $r > 0$  and with angle  $\alpha$  has the area  $\frac{1}{2}r^2\alpha$ .

## Chapter 6

# Curve and Surface Integrals

### 6.1 Curves in $\mathbb{R}^N$

What is the circumference of a circle of radius  $r > 0$ ? Of course, we “know” the answer:  $2\pi r$ . But how can this be proven? More generally, what is the length of a curve in the plane, in space, or in general  $N$ -dimensional Euclidean space?

We first need a rigorous definition of a curve:

**Definition 6.1.1.** A *curve* in  $\mathbb{R}^N$  is a continuous map  $\gamma: [a, b] \rightarrow \mathbb{R}^N$ . The set  $\{\gamma\} := \gamma([a, b])$  is called the *trace* or *line element* of  $\gamma$ .

*Examples.*

1. For  $r > 0$ , let

$$\gamma: [0, 2\pi] \rightarrow \mathbb{R}^2, \quad t \mapsto (r \cos t, r \sin t).$$

Then  $\{\gamma\}$  is a circle centered at  $(0, 0)$  with radius  $r$ .

2. Let  $c, v \in \mathbb{R}^N$  with  $v \neq 0$ , and let

$$\gamma: [a, b] \rightarrow \mathbb{R}^N, \quad t \mapsto c + tv.$$

Then  $\{\gamma\}$  is the line segment from  $c + av$  to  $c + bv$ . Slightly abusing terminology, we will also call  $\gamma$  a line segment.

3. Let  $\gamma: [a, b] \rightarrow \mathbb{R}^N$  be a curve, and suppose that there exists a partition  $a = t_0 < t_1 < \dots < t_n = b$  such that  $\gamma|_{[t_{j-1}, t_j]}$  is a line segment for  $j = 1, \dots, n$ . Then  $\gamma$  is called a *polygonal path*: one can think of it as a concatenation of line segments.
4. For  $r > 0$  and  $s \neq 0$ , let

$$\gamma: [0, 6\pi] \rightarrow \mathbb{R}^3, \quad t \mapsto (r \cos t, r \sin t, st).$$

Then  $\{\gamma\}$  is a helix:

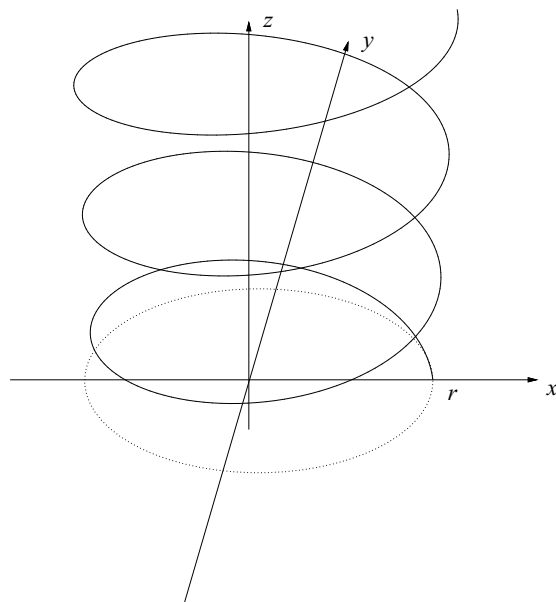

Figure 6.1: Helix

If  $\gamma: [a, b] \rightarrow \mathbb{R}^N$  is a line segment, it makes sense to define its length as  $\|\gamma(b) - \gamma(a)\|$ . It is equally intuitive how to define the length of a polygonal path: sum up the lengths of all the line segments it is made up of.

For more general curves, one tries to successively approximate them with polygonal paths:

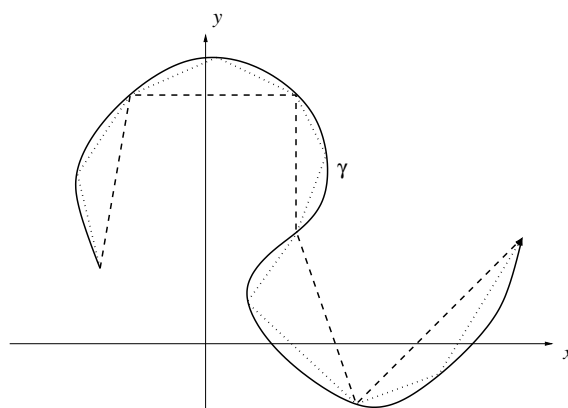

Figure 6.2: Successive approximation of a curve with polygonal paths

This motivates the following definition:

**Definition 6.1.2.** A curve  $\gamma: [a, b] \rightarrow \mathbb{R}^N$  is called *rectifiable* if

$$\left\{ \sum_{j=1}^n \|\gamma(t_j) - \gamma(t_{j-1})\| : n \in \mathbb{N}, a = t_0 < t_1 < \cdots < t_n = b \right\} \quad (6.1)$$

is bounded. The supremum of (6.1) is called the *length* of  $\gamma$ .

Even though this definition for the length of a curve is intuitive, it does not provide any effective means to calculate the length of a curve (except for polygonal paths).

**Lemma 6.1.3.** Let  $\gamma: [a, b] \rightarrow \mathbb{R}^N$  be a  $C^1$  curve. Then, for each  $\epsilon > 0$ , there exists  $\delta > 0$  such that

$$\left\| \frac{\gamma(t) - \gamma(s)}{t - s} - \gamma'(t) \right\| < \epsilon$$

for all  $s, t \in [a, b]$  such that  $0 < |s - t| < \delta$ .

*Proof.* Let  $\epsilon > 0$ , and suppose first that  $N = 1$ . Since  $\gamma'$  is uniformly continuous on  $[a, b]$ , there exists  $\delta > 0$  such that

$$|\gamma'(s) - \gamma'(t)| < \epsilon$$

for  $s, t \in [a, b]$  with  $|s - t| < \delta$ . Fix  $s, t \in [a, b]$  with  $0 < |s - t| < \delta$ . By the mean value theorem

$$\frac{\gamma(t) - \gamma(s)}{t - s} = \gamma'(\xi)$$

for some  $\xi$  between  $s$  and  $t$ . It follows that

$$\left| \frac{\gamma(t) - \gamma(s)}{t - s} - \gamma'(t) \right| = |\gamma'(\xi) - \gamma'(t)| < \epsilon.$$

Suppose now that  $N$  is arbitrary. By the case  $N = 1$ , there exist  $\delta_1, \dots, \delta_N > 0$  such that, for  $j = 1, \dots, N$ ,

$$\left| \frac{\gamma_j(t) - \gamma_j(s)}{t - s} - \gamma'_j(t) \right| < \frac{\epsilon}{\sqrt{N}}$$

for all  $s, t \in [a, b]$  such that  $0 < |s - t| < \delta_j$ . Since

$$\left\| \frac{\gamma(t) - \gamma(s)}{t - s} - \gamma'(t) \right\| \leq \sqrt{N} \max_{j=1, \dots, N} \left| \frac{\gamma_j(t) - \gamma_j(s)}{t - s} - \gamma'_j(t) \right|$$

for  $s, t \in [a, b]$ ,  $s \neq t$ , this yields the claim with  $\delta := \min_{j=1, \dots, N} \delta_j$ .  $\square$

**Theorem 6.1.4.** Let  $\gamma: [a, b] \rightarrow \mathbb{R}^N$  be a  $C^1$  curve. Then  $\gamma$  is rectifiable, and its length is

$$\int_a^b \|\gamma'(t)\| dt.$$



*Proof.* Given  $\epsilon > 0$ , there exists  $\delta_1 > 0$  such that

$$\left| \int_a^b \|\gamma'(t)\| dt - \sum_{j=1}^n \|\gamma'(\xi_j)\|(t_j - t_{j-1}) \right| < \frac{\epsilon}{2}$$

for each partition  $a = t_0 < t_1 < \cdots < t_n = b$  and  $\xi_j \in [t_{j-1}, t_j]$  such that  $t_j - t_{j-1} < \delta_1$  for  $j = 1, \dots, n$ . Moreover, by Lemma 6.1.3, there exists  $\delta_2 > 0$  such that

$$\left\| \frac{\gamma(t) - \gamma(s)}{t - s} - \gamma'(t) \right\| < \frac{\epsilon}{2(b-a)}$$

for  $s, t \in [a, b]$  such that  $0 < |s - t| < \delta_2$ .

Let  $\delta := \min\{\delta_1, \delta_2\}$ , and let  $a = t_0 < t_1 < \cdots < t_n = b$  such that  $\max_{j=1, \dots, n} (t_j - t_{j-1}) < \delta$ .

First, note that

$$\left| \|\gamma(t_j) - \gamma(t_{j-1})\| - \|\gamma'(t_j)\|(t_j - t_{j-1}) \right| < \frac{\epsilon}{2} \frac{t_j - t_{j-1}}{b - a}$$

for  $j = 1, \dots, n$ . It follows that

$$\begin{aligned} & \left| \sum_{j=1}^n \|\gamma(t_j) - \gamma(t_{j-1})\| - \int_a^b \|\gamma'(t)\| dt \right| \\ & \leq \left| \sum_{j=1}^n \|\gamma(t_j) - \gamma(t_{j-1})\| - \sum_{j=1}^n \|\gamma'(t_j)\|(t_j - t_{j-1}) \right| \\ & \quad + \left| \sum_{j=1}^n \|\gamma'(t_j)\|(t_j - t_{j-1}) - \int_a^b \|\gamma'(t)\| dt \right| \\ & < \sum_{j=1}^n \underbrace{\left| \|\gamma(t_j) - \gamma(t_{j-1})\| - \|\gamma'(t_j)\|(t_j - t_{j-1}) \right|}_{< \frac{\epsilon}{2} \frac{t_j - t_{j-1}}{b - a}} + \frac{\epsilon}{2} < \epsilon. \end{aligned}$$

Now let  $a = s_0 < s_1 < \cdots < s_m = b$  be any partition, and choose a partition  $a = t_0 < t_1 < \cdots < t_n = b$  such that  $\max_{j=1, \dots, n} (t_j - t_{j-1}) < \delta$  and  $\{s_0, \dots, s_m\} \subset \{t_0, \dots, t_n\}$ .

By the foregoing,

$$\sum_{j=1}^m \|\gamma(s_j) - \gamma(s_{j-1})\| \leq \sum_{j=1}^n \|\gamma(t_j) - \gamma(t_{j-1})\| < \int_a^b \|\gamma'(t)\| dt + \epsilon$$

and, since  $\epsilon > 0$  is arbitrary,

$$\sum_{j=1}^m \|\gamma(s_j) - \gamma(s_{j-1})\| \leq \int_a^b \|\gamma'(t)\| dt.$$

Hence,  $\int_a^b \|\gamma'(t)\| dt$  is an upper bound of the set (6.1), so that  $\gamma$  is rectifiable. Since, for any  $\epsilon > 0$ , we can find  $a = t_0 < t_1 < \dots < t_n = b$  with

$$\left| \sum_{j=1}^n \|\gamma(t_j) - \gamma(t_{j-1})\| - \int_a^b \|\gamma'(t)\| dt \right| < \epsilon,$$

it follows that  $\int_a^b \|\gamma'(t)\| dt$  is actually the supremum of (6.1).  $\square$

*Examples.*

1. A circle of radius  $r$  is described by the  $\mathcal{C}^1$  curve

$$\gamma: [0, 2\pi] \rightarrow \mathbb{R}^2, \quad t \mapsto (r \cos t, r \sin t),$$

with

$$\gamma'(t) = (-r \sin t, r \cos t),$$

so that  $\|\gamma'(t)\| = r$  for  $t \in [0, 2\pi]$ . Hence, the length of  $\gamma$  is

$$\int_0^{2\pi} r dt = 2\pi r.$$

2. A *cycloid* is the curve on which a point on the boundary of a circle travels while the circle is rolled along the  $x$ -axis:

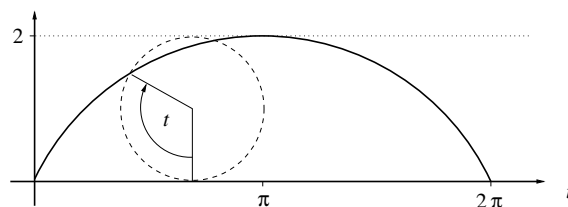

Figure 6.3: Cycloid

Mathematically, it can be described as

$$\gamma: [0, 2\pi] \rightarrow \mathbb{R}^2, \quad t \mapsto (t - \sin t, 1 - \cos t).$$

Since

$$\gamma'(t) = (1 - \cos t, \sin t)$$

we find that

$$\begin{aligned}
 \|\gamma'(t)\|^2 &= (1 - \cos t)^2 + (\sin t)^2 \\
 &= 1 - 2 \cos t + (\cos t)^2 + (\sin t)^2 \\
 &= 2 - 2 \cos t \\
 &= 2 - 2 \cos \left( \frac{t}{2} + \frac{t}{2} \right) \\
 &= 2 - 2 \cos \left( \frac{t}{2} \right)^2 + 2 \sin \left( \frac{t}{2} \right)^2 \\
 &= 2 \left( \sin \left( \frac{t}{2} \right)^2 + \sin \left( \frac{t}{2} \right)^2 \right) \\
 &= 4 \sin \left( \frac{t}{2} \right)^2
 \end{aligned}$$

for  $t \in [0, 2\pi]$ . Therefore,  $\gamma$  has the length

$$\int_0^{2\pi} 2 \left| \sin \left( \frac{t}{2} \right) \right| dt = 4 \int_0^{\pi} \sin u du = 8.$$

3. The first example is a very natural, but not unique, way to describe a circle. Here is another parametrization:

$$\gamma: [0, \sqrt{2\pi}] \rightarrow \mathbb{R}^2, \quad t \mapsto (r \cos(t^2), r \sin(t^2)).$$

Then

$$\gamma'(t) = (-2rt \sin(t^2), 2rt \cos(t^2)),$$

so that

$$\|\gamma'(t)\| = \sqrt{4r^2 t^2 (\sin(t^2)^2 + \cos(t^2)^2)} = 2rt$$

for  $t \in [0, \sqrt{2\pi}]$ . Hence, the length is

$$\int_0^{\sqrt{2\pi}} \|\gamma'(t)\| dt = \int_0^{\sqrt{2\pi}} 2rt dt = 2r \frac{t^2}{2} \Big|_{t=0}^{t=\sqrt{2\pi}} = 2\pi r,$$

in agreement with the first example.

**Theorem 6.1.5.** *Let  $\gamma: [a, b] \rightarrow \mathbb{R}^N$  be a  $C^1$  curve, and let  $\phi: [\alpha, \beta] \rightarrow [a, b]$  be a bijective  $C^1$ -function. Then  $\gamma \circ \phi$  is a  $C^1$  curve with the same length as  $\gamma$ .*

*Proof.* First, consider the case where  $\phi$  is increasing, i.e.,  $\phi' \geq 0$ . It follows that

$$\begin{aligned}
 \int_{\alpha}^{\beta} \|(\gamma \circ \phi)'(t)\| dt &= \int_{\alpha}^{\beta} \|(\gamma' \circ \phi)(t)\phi'(t)\| dt \\
 &= \int_{\alpha}^{\beta} \|(\gamma' \circ \phi)(t)\| \phi'(t) dt \\
 &= \int_{\phi(\alpha)=a}^{\phi(\beta)=b} \|\gamma'(s)\| ds.
 \end{aligned}$$

Suppose now that  $\phi$  is decreasing, meaning that  $\phi' \leq 0$ . We obtain

$$\begin{aligned} \int_{\alpha}^{\beta} \|(\gamma \circ \phi)'(t)\| dt &= \int_{\alpha}^{\beta} \|(\gamma' \circ \phi)(t)\phi'(t)\| dt \\ &= - \int_{\alpha}^{\beta} \|(\gamma' \circ \phi)(t)\|\phi'(t) dt \\ &= - \int_{\phi(\alpha)=b}^{\phi(\beta)=a} \|\gamma'(s)\| ds \\ &= \int_a^b \|\gamma'(s)\| ds. \end{aligned}$$

This completes the proof. □

The theorem and its proof extend easily to piecewise  $\mathcal{C}^1$  curves.

Next, we turn to defining (and computing) the angle between two curves:

**Definition 6.1.6.** Let  $\gamma : [a, b] \rightarrow \mathbb{R}^N$  be a  $\mathcal{C}^1$  curve. The vector  $\gamma'(t)$  is called the *tangent vector* to  $\gamma$  at  $t$ . If  $\gamma'(t) \neq 0$ ,  $\gamma$  is called *regular* at  $t$  and *singular* at  $t$  otherwise. If  $\gamma'(t) \neq 0$  for all  $t \in [a, b]$ , we simply call  $\gamma$  *regular*.

**Definition 6.1.7.** Let  $\gamma_1 : [a_1, b_1] \rightarrow \mathbb{R}^N$  and  $\gamma_2 : [a_2, b_2] \rightarrow \mathbb{R}^N$  be two  $\mathcal{C}^1$  curves, and let  $t_1 \in [a_1, b_1]$  and  $t_2 \in [a_2, b_2]$  be such that:

- (a)  $\gamma_1$  is regular at  $t_1$ ;
- (b)  $\gamma_2$  is regular at  $t_2$ ;
- (c)  $\gamma_1(t_1) = \gamma_2(t_2)$ .

Then the *angle between*  $\gamma_1$  and  $\gamma_2$  at  $\gamma_1(t_1) = \gamma_2(t_2)$  is the unique  $\theta \in [0, \pi]$  such that

$$\cos \theta = \frac{\gamma_1'(t_1) \cdot \gamma_2'(t_2)}{\|\gamma_1'(t_1)\| \|\gamma_2'(t_2)\|}.$$

Loosely speaking, the angle between two curves is the angle between the corresponding tangent vectors:

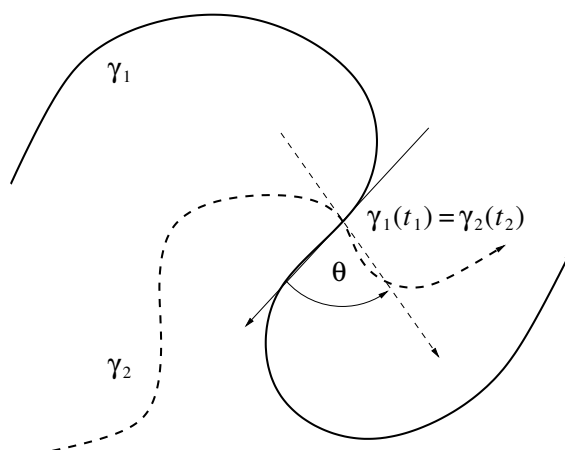

Figure 6.4: Angle between two curves

*Example.* Let

$$\gamma_1: [0, 2\pi] \rightarrow \mathbb{R}^2, \quad t \mapsto (\cos t, \sin t)$$

and

$$\gamma_2: [-1, 2] \rightarrow \mathbb{R}^2, \quad t \mapsto (t, 1 - t).$$

We wish to find the angle between  $\gamma_1$  and  $\gamma_2$  at all points where the two curves intersect. Since

$$\|\gamma_2(t)\|^2 = 2t^2 - 2t + 1 = 2(t - 1)t + 1,$$

it follows that  $\|\gamma_2(t)\| > 1$  for  $t \in [-1, 0) \cup (1, 2]$  and  $\|\gamma_2(t)\| < 1$  for all  $t \in (0, 1)$ , whereas  $\gamma_2(0) = (0, 1)$  and  $\gamma_2(1) = (1, 0)$  both have norm one and thus lie on  $\{\gamma_1\}$ . Consequently, we have

$$\{\gamma_1\} \cap \{\gamma_2\} = \left\{ (0, 1) = \gamma_1\left(\frac{\pi}{2}\right) = \gamma_2(0), (1, 0) = \gamma_1(0) = \gamma_2(1) \right\}.$$

Let  $\theta$  and  $\sigma$  denote the angle between  $\gamma_1$  and  $\gamma_2$  at  $(0, 1)$  and  $(1, 0)$ , respectively. Since

$$\gamma_1'(t) = (-\sin t, \cos t) \quad \text{and} \quad \gamma_2'(t) = (1, -1)$$

for all  $t$  in the respective parameter intervals, we conclude that

$$\cos \theta = \frac{\gamma_1'\left(\frac{\pi}{2}\right) \cdot \gamma_2'(0)}{\|\gamma_1'\left(\frac{\pi}{2}\right)\| \|\gamma_2'(0)\|} = \frac{(-1, 0) \cdot (1, -1)}{\sqrt{2}} = -\frac{1}{\sqrt{2}}$$

and

$$\cos \sigma = \frac{\gamma_1'(0) \cdot \gamma_2'(1)}{\|\gamma_1'(0)\| \|\gamma_2'(1)\|} = \frac{(0, 1) \cdot (1, -1)}{\sqrt{2}} = -\frac{1}{\sqrt{2}},$$

so that  $\theta = \sigma = \frac{3\pi}{4}$ .

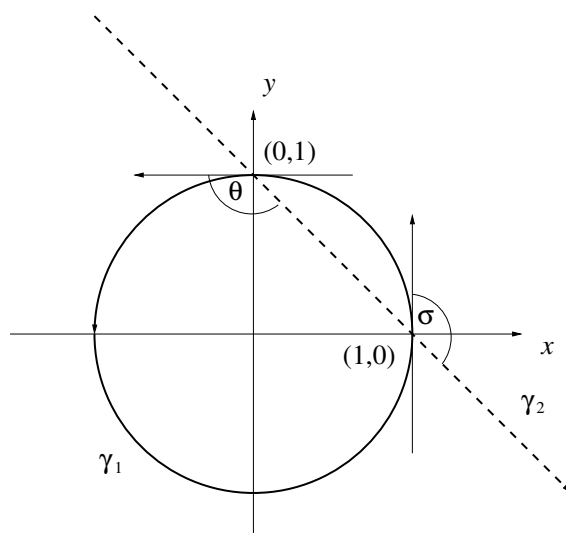

Figure 6.5: Angles between a circle and a line

How is the angle between two curves affected if we choose a different parametrization? To answer this question, we introduce another definition:

**Definition 6.1.8.** A bijective map  $\phi: [a, b] \rightarrow [\alpha, \beta]$  is called a  $\mathcal{C}^1$ -parameter transformation if both  $\phi$  and  $\phi^{-1}$  are continuously differentiable. If  $\phi$  is increasing, we call it *orientation preserving*; if  $\phi$  is decreasing, we call it *orientation reversing*.

**Definition 6.1.9.** Two curves  $\gamma_1: [a_1, b_1] \rightarrow \mathbb{R}^N$  and  $\gamma_2: [a_2, b_2] \rightarrow \mathbb{R}^N$  are called *equivalent* if there exists a  $\mathcal{C}^1$ -parameter transformation  $\phi: [a_1, b_1] \rightarrow [a_2, b_2]$  such that  $\gamma_2 = \gamma_1 \circ \phi$ .

By Theorem 6.1.5, equivalent  $\mathcal{C}^1$  curves have the same length.

**Proposition 6.1.10.** Let  $\gamma_1: [a_1, b_1] \rightarrow \mathbb{R}^N$  and  $\gamma_2: [a_2, b_2] \rightarrow \mathbb{R}^N$  be two regular  $\mathcal{C}^1$  curves, and let  $\theta$  be the angle between  $\gamma_1$  and  $\gamma_2$  at  $x \in \mathbb{R}^N$ . Moreover, let  $\phi_1: [\alpha_1, \beta_1] \rightarrow [a_1, b_1]$  and  $\phi_2: [\alpha_2, \beta_2] \rightarrow [a_2, b_2]$  be two  $\mathcal{C}^1$ -parameter transformations. Then  $\gamma_1 \circ \phi_1$  and  $\gamma_2 \circ \phi_2$  are regular  $\mathcal{C}^1$  curves, and the angle between  $\gamma_1 \circ \phi_1$  and  $\gamma_2 \circ \phi_2$  at  $x$  is:

- (i)  $\theta$  if  $\phi_1$  and  $\phi_2$  are both orientation preserving or both orientation reversing;
- (ii)  $\pi - \theta$  if one of  $\phi_1$  and  $\phi_2$  is orientation preserving and the other one is orientation reversing.

*Proof.* It is easy to see—from the chain rule—that  $\gamma_1 \circ \phi_1$  and  $\gamma_2 \circ \phi_2$  are regular.

We only prove (ii).

For  $j = 1, 2$ , let  $t_j \in [\alpha_j, \beta_j]$  be such that  $\gamma_1(\phi_1(t_1)) = \gamma_2(\phi_2(t_2)) = x$ . Suppose that  $\phi_1$  preserves orientation and that  $\phi_2$  reverses it. We obtain

$$\begin{aligned} \frac{(\gamma_1 \circ \phi_1)'(t_1) \cdot (\gamma_2 \circ \phi_2)'(t_2)}{\|(\gamma_1 \circ \phi_1)'(t_1)\| \|(\gamma_2 \circ \phi_2)'(t_2)\|} &= \frac{\gamma_1'(\phi_1(t_1))\phi_1'(t_1) \cdot \gamma_2'(\phi_2(t_2))\phi_2'(t_2)}{\|\gamma_1'(\phi_1(t_1))\phi_1'(t_1)\| \|\gamma_2'(\phi_2(t_2))\phi_2'(t_2)\|} \\ &= \frac{\phi_1'(t_1)\phi_2'(t_2) \cdot \gamma_1'(\phi_1(t_1)) \cdot \gamma_2'(\phi_2(t_2))}{-\phi_1'(t_1)\phi_2'(t_2) \|\gamma_1'(\phi_1(t_1))\| \|\gamma_2'(\phi_2(t_2))\|} \\ &= -\frac{\gamma_1'(\phi_1(t_1)) \cdot \gamma_2'(\phi_2(t_2))}{\|\gamma_1'(\phi_1(t_1))\| \|\gamma_2'(\phi_2(t_2))\|} \\ &= -\cos \theta \\ &= \cos(\pi - \theta), \end{aligned}$$

which proves the claim.  $\square$

### Exercises

1. Let  $r > 0$ , and let  $c \neq 0$ . Determine the length of the helix

$$\gamma: [a, b] \rightarrow \mathbb{R}^3, \quad t \mapsto (r \cos t, r \sin t, ct).$$

2. Let  $f: [a, b] \rightarrow \mathbb{R}$  be a  $\mathcal{C}^1$ -function. Show that the graph of  $f$  can be parametrized as a rectifiable curve with length

$$\int_a^b \sqrt{1 + f'(t)^2} dt.$$

3. (a) Let  $\gamma_1: [a, b] \rightarrow \mathbb{R}^N$  and  $\gamma_2: [b, c] \rightarrow \mathbb{R}^N$  be two curves such that  $\gamma_1(b) = \gamma_2(b)$ . The *concatenation* of  $\gamma_1$  and  $\gamma_2$  is the curve

$$\gamma_1 \oplus \gamma_2: [a, c] \rightarrow \mathbb{R}^N, \quad t \mapsto \begin{cases} \gamma_1(t), & \text{if } t \in [a, b], \\ \gamma_2(t), & \text{if } t \in [b, c]. \end{cases}$$

Show that  $\gamma_1 \oplus \gamma_2$  is rectifiable provided that  $\gamma_1$  and  $\gamma_2$  are and that

$$\text{length of } \gamma_1 \oplus \gamma_2 = \text{length of } \gamma_1 + \text{length of } \gamma_2.$$

- (b) A curve  $\gamma: [a, b] \rightarrow \mathbb{R}^N$  is called *piecewise continuously differentiable*—or short: *piecewise  $\mathcal{C}^1$* —if there exists a partition  $a = t_0 < \dots < t_n = b$  such that  $\gamma_j := \gamma|_{[t_{j-1}, t_j]}$  is continuously differentiable for  $j = 1, \dots, n$ . Show that  $\gamma$  is rectifiable and that

$$\text{length of } \gamma = \sum_{j=1}^n \int_{t_{j-1}}^{t_j} \|\gamma_j'(t)\| dt.$$

4. *Parametrization with respect to arclength.* Let  $\gamma: [a, b] \rightarrow \mathbb{R}^N$  be a regular  $\mathcal{C}^1$  curve with length  $L$ . Show that

$$\tau: [a, b] \rightarrow [0, L], \quad t \mapsto \int_a^t \|\gamma'(s)\| ds$$

is a  $\mathcal{C}^1$ -parameter transformation. Conclude that there exists a  $\mathcal{C}^1$  curve  $\tilde{\gamma}: [0, L] \rightarrow \mathbb{R}^N$  such that  $\gamma = \tilde{\gamma} \circ \tau$ .

5. Let

$$\gamma: \mathbb{R} \rightarrow \mathbb{R}^2, \quad t \mapsto (t^2 - 1, t^3 - t).$$

- (a) Sketch  $\gamma|_{[-2, 2]}$ .  
 (b) Determine all  $s \neq t$  such that  $\gamma(s) = \gamma(t)$ .  
 (c) Calculate the angle between  $\gamma$  and itself at all points  $\gamma(s) = \gamma(t)$  with  $s \neq t$ .
6. Show that

$$\gamma: [0, 1] \rightarrow \mathbb{R}^2, \quad t \mapsto \begin{cases} (1, t \cos(\frac{\pi}{t})), & t \in (0, 1], \\ (1, 0), & t = 0, \end{cases}$$

defines a curve that fails to be rectifiable. (*Hint:* Consider partitions  $0 < \frac{1}{2n} < \frac{1}{2n-1} < \dots < \frac{1}{3} < \frac{1}{2} < 1$ .)

7. Show that the following are equivalent for an open set  $U \subset \mathbb{R}^N$ :

- (i)  $U$  is connected;  
 (ii)  $U$  is path connected;  
 (iii) any two points in  $U$  can be joined by a polygonal path in  $U$ , i.e., for any  $x_1, x_2 \in U$ , there exist  $a < b$  and a polygonal path  $\gamma: [a, b] \rightarrow U$  such that  $\gamma(a) = x_1$  and  $\gamma(b) = x_2$ .

(*Hint:* For (i)  $\implies$  (iii), fix  $x_1 \in U$  and consider the set of those  $x \in U$  such that  $x_1$  and  $x$  can be joined by a polygonal path in  $U$ .)

## 6.2 Curve Integrals

Let  $v: \mathbb{R}^3 \rightarrow \mathbb{R}^3$  be a force field, i.e., at each point  $x \in \mathbb{R}^3$ , the force  $v(x)$  is exerted. This force field moves a particle along a curve  $\gamma: [a, b] \rightarrow \mathbb{R}^3$ . We would like to know the work done in the process.

If  $\gamma$  is just a line segment and  $v$  is constant, this is easy:

$$\text{work} = v \cdot (\gamma(b) - \gamma(a)).$$



For general  $\gamma$  and  $v$ , choose points  $\gamma(t_j)$  and  $\gamma(t_{j-1})$  on  $\gamma$  so close that  $\gamma$  is “almost” a line segment and that  $v$  is “almost” constant between those points. The work done by  $v$  to move the particle from  $\gamma(t_{j-1})$  to  $\gamma(t_j)$  is then approximately  $v(\eta_j) \cdot (\gamma(t_j) - \gamma(t_{j-1}))$ , for any  $\eta_j$  on  $\gamma$  “between”  $\gamma(t_{j-1})$  and  $\gamma(t_j)$ . For the the total amount of work, we thus obtain

$$\text{work} \approx \sum_{j=1}^n v(\eta_j) \cdot (\gamma(t_j) - \gamma(t_{j-1})).$$

The finer we choose the partition  $a = t_0 < t_1 < \cdots < t_n = b$ , the better this approximation of the work done should become.

These considerations motivate the following definition.

**Definition 6.2.1.** Let  $\gamma: [a, b] \rightarrow \mathbb{R}^N$  be a curve, and let  $f: \{\gamma\} \rightarrow \mathbb{R}^N$  be a function. Then  $f$  is said to be *integrable along*  $\gamma$ , if there is a real number  $I$  such that, for each  $\epsilon > 0$ , there exists  $\delta > 0$  such that for every partition  $a = t_0 < t_1 < \cdots < t_n = b$  with  $\max_{j=1, \dots, n} (t_j - t_{j-1}) < \delta$  and any  $\xi_j \in [t_{j-1}, t_j]$  for  $j = 1, \dots, n$ ,

$$\left| I - \sum_{j=1}^n f(\gamma(\xi_j)) \cdot (\gamma(t_j) - \gamma(t_{j-1})) \right| < \epsilon.$$

The number  $I$  is called the *(curve) integral of  $f$  along  $\gamma$*  and denoted by

$$\int_{\gamma} f \cdot dx \quad \text{or} \quad \int_{\gamma} f_1 dx_1 + \cdots + f_N dx_N.$$

**Theorem 6.2.2.** Let  $\gamma: [a, b] \rightarrow \mathbb{R}^N$  be a rectifiable curve, and let  $f: \{\gamma\} \rightarrow \mathbb{R}^N$  be continuous. Then  $\int_{\gamma} f \cdot dx$  exists.

We will not prove this theorem since our focus is on  $\mathcal{C}^1$  curves (see Theorem 6.2.4).

**Proposition 6.2.3.** The following properties of curve integrals hold:

- (i) Let  $\gamma: [a, b] \rightarrow \mathbb{R}^N$  and  $f, g: \{\gamma\} \rightarrow \mathbb{R}^N$  be such that  $\int_{\gamma} f \cdot dx$  and  $\int_{\gamma} g \cdot dx$  both exist, and let  $\alpha, \beta \in \mathbb{R}$ . Then  $\int_{\gamma} (\alpha f + \beta g) \cdot dx$  exists such that

$$\int_{\gamma} (\alpha f + \beta g) \cdot dx = \alpha \int_{\gamma} f \cdot dx + \beta \int_{\gamma} g \cdot dx.$$

- (ii) Let  $\gamma_1: [a, b] \rightarrow \mathbb{R}^N$ ,  $\gamma_2: [b, c] \rightarrow \mathbb{R}^N$  and  $f: \{\gamma_1\} \cup \{\gamma_2\} \rightarrow \mathbb{R}^N$  be such that  $\gamma_1(b) = \gamma_2(b)$  and that  $\int_{\gamma_1} f \cdot dx$  and  $\int_{\gamma_2} f \cdot dx$  both exist. Then the integral  $\int_{\gamma_1 \oplus \gamma_2} f \cdot dx$  of  $f$  along the concatenation  $\gamma_1 \oplus \gamma_2: [a, c] \rightarrow \mathbb{R}^N$  of  $\gamma_1$  and  $\gamma_2$  exists, with

$$\int_{\gamma_1 \oplus \gamma_2} f \cdot dx = \int_{\gamma_1} f \cdot dx + \int_{\gamma_2} f \cdot dx.$$

(iii) Let  $\gamma: [a, b] \rightarrow \mathbb{R}^N$  be rectifiable, and let  $f: \{\gamma\} \rightarrow \mathbb{R}^N$  be bounded such that  $\int_\gamma f \cdot dx$  exists. Then

$$\left| \int_\gamma f \cdot dx \right| \leq \sup\{\|f(\gamma(t))\| : t \in [a, b]\} \cdot \text{length of } \gamma.$$

*Proof.* (Only of (iii)).

Let  $\epsilon > 0$ , and choose a partition  $a = t_0 < t_1 < \cdots < t_n = b$  such that

$$\left| \int_\gamma f \cdot dx - \sum_{j=1}^n f(\gamma(t_j)) \cdot (\gamma(t_j) - \gamma(t_{j-1})) \right| < \epsilon.$$

It follows that

$$\begin{aligned} \left| \int_\gamma f \cdot dx \right| &< \left| \sum_{j=1}^n f(\gamma(t_j)) \cdot (\gamma(t_j) - \gamma(t_{j-1})) \right| + \epsilon \\ &< \sum_{j=1}^n \|f(\gamma(t_j))\| \|\gamma(t_j) - \gamma(t_{j-1})\| + \epsilon \\ &< \sup\{\|f(\gamma(t))\| : t \in [a, b]\} \cdot \sum_{j=1}^n \|\gamma(t_j) - \gamma(t_{j-1})\| + \epsilon \\ &< \sup\{\|f(\gamma(t))\| : t \in [a, b]\} \cdot \text{length of } \gamma + \epsilon. \end{aligned}$$

Since  $\epsilon > 0$  is arbitrary, this yields (iii).  $\square$

**Theorem 6.2.4.** Let  $\gamma: [a, b] \rightarrow \mathbb{R}^N$  be a  $C^1$  curve and  $f: \{\gamma\} \rightarrow \mathbb{R}^N$  be continuous. Then  $\int_\gamma f \cdot dx$  exists, with

$$\int_\gamma f \cdot dx = \int_a^b f(\gamma(t)) \cdot \gamma'(t) dt.$$

*Proof.* Let  $\epsilon > 0$  and choose  $\delta_1 > 0$  such that, for each partition  $a = t_0 < t_1 < \cdots < t_n = b$  with  $\max_{j=1, \dots, n} (t_j - t_{j-1}) < \delta_1$  and any  $\xi_j \in [t_{j-1}, t_j]$  for  $j = 1, \dots, n$ , we have

$$\left| \int_a^b f(\gamma(t)) \cdot \gamma'(t) dt - \sum_{j=1}^n f(\gamma(\xi_j)) \cdot \gamma'(\xi_j)(t_j - t_{j-1}) \right| < \frac{\epsilon}{2}.$$

Let  $C > 0$  be such that  $C \geq \sup\{\|f(\gamma(t))\| : t \in [a, b]\}$  and choose  $\delta_2 > 0$  such that

$$\left\| \frac{\gamma(t) - \gamma(s)}{t - s} - \gamma'(t) \right\| < \frac{\epsilon}{4C(b-a)}$$

for  $s, t \in [a, b]$  with  $0 < |s - t| < \delta_2$ . Since  $\gamma'$  is uniformly continuous, we may choose  $\delta_2$  so small that

$$\|\gamma'(t) - \gamma'(s)\| < \frac{\epsilon}{4C(b-a)}$$

for  $s, t \in [a, b]$  with  $|s - t| < \delta_2$ . Consequently, we obtain for  $s, t \in [a, b]$  with  $0 < t - s < \delta_2$  and  $\xi \in [s, t]$  that

$$\begin{aligned} \left\| \frac{\gamma(t) - \gamma(s)}{t - s} - \gamma'(\xi) \right\| &\leq \left\| \frac{\gamma(t) - \gamma(s)}{t - s} - \gamma'(t) \right\| + \|\gamma'(t) - \gamma'(\xi)\| \\ &< \frac{\epsilon}{4C(b-a)} + \frac{\epsilon}{4C(b-a)} \\ &= \frac{\epsilon}{2C(b-a)} \end{aligned} \quad (6.2)$$

Let  $\delta := \min\{\delta_1, \delta_2\}$ , and choose a partition  $a = t_0 < t_1 < \dots < t_n = b$  with  $\max_{j=1, \dots, n} (t_j - t_{j-1}) < \delta$ . From (6.2), we obtain for each  $j = 1, \dots, n$ ,

$$\|\gamma(t_j) - \gamma(t_{j-1}) - \gamma'(\xi_j)(t_j - t_{j-1})\| < \frac{\epsilon}{2C} \frac{t_j - t_{j-1}}{b - a}, \quad (6.3)$$

choosing any  $\xi_j \in [t_{j-1}, t_j]$ . Moreover, we have

$$\begin{aligned} &\left| \int_a^b f(\gamma(t)) \cdot \gamma'(t) dt - \sum_{j=1}^n f(\gamma(\xi_j)) \cdot (\gamma(t_j) - \gamma(t_{j-1})) \right| \\ &\leq \left| \int_a^b f(\gamma(t)) \cdot \gamma'(t) dt - \sum_{j=1}^n f(\gamma(\xi_j)) \cdot \gamma'(\xi_j)(t_j - t_{j-1}) \right| \\ &\quad + \left| \sum_{j=1}^n f(\gamma(\xi_j)) \cdot \gamma'(\xi_j)(t_j - t_{j-1}) - \sum_{j=1}^n f(\gamma(\xi_j)) \cdot (\gamma(t_j) - \gamma(t_{j-1})) \right| \\ &< \frac{\epsilon}{2} + \sum_{j=1}^n |f(\gamma(\xi_j)) \cdot (\gamma'(\xi_j)(t_j - t_{j-1}) - (\gamma(t_j) - \gamma(t_{j-1})))| \\ &\leq \frac{\epsilon}{2} + \sum_{j=1}^n \|f(\gamma(\xi_j))\| \|\gamma'(\xi_j)(t_j - t_{j-1}) - (\gamma(t_j) - \gamma(t_{j-1}))\| \\ &< \frac{\epsilon}{2} + \sum_{j=1}^n C \frac{\epsilon}{2C} \frac{t_j - t_{j-1}}{b - a} \quad \text{by (6.3)} \\ &= \frac{\epsilon}{2} + \frac{\epsilon}{2} \\ &= \epsilon. \end{aligned}$$

By the definition of a curve integral, this yields the claim.  $\square$

Of course, this theorem has an obvious extension to piecewise  $\mathcal{C}^1$  curves.

*Example.* Let

$$\gamma: [0, 4\pi] \rightarrow \mathbb{R}^3, \quad t \mapsto (\cos t, \sin t, t),$$

and let

$$f: \mathbb{R}^3 \rightarrow \mathbb{R}^3, \quad (x, y, z) \mapsto (1, \cos z, xy).$$

It follows that

$$\begin{aligned}
 \int_{\gamma} f \cdot d(x, y, z) &= \int_{\gamma} 1 \, dx + \cos z \, dy + xy \, dz \\
 &= \int_0^{4\pi} (1, \cos t, \cos t \sin t) \cdot (-\sin t, \cos t, 1) \, dt \\
 &= \int_0^{4\pi} (-\sin t + (\cos t)^2 + (\cos t)(\sin t)) \, dt \\
 &= \int_0^{4\pi} (\cos t)^2 \, dt \\
 &= 2\pi.
 \end{aligned}$$

We next turn to how a change of parameters affects curve integrals:

**Proposition 6.2.5.** *Let  $\gamma : [a, b] \rightarrow \mathbb{R}^N$  be a piecewise  $\mathcal{C}^1$  curve, let  $f : \{\gamma\} \rightarrow \mathbb{R}^N$  be continuous, and let  $\phi : [\alpha, \beta] \rightarrow [a, b]$  be a  $\mathcal{C}^1$ -parameter transformation. Then*

$$\int_{\gamma \circ \phi} f \cdot dx = \int_{\gamma} f \cdot dx$$

if  $\phi$  is orientation preserving, and

$$\int_{\gamma \circ \phi} f \cdot dx = - \int_{\gamma} f \cdot dx$$

if  $\phi$  is orientation reversing.

*Proof.* Without loss of generality, suppose that  $\gamma$  is a  $\mathcal{C}^1$  curve.

We only prove the assertion for orientation reversing  $\phi$ .

Simply note that

$$\begin{aligned}
 \int_{\gamma \circ \phi} f \cdot dx &= \int_{\alpha}^{\beta} f(\gamma(\phi(t))) \cdot (\gamma \circ \phi)'(t) \, dt \\
 &= \int_{\alpha}^{\beta} f(\gamma(\phi(t))) \cdot \gamma'(\phi(t)) \phi'(t) \, dt \\
 &= \int_b^a f(\gamma(s)) \cdot \gamma'(s) \, ds \\
 &= - \int_a^b f(\gamma(s)) \cdot \gamma'(s) \, ds \\
 &= - \int_{\gamma} f \cdot dx.
 \end{aligned}$$

This proves the claim. □

We introduce new terminology:

**Definition 6.2.6.** Let  $\emptyset \neq U \subset \mathbb{R}^N$  be open. We call a vector field  $f : U \rightarrow \mathbb{R}^N$  *conservative* with *potential function*  $F : U \rightarrow \mathbb{R}$  if  $F$  is partially differentiable such that  $f = \nabla F$ .

We previously encountered conservative vector fields under the name *gradient fields*.

**Theorem 6.2.7** (Fundamental Theorem for Curve Integrals). *Let  $\emptyset \neq U \subset \mathbb{R}^N$  be open, let  $f : U \rightarrow \mathbb{R}^N$  be a continuous, conservative vector field with potential function  $F : U \rightarrow \mathbb{R}$  and let  $\gamma : [a, b] \rightarrow U$  be a piecewise  $C^1$  curve. Then*

$$\int_{\gamma} f \cdot dx = F(\gamma(b)) - F(\gamma(a)).$$

*Proof.* Choose  $a = t_0 < t_1 < \dots < t_n = b$  such that  $\gamma|_{[t_{j-1}, t_j]}$  is continuously differentiable for  $j = 1, \dots, n$ . Then

$$\begin{aligned} \int_{\gamma} f \cdot dx &= \int_{\gamma} \nabla F \cdot dx \\ &= \sum_{j=1}^n \int_{t_{j-1}}^{t_j} \sum_{k=1}^N \frac{\partial F}{\partial x_k}(\gamma(t)) \gamma'_k(t) dt \\ &= \sum_{j=1}^n \int_{t_{j-1}}^{t_j} \frac{d}{dt} F(\gamma(t)) dt \\ &= \sum_{j=1}^n (F(\gamma(t_j)) - F(\gamma(t_{j-1}))) \\ &= F(\gamma(b)) - F(\gamma(a)), \end{aligned}$$

as claimed. □

*Remark.* The adjective “conservative” for gradient fields derives itself from the *Law of Conservation of Energy*. Suppose that  $N = 3$  and that  $f$  moves a particle of mass  $m$  along a curve  $\gamma : [a, b] \rightarrow \mathbb{R}^3$ . We suppose that  $\gamma$  is twice continuously differentiable. Then *Newton’s Second Law of Motion* states that

$$f(\gamma(t)) = m \gamma''(t)$$

for  $t \in [a, b]$ . Consequently, the work carried out is

$$\begin{aligned} \int_{\gamma} f \cdot dx &= \int_a^b f(\gamma(t)) \cdot \gamma'(t) dt \\ &= m \int_a^b \gamma''(t) \cdot \gamma'(t) dt \\ &= \frac{m}{2} \int_a^b \frac{d}{dt} \|\gamma'(t)\|^2 dt \\ &= \frac{m}{2} (\|\gamma'(b)\|^2 - \|\gamma'(a)\|^2). \end{aligned}$$

For  $t \in [a, b]$ , the *kinetic energy* at  $\gamma(t)$  is

$$K(\gamma(t)) = \frac{m}{2} \|\gamma'(t)\|^2,$$

so that

$$\text{work} = K(\gamma(b)) - K(\gamma(a)).$$

Suppose now that  $f$  is conservative with potential function  $F$ . Then the *potential energy* at  $(x, y, z)$  is  $P(x, y, z) = -F(x, y, z)$ , so that

$$\text{work} = \int_{\gamma} f \cdot dx = F(\gamma(b)) - F(\gamma(a)) = P(\gamma(a)) - P(\gamma(b)).$$

by Theorem 6.2.7. We obtain the Law of Conservation of Energy:

$$P(\gamma(a)) + K(\gamma(a)) = P(\gamma(b)) + K(\gamma(b)),$$

*Example.* Let

$$f: \mathbb{R}^3 \rightarrow \mathbb{R}^3, \quad (x, y, z) \mapsto (2xz, -1, x^2),$$

and let  $\gamma: [a, b] \rightarrow \mathbb{R}^3$  be any piecewise  $\mathcal{C}^1$  curve with  $\gamma(a) = (-4, 6, 1)$  and  $\gamma(b) = (3, 0, 1)$ . Since  $f$  is the gradient of

$$F: \mathbb{R}^3 \rightarrow \mathbb{R}, \quad (x, y, z) \mapsto x^2z - y,$$

Theorem 6.2.7 yields

$$\int_{\gamma} f \cdot dx = F(3, 0, 1) - F(-4, 6, 1) = 9 - 10 = -1.$$

Theorem 6.2.7 greatly simplifies the calculation of curve integrals of conservative vector fields. Not every vector field, however, is conservative, as we shall see very soon.

To make formulations easier, we define:

**Definition 6.2.8.** A curve  $\gamma: [a, b] \rightarrow \mathbb{R}^N$  is called *closed* if  $\gamma(a) = \gamma(b)$ .

**Corollary 6.2.9.** Let  $\emptyset \neq U \subset \mathbb{R}^N$  be open and let  $f: U \rightarrow \mathbb{R}^N$  be a continuous, conservative vector field. Then  $\int_{\gamma} f \cdot dx = 0$  for every closed, piecewise  $\mathcal{C}^1$  curve  $\gamma$  in  $U$ .

*Example.* Let  $P, Q: \mathbb{R}^2 \setminus \{(0, 0)\} \rightarrow \mathbb{R}$  be given by

$$P(x, y) = -\frac{y}{x^2 + y^2} \quad \text{and} \quad Q(x, y) = \frac{x}{x^2 + y^2}$$

for  $(x, y) \in \mathbb{R}^2 \setminus \{(0, 0)\}$ . Consider the counterclockwise oriented unit circle

$$\gamma: [0, 2\pi] \rightarrow \mathbb{R}^2, \quad t \mapsto (\cos t, \sin t);$$

in particular,  $\gamma$  is a closed  $\mathcal{C}^1$  curve. A direct evaluation yields

$$\begin{aligned} \int_{\gamma} P dx + Q dy &= \int_0^{2\pi} (P(\gamma(t)), Q(\gamma(t))) \cdot \gamma'(t) dt \\ &= \int_0^{2\pi} (-\sin t, \cos t) \cdot (-\sin t, \cos t) dt \\ &= \int_0^{2\pi} (\sin t)^2 + (\cos t)^2 dt \\ &= 2\pi, \end{aligned}$$

so that  $(P, Q)$  cannot be conservative.

Under certain circumstances, a converse of Corollary 6.2.9 is true:

**Theorem 6.2.10.** *Let  $\emptyset \neq U \subset \mathbb{R}^N$  be open and convex, and let  $f : U \rightarrow \mathbb{R}^N$  be continuous. Then the following are equivalent:*

- (i)  $f$  is conservative;
- (ii)  $\int_{\gamma} f \cdot dx = 0$  for each closed, piecewise  $\mathcal{C}^1$  curve  $\gamma$  in  $U$ .

*Proof.* (i)  $\implies$  (ii) is Corollary 6.2.9.

(ii)  $\implies$  (i): For any  $x, y \in U$ , define

$$[x, y] := \{x + t(y - x) : t \in [0, 1]\}.$$

Since  $U$  is convex, we have  $[x, y] \subset U$ . Clearly,  $[x, y]$  can be parametrized as a  $\mathcal{C}^1$  curve:

$$[0, 1] \rightarrow \mathbb{R}^N, \quad t \mapsto x + t(y - x).$$

Fix  $x_0 \in U$ , and define

$$F : U \rightarrow \mathbb{R}, \quad x \mapsto \int_{[x_0, x]} f \cdot du.$$

Let  $x \in U$ , and let  $\epsilon > 0$  be such that  $B_{\epsilon}(x) \subset U$ . Let  $h \neq 0$  be such that  $\|h\| < \epsilon$ .

We obtain

$$\begin{aligned} F(x+h) - F(x) &= \int_{[x_0, x+h]} f \cdot du - \int_{[x_0, x]} f \cdot du \\ &= \int_{[x_0, x+h]} f \cdot du - \int_{[x, x+h]} f \cdot du + \int_{[x, x+h]} f \cdot du - \int_{[x_0, x]} f \cdot du \\ &= \int_{[x_0, x+h]} f \cdot du + \int_{[x+h, x]} f \cdot du + \int_{[x, x_0]} f \cdot du + \int_{[x, x+h]} f \cdot du \\ &= \underbrace{\int_{[x_0, x+h] \oplus [x+h, x] \oplus [x, x_0]} f \cdot du}_{=0} + \int_{[x, x+h]} f \cdot du \\ &= \int_{[x, x+h]} f \cdot du. \end{aligned}$$

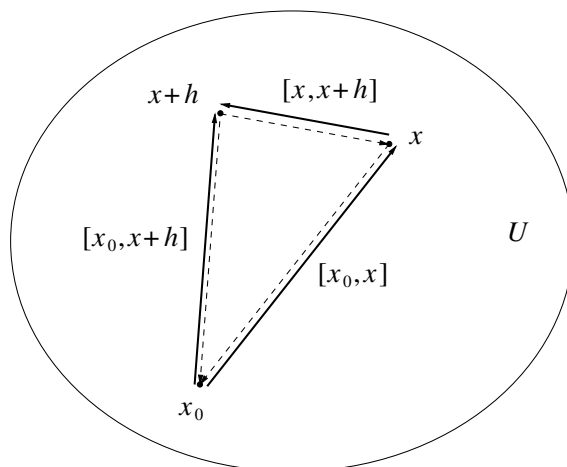

Figure 6.6: Integration curves in the proof of Theorem 6.2.10

It follows that

$$\begin{aligned} \frac{1}{\|h\|} |F(x+h) - F(x) - f(x) \cdot h| &= \frac{1}{\|h\|} \left| \int_{[x, x+h]} f \cdot du - \int_{[x, x+h]} f(x) \cdot du \right| \\ &= \frac{1}{\|h\|} \left| \int_{[x, x+h]} (f - f(x)) \cdot du \right| \leq \sup\{\|f(y) - f(x)\| : y \in [x, x+h]\}. \end{aligned} \quad (6.4)$$

Since  $f$  is continuous at  $x$ , the right hand side of (6.4) tends to zero as  $h \rightarrow 0$ .  $\square$

This theorem remains true for general open, connected sets: the given proof can be adapted to this more general situation (see Exercise 5 below).

Even though Theorem 6.2.10 is important, it is of little use to determine whether or not a given vector field is conservative. The next proposition gives a necessary condition:

**Proposition 6.2.11.** *Let  $\emptyset \neq U \subset \mathbb{R}^N$  be open, and let  $f = (f_1, \dots, f_N): U \rightarrow \mathbb{R}^N$  be a conservative  $C^1$  vector field. Then*

$$\frac{\partial f_j}{\partial x_k} = \frac{\partial f_k}{\partial x_j} \quad (6.5)$$

on  $U$  for  $j, k = 1, \dots, N$ .

*Remark.* If  $N = 3$ , (6.5) amounts to  $\text{curl } f = 0$ .

*Proof.* Let  $F: U \rightarrow \mathbb{R}$  be a potential function for  $f$ . As  $f$  is a  $C^1$  vector field, it follows that  $F$  is twice continuously partially differentiable. Hence, we obtain from Clairaut's Theorem that

$$\frac{\partial f_j}{\partial x_k} = \frac{\partial^2 F}{\partial x_k \partial x_j} = \frac{\partial^2 F}{\partial x_j \partial x_k} = \frac{\partial f_k}{\partial x_j}$$

on  $U$  for  $j, k = 1, \dots, N$ .  $\square$



Alas, (6.5) need not be sufficient for a vector field to be conservative:

*Example.* Let  $P, Q: \mathbb{R}^2 \setminus \{(0, 0)\} \rightarrow \mathbb{R}$  be given by

$$P(x, y) = -\frac{y}{x^2 + y^2} \quad \text{and} \quad Q(x, y) = \frac{x}{x^2 + y^2}$$

for  $(x, y) \in \mathbb{R}^2 \setminus \{(0, 0)\}$ . Then

$$\frac{\partial P}{\partial y} = -\frac{1}{x^2 + y^2} + \frac{2y^2}{(x^2 + y^2)^2} = \frac{-x^2 - y^2 + 2y^2}{(x^2 + y^2)^2} = \frac{-x^2 + y^2}{(x^2 + y^2)^2}$$

and

$$\frac{\partial Q}{\partial x} = \frac{1}{x^2 + y^2} - \frac{2x^2}{(x^2 + y^2)^2} = \frac{x^2 + y^2 - 2x^2}{(x^2 + y^2)^2} = \frac{-x^2 + y^2}{(x^2 + y^2)^2},$$

so that the vector field  $(P, Q)$  satisfies (6.5). However, as we have previously seen,  $(P, Q)$  is *not* conservative.

Still, for sufficiently “nice” domains, a converse of Proposition 6.2.11 holds. To prove it, we require some preparations.

**Proposition 6.2.12.** *Let  $f: [a, b] \times [c, d] \rightarrow \mathbb{R}$  be continuous, and define*

$$F: [a, b] \rightarrow \mathbb{R}, \quad x \mapsto \int_c^d f(x, y) dy.$$

*Then  $F$  is continuous.*

*Proof.* Let  $x_0 \in [a, b]$ , and let  $\epsilon > 0$ . Choose  $\delta > 0$  such that

$$|f(x, y) - f(x', y')| < \frac{\epsilon}{d - c}$$

for all  $(x, y), (x', y') \in [a, b] \times [c, d]$  such that  $\|(x, y) - (x', y')\| < \delta$ . (Remember: since  $[a, b] \times [c, d]$  is compact,  $f$  is uniformly continuous.) For  $x \in [a, b]$  such that  $|x - x_0| < \delta$ , we thus obtain

$$|F(x) - F(x_0)| = \left| \int_c^d f(x, y) dy - \int_c^d f(x_0, y) dy \right| \leq \int_c^d \underbrace{|f(x, y) - f(x_0, y)|}_{< \frac{\epsilon}{d-c}} dy \leq \epsilon,$$

which proves the claim. □

**Theorem 6.2.13.** *Let  $f: [a, b] \times [c, d] \rightarrow \mathbb{R}$  be continuous, and suppose further that  $\frac{\partial f}{\partial x}$  exists and is continuous on  $[a, b] \times [c, d]$ . Define*

$$F: [a, b] \rightarrow \mathbb{R}, \quad x \mapsto \int_c^d f(x, y) dy.$$

*Then  $F$  is continuously differentiable, with*

$$F'(x) = \int_c^d \frac{\partial f}{\partial x}(x, y) dy$$

*for  $x \in [a, b]$ .*

*Proof.* Let  $\epsilon > 0$ . Choose  $\delta > 0$  such that

$$\left| \frac{\partial f}{\partial x}(x, y) - \frac{\partial f}{\partial x}(x', y') \right| < \frac{\epsilon}{d-c}$$

for all  $(x, y), (x', y') \in [a, b] \times [c, d]$  with  $\|(x, y) - (x', y')\| < \delta$ . Fix  $x_0 \in [a, b]$  and  $y \in [c, d]$ , and let  $h \neq 0$  be such that  $x_0 + h \in [a, b]$  and  $|h| < \delta$ . By the Mean Value Theorem, there exists  $\xi_y$  between  $x_0$  and  $x_0 + h$  such that

$$\frac{f(x_0 + h, y) - f(x_0, y)}{h} = \frac{\partial f}{\partial x}(\xi_y, y).$$

As  $\|(x_0, y) - (\xi_y, y)\| < \delta$ , we have

$$\left| \frac{f(x_0 + h, y) - f(x_0, y)}{h} - \frac{\partial f}{\partial x}(x_0, y) \right| = \left| \frac{\partial f}{\partial x}(\xi_y, y) - \frac{\partial f}{\partial x}(x_0, y) \right| < \frac{\epsilon}{d-c}.$$

Whenever  $0 < |h| < \delta$  and  $x_0 + h \in [a, b]$ , it follows that

$$\begin{aligned} \left| \frac{F(x_0 + h) - F(x_0)}{h} - \int_c^d \frac{\partial f}{\partial x}(x_0, y) dy \right| & \\ & \leq \int_c^d \underbrace{\left| \frac{f(x_0 + h, y) - f(x_0, y)}{h} - \frac{\partial f}{\partial x}(x_0, y) \right|}_{< \frac{\epsilon}{d-c}} dy \leq \epsilon. \end{aligned}$$

We conclude that

$$\lim_{h \rightarrow 0} \frac{F(x_0 + h) - F(x_0)}{h} = \int_c^d \frac{\partial f}{\partial x}(x_0, y) dy,$$

so that  $F$  is differentiable at  $x_0$  with

$$F'(x_0) = \int_c^d \frac{\partial f}{\partial x}(x_0, y) dy.$$

As  $x_0 \in [a, b]$  is arbitrary, we obtain from Proposition 6.2.12 that  $F'$  is continuous as claimed.  $\square$

**Corollary 6.2.14.** *Let  $\emptyset \neq U \subset \mathbb{R}^N$  be open, and let  $f: U \times [a, b] \rightarrow \mathbb{R}$  be continuous such that  $\frac{\partial f}{\partial x_j}$  exists and is continuous throughout for  $j = 1, \dots, N$ . Then*

$$F: U \rightarrow \mathbb{R}, \quad (x_1, \dots, x_N) \mapsto \int_a^b f(x_1, \dots, x_N, y) dy$$

*is continuously partially differentiable such that*

$$\frac{\partial F}{\partial x_j}(x) = \int_a^b \frac{\partial f}{\partial x_j}(x, y) dy$$

*for  $x \in U$  and  $j = 1, \dots, N$ .*

This allows us to prove a converse to Proposition 6.2.11.

**Theorem 6.2.15.** *Let  $\emptyset \neq U \subset \mathbb{R}^N$  be open, and let  $f: U \rightarrow \mathbb{R}^N$  be a  $C^1$  vector field. Consider the following statements:*

- (i)  $f$  is conservative;
- (ii)  $f$  satisfies (6.5).

Then (i)  $\implies$  (ii), and (ii)  $\implies$  (i) if there exists  $x_0 \in U$  such that  $[x_0, x] \subset U$  for all  $x \in U$ .

*Remark.* Sets satisfying the condition for (ii)  $\implies$  (i) to hold are called *star shaped*: think of a star with  $x_0$  as its geometric center. Every convex set is trivially star shaped, but it is easy to come up with star shaped sets that are not convex (see Exercise 8 on pg. 46).

*Proof.* (i)  $\implies$  (ii) is Proposition 6.2.11.

Suppose that  $f$  satisfies (6.5) and that  $U$  is star shaped. Without loss of generality, suppose that  $x_0 = 0$ . Define

$$F: U \rightarrow \mathbb{R}, \quad x \mapsto \int_{[0,x]} f \cdot du,$$

so that

$$F(x) = \sum_{j=1}^N \left( \int_0^1 f_j(tx) dt \right) x_j$$

for  $x \in U$ . It follows for  $x \in U$  and  $k = 1, \dots, N$  that

$$\begin{aligned} \frac{\partial F}{\partial x_k}(x) &= \sum_{j=1}^N \left( \frac{\partial}{\partial x_k} \int_0^1 f_j(tx) dt \right) x_j + \sum_{j=1}^N \left( \int_0^1 f_j(tx) dt \right) \frac{\partial x_j}{\partial x_k} \\ &= \sum_{j=1}^N \left( \int_0^1 t \frac{\partial f_j}{\partial x_k}(tx) dt \right) x_j + \int_0^1 f_k(tx) dt \quad \text{by Corollary 6.2.14} \\ &= \int_0^1 \left( f_k(tx) + t \sum_{j=1}^N \frac{\partial f_j}{\partial x_k}(tx) x_j \right) dt. \end{aligned} \tag{6.6}$$

Also, note that

$$\begin{aligned} \frac{d}{dt} t f_k(tx) &= f_k(tx) + t \frac{d}{dt} f_k(tx) \\ &= f_k(tx) + t \sum_{j=1}^N \frac{\partial f_k}{\partial x_j}(tx) x_j \\ &= f_k(tx) + t \sum_{j=1}^N \frac{\partial f_j}{\partial x_k}(tx) x_j \quad \text{by (6.5)} \end{aligned} \tag{6.7}$$

for  $x \in U$  and  $k = 1, \dots, N$ . Note that (6.7) is just the integrand of (6.6), so that

$$\frac{\partial F}{\partial x_k}(x) = \int_0^1 \frac{d}{dt} t f_k(tx) dt = t f_k(tx) \Big|_0^1 = f_k(x)$$

for  $x \in U$  and  $k = 1, \dots, N$ . □

*Example.* Let

$$f: \mathbb{R}^3 \rightarrow \mathbb{R}^3, \quad (x, y, z) \mapsto (ye^{xy}, xe^{xy}, 1).$$

A routine calculation shows that  $\text{curl } f = 0$ , so that  $f$  is conservative. Let  $F: \mathbb{R}^3 \rightarrow \mathbb{R}$  be a potential function for  $f$ . It follows that

$$F(x, y, z) = \int 1 dz = z + G(x, y).$$

Differentiation with respect to  $x$  and  $y$  yields

$$\frac{\partial F}{\partial x}(x, y) = \frac{\partial G}{\partial x}(x, y) = ye^{xy} \quad \text{and} \quad \frac{\partial F}{\partial y}(x, y) = \frac{\partial G}{\partial y}(x, y) = xe^{xy},$$

so that

$$G(x, y) = \int xe^{xy} dy = e^{xy} + H(x).$$

Differentiating with respect to  $x$ , we obtain

$$\frac{\partial G}{\partial x}(x, y) = ye^{xy} + \frac{dH}{dx}(x),$$

so that  $\frac{dH}{dx} \equiv 0$  and  $H$  is constant. It follows that

$$F(x, y, z) = e^{xy} + z + C$$

for some constant  $C$ .

### Exercises

1. Calculate  $\int_{\gamma} f \cdot dx$ , where  $f(x, y) = (xy, ye^x)$ , and  $\gamma$  is the polygonal path connecting  $(0, 0)$ ,  $(2, 0)$ ,  $(2, 1)$ ,  $(0, 1)$ , and  $(0, 0)$  (in this order).
2. Let  $U := \{(x, y) \in \mathbb{R}^2 : x > 0\}$ , let  $f = (P, Q): U \rightarrow \mathbb{R}^2$  be given by

$$P(x, y) = \frac{\arctan y}{x} \quad \text{and} \quad Q(x, y) = \frac{\log x}{1 + y^2}$$

for  $(x, y) \in U$ , and let  $\gamma = \gamma_1 \oplus \gamma_2$ , where  $\gamma_1 = [(1, 7), (13, \pi)]$  and  $\gamma_2 = [(13, \pi), (e, 1)]$ .

Evaluate

$$\int_{\gamma} P dx + Q dy.$$

3. Let

$$f: \mathbb{R}^2 \rightarrow \mathbb{R}^2, \quad (x, y) \mapsto (y, y - x) \quad \text{and} \quad g: \mathbb{R}^2 \rightarrow \mathbb{R}^2, \quad (x, y) \mapsto (y, x - y).$$

Determine whether  $f$  or  $g$  are conservative. If so, determine a respective potential function.

4. Let  $f = (P, Q, R): \mathbb{R}^3 \rightarrow \mathbb{R}^3$  be given by

$$P(x, y, z) = e^{yz}, \quad Q(x, y, z) = xze^{yz}, \quad \text{and} \quad R(x, y, z) = xye^{yz}$$

for  $x, y, z \in \mathbb{R}$ , and let

$$\gamma: [0, 6\pi] \rightarrow \mathbb{R}^3, \quad t \mapsto (\cos t, \sin t, 666t).$$

Evaluate the curve integral

$$\int_{\gamma} P dx + Q dy + R dz.$$

5. Generalize Theorem 6.2.10 to general open and connected  $\emptyset \neq U \subset \mathbb{R}^N$ . For (ii)  $\implies$  (i), proceed as follows:

- Show that, if  $\gamma$  and  $\tilde{\gamma}$  are piecewise  $\mathcal{C}^1$  curves in  $U$  with same initial points and endpoints, then  $\int_{\gamma} f \cdot dx = \int_{\tilde{\gamma}} f \cdot dx$ .
- Fix  $x_0 \in U$ . By Exercise 6.1.7, there exists, for each  $x \in U$ , a piecewise  $\mathcal{C}^1$  curve  $\gamma_x$  in  $U$  with initial point  $x_0$  and endpoint  $x$ . Show that

$$F: U \rightarrow \mathbb{R}, \quad x \mapsto \int_{\gamma_x} f \cdot dx$$

is well defined and a potential function for  $f$ .

### 6.3 Green's Theorem

**Definition 6.3.1.** Let  $a < b$  and  $\phi_1, \phi_2: [a, b] \rightarrow \mathbb{R}$  be continuous with  $\phi_1 \leq \phi_2$ . Then

$$\{(x, y) \in \mathbb{R}^2 : x \in [a, b], \phi_1(x) \leq y \leq \phi_2(x)\}, \quad (6.8)$$

is called a *normal domain in  $\mathbb{R}^2$  with respect to the  $x$  axis* if, for  $j = 1, 2$ , there exist  $\alpha_j < \beta_j$  and strictly increasing  $\sigma_j: [\alpha_j, \beta_j] \rightarrow \mathbb{R}$  onto  $[a, b]$  such that

$$[\alpha_j, \beta_j] \rightarrow \mathbb{R}^2, \quad t \mapsto (\sigma_j(t), \phi_j(\sigma_j(t)))$$

are piecewise  $\mathcal{C}^1$  curves.

*Remark.* Of course, a set of the form (6.8) is a normal domain with respect to the  $x$  axis if  $\phi_1$  and  $\phi_2$  are piecewise  $\mathcal{C}^1$  functions.

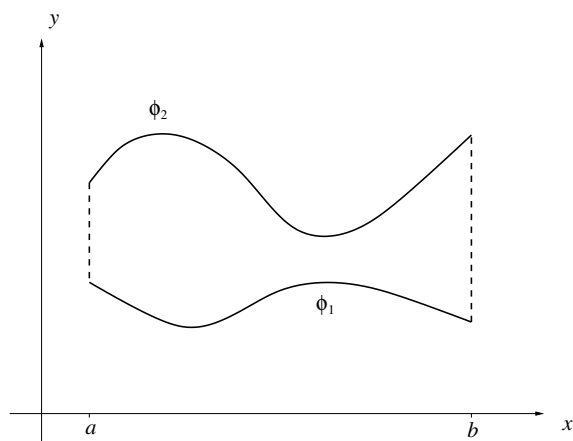

Figure 6.7: A normal domain with respect to the  $x$  axis

*Examples.*

1. A rectangle  $[a, b] \times [c, d]$  is a normal domain with respect to the  $x$  axis: define

$$\phi_1(x) = c \quad \text{and} \quad \phi_2(x) = d$$

for  $x \in [a, b]$ .

2. The closed disc of radius  $r > 0$  centered at  $(0, 0)$  in  $\mathbb{R}^2$  is of the form (6.8) with

$$\phi_1(x) = -\sqrt{r^2 - x^2} \quad \text{and} \quad \phi_2(x) = \sqrt{r^2 - x^2}$$

for  $x \in [-r, r]$ . However,  $\phi_1$  and  $\phi_2$  are *not* differentiable at  $-r$  and  $r$ . It therefore requires some more thought as to why  $B_r[(0, 0)]$  is a normal domain with respect to the  $x$  axis. Define

$$\sigma_1 = \sigma_2: \left[-\frac{\pi}{2}, \frac{\pi}{2}\right] \rightarrow \mathbb{R}, \quad t \mapsto r \sin t.$$

Then  $\sigma_1 = \sigma_2$  is strictly increasing and maps  $[-\frac{\pi}{2}, \frac{\pi}{2}]$  onto  $[-r, r]$ , and since  $\cos t$  is non-negative for  $t \in [-\frac{\pi}{2}, \frac{\pi}{2}]$ , the curves

$$\left[-\frac{\pi}{2}, \frac{\pi}{2}\right] \rightarrow \mathbb{R}^2, \quad t \mapsto (\sigma_j(t), \phi_j(\sigma_j(t))) = (r \sin t, (-1)^{j-1} r \cos t)$$

are  $\mathcal{C}^1$  curves.

Let  $K \subset \mathbb{R}^2$  be any normal domain with respect to the  $x$  axis. Then there is a natural parametrization of  $\partial K$ :

$$\partial K = \gamma_1 \oplus \gamma_2 \oplus \gamma_3 \oplus \gamma_4$$

with

$$\begin{aligned}\gamma_1(t) &:= (\sigma_1(t), \phi_1(\sigma_1(t))) && \text{for } t \in [\alpha_1, \beta_1], \\ \gamma_2(t) &:= (b, \phi_1(b) + t(\phi_2(b) - \phi_1(b))) && \text{for } t \in [0, 1], \\ \gamma_3(t) &:= (\sigma_2(\alpha_2 + \beta_2 - t), \phi_2(\sigma_2(\alpha_2 + \beta_2 - t))) && \text{for } t \in [\alpha_2, \beta_2],\end{aligned}$$

and

$$\gamma_4(t) := (a, \phi_2(a) + t(\phi_1(a) - \phi_2(a))) \quad \text{for } t \in [0, 1].$$

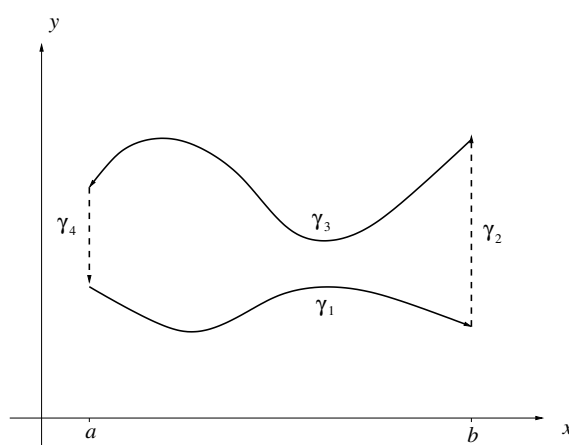

Figure 6.8: Natural parametrization of  $\partial K$

We then say that  $\partial K$  is *positively oriented*.

**Lemma 6.3.2.** *Let  $\emptyset \neq U \subset \mathbb{R}^2$  be open, let  $K \subset U$  be a normal domain with respect to the  $x$  axis, and let  $P: U \rightarrow \mathbb{R}$  be continuous such that  $\frac{\partial P}{\partial y}$  exists and is continuous. Then*

$$\int_K \frac{\partial P}{\partial y} = - \int_{\partial K} P \, dx.$$

*Proof.* To simplify the bookkeeping, we only deal with the case where  $\sigma_1$  and  $\sigma_2$  are  $\mathcal{C}^1$  functions.

First note that

$$\begin{aligned}\int_K \frac{\partial P}{\partial y} &= \int_a^b \left( \int_{\phi_1(x)}^{\phi_2(x)} \frac{\partial P}{\partial y}(x, y) \, dy \right) dx && \text{(Fubini's Theorem)} \\ &= \int_a^b (P(x, \phi_2(x)) - P(x, \phi_1(x))) \, dx && \text{(Fundamental Theorem of Calculus)}.\end{aligned}$$

As  $a = \sigma_1(\alpha_1)$  and  $b = \sigma_1(\beta_1)$ , substituting  $x = \sigma_1(t)$  yields

$$\begin{aligned} \int_a^b P(x, \phi_1(x)) dx &= \int_{\alpha_1}^{\beta_1} P(\sigma_1(t), \phi_1(\sigma_1(t)))\sigma_1'(t) dt \\ &= \int_{\alpha_1}^{\beta_1} (P(\gamma_1(t)), 0) \cdot \gamma_1'(t) dt \\ &= \int_{\gamma_1} P dx. \end{aligned}$$

Similarly, we obtain

$$\begin{aligned} \int_a^b P(x, \phi_2(x)) dx &= \int_{\alpha_2}^{\beta_2} P(\sigma_2(t), \phi_2(\sigma_2(t)))\sigma_2'(t) dt \\ &= - \int_{\beta_2}^{\alpha_2} P(\sigma_2(\alpha_2 + \beta_2 - t), \phi_2(\sigma_2(\alpha_2 + \beta_2 - t)))\sigma_2'(\alpha_2 + \beta_2 - t) dt \\ &= \int_{\alpha_2}^{\beta_2} P(\sigma_2(\alpha_2 + \beta_2 - t), \phi_2(\sigma_2(\alpha_2 + \beta_2 - t)))\sigma_2'(\alpha_2 + \beta_2 - t) dt \\ &= - \int_{\alpha_2}^{\beta_2} (P(\gamma_3(t)), 0) \cdot \gamma_3'(t) dt \\ &= - \int_{\gamma_3} P dx. \end{aligned}$$

It follows that

$$\int_K \frac{\partial P}{\partial y} = - \left( \int_{\gamma_1} P dx + \int_{\gamma_3} P dx \right).$$

Since

$$\int_{\gamma_2} P dx = \int_{\gamma_4} P dx = 0,$$

we obtain

$$\int_K \frac{\partial P}{\partial y} = - \int_{\gamma_1 \oplus \gamma_2 \oplus \gamma_3 \oplus \gamma_4} P dx = - \int_{\partial K} P dx,$$

as claimed.  $\square$

Of course, we can also define normal domains with respect to the  $y$  axis:

**Definition 6.3.3.** Let  $c < d$  and  $\psi_1, \psi_2: [c, d] \rightarrow \mathbb{R}$  be continuous with  $\psi_1 \leq \psi_2$ . Then

$$\{(x, y) \in \mathbb{R}^2 : y \in [c, d], \psi_1(y) \leq x \leq \psi_2(y)\},$$

is called a *normal domain in  $\mathbb{R}^2$  with respect to the  $y$  axis* if, for  $j = 1, 2$ , there exist  $\gamma_j < \delta_j$  and strictly increasing  $\tau_j: [\gamma_j, \delta_j] \rightarrow \mathbb{R}$  onto  $[a, b]$  such that

$$[\gamma_j, \delta_j] \rightarrow \mathbb{R}^2, \quad t \mapsto (\psi_j(\tau_j(t)), \tau_j(t))$$

are piecewise  $\mathcal{C}^1$  curves.

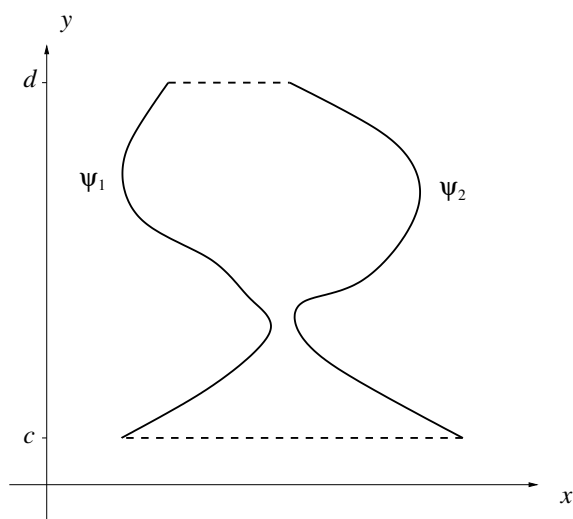

Figure 6.9: A normal domain with respect to the  $y$  axis

*Example.* Rectangles and discs are normal domains with respect to the  $y$  axis as well.

As for normal domains with respect to the  $x$  axis, there is a canonical parametrization for the boundary of every normal domain in  $\mathbb{R}^2$  with respect to the  $y$  axis. We then also call the boundary with this parametrization *positively oriented*.

With an almost identical proof as for Lemma 6.3.2, we obtain:

**Lemma 6.3.4.** *Let  $\emptyset \neq U \subset \mathbb{R}^2$  be open, let  $K \subset U$  be a normal domain with respect to the  $y$  axis, and let  $Q: U \rightarrow \mathbb{R}$  be continuous such that  $\frac{\partial Q}{\partial x}$  exists and is continuous. Then*

$$\int_K \frac{\partial Q}{\partial x} = \int_{\partial K} Q dy.$$

**Definition 6.3.5.** A set  $K \subset \mathbb{R}^2$  is called a *normal domain* if it is a normal domain with respect to both the  $x$  and the  $y$  axis.

**Theorem 6.3.6** (Green's Theorem). *Let  $\emptyset \neq U \subset \mathbb{R}^2$  be open, let  $K \subset U$  be a normal domain, and let  $P, Q \in \mathcal{C}^1(U, \mathbb{R})$ . Then*

$$\int_K \left( \frac{\partial Q}{\partial x} - \frac{\partial P}{\partial y} \right) = \int_{\partial K} P dx + Q dy.$$

*Proof.* Add the identities in Lemmas 6.3.2 and 6.3.4. □

Green's Theorem is often useful for computing curve integrals.

*Examples.*

1. Let  $K = [0, 2] \times [1, 3]$ . Then we obtain

$$\int_{\partial K} xy dx + (x^2 + y^2) dy = \int_K 2x - x = \int_0^2 \left( \int_1^3 x dy \right) dx = 4.$$

2. Let  $K = B_1[(0, 0)]$ . Then we have

$$\begin{aligned}
 & \int_{\partial K} xy^2 dx + (\arctan(\log y + 3) - x) dy \\
 &= \int_K -1 - 2xy \\
 &= - \int_K 2xy + 1 \\
 &= - \int_0^{2\pi} \left( \int_0^1 (2r^2 \cos \theta \sin \theta + 1)r dr \right) d\theta \\
 &= - \underbrace{\left( \int_0^{2\pi} \cos \theta \sin \theta d\theta \right)}_{=0} \left( 2 \int_0^1 r^3 dr \right) - 2\pi \int_0^1 r dr \\
 &= -\pi.
 \end{aligned}$$

Another nice consequence of Green's Theorem is:

**Corollary 6.3.7.** *Let  $K \subset \mathbb{R}^2$  be a normal domain. Then*

$$\mu(K) = \frac{1}{2} \int_{\partial K} x dy - y dx.$$

*Proof.* Apply Green's Theorem with  $P(x, y) = -y$  and  $Q(x, y) = x$ . □

*Remark.* Green's Theorem remains valid for much more general domains than normal ones. For instance, a triangle is normal if the edge facing the largest angle is parallel to one of the coordinate axes. We can rotate *any* triangle  $\Delta \subset \mathbb{R}^2$  suitably and obtain a triangle  $\tilde{\Delta}$  that is a normal domain:

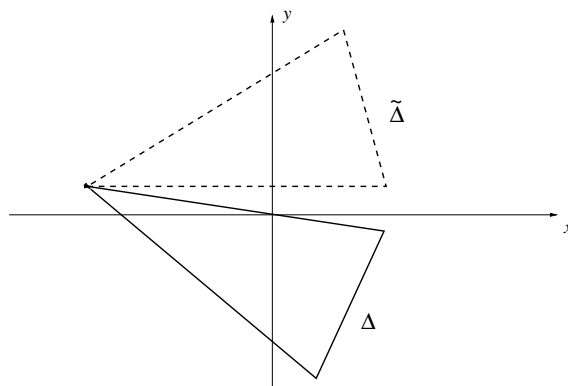

Figure 6.10: Rotating a triangle to obtain a normal domain

As  $\tilde{\Delta}$  is normal, we can apply Green's Theorem to it. A change of variables then establishes that Green's Theorem holds for  $\Delta$  as well. We can also split a rectangle, trapezoid, rhombus, or general quadrilateral into two triangles:

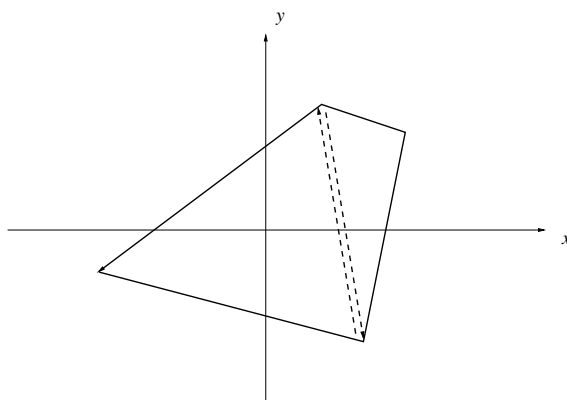

Figure 6.11: Splitting a quadrilateral into two triangles

We can then apply Green's Theorem to each of the two triangles. As the added boundary piece is traversed twice, but in opposite directions, its contributions to the boundary integrals cancel each other. Hence, Green's Theorem holds for general tetrangles. More generally, Green's Theorem applies to any polygon:

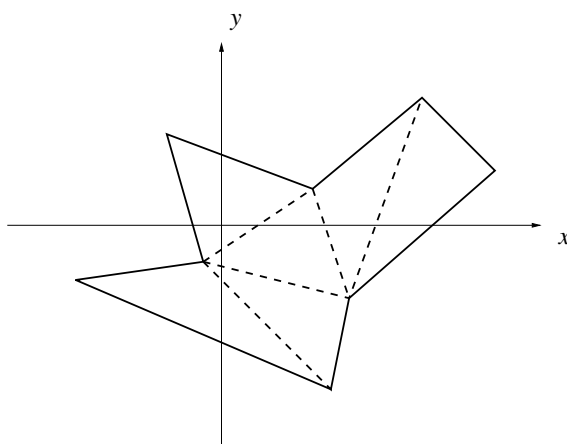

Figure 6.12: Splitting a polygon into triangles

### ***Exercises***

1. Show that

$$K := \{(x, y) \in \mathbb{R}^2 : x, y, x + y \in [0, 1]\}$$

is a normal domain (with respect to both coordinate axes) and use Green's Theorem to compute

$$\int_{\partial K} y e^x dx + x e^y dy.$$

2. Let  $K$  be the triangle with vertices  $(1, 8)$ ,  $(2, 7)$ , and  $(9, 3)$ . Evaluate the line integral

$$\int_{\partial K} \sin y \, dx + x \cos y \, dy$$

where  $\partial K$  is positively oriented.

3. Let  $a, b > 0$ . Use Green's Theorem to determine the area of the ellipse

$$E := \left\{ (x, y) \in \mathbb{R}^2 : \frac{x^2}{a^2} + \frac{y^2}{b^2} \leq 1 \right\}.$$

4. A force field  $f = (P, Q)$  with  $P, Q: \mathbb{R}^2 \rightarrow \mathbb{R}$  given by

$$P(x, y) = ye^x - y^3 + \arctan x \quad \text{and} \quad Q(x, y) = e^x + x^3 - e^{y^{2022}}$$

for  $x, y \in \mathbb{R}$  moves a particle along the curve—in counterclockwise orientation—consisting of the line segment  $\{(x, 0) : x \in [-1, 1]\}$  followed by the arc  $\{(x, y) \in \mathbb{R}^2 : x^2 + y^2 = 1, y \geq 0\}$ . Determine the work done.

## 6.4 Surfaces in $\mathbb{R}^3$

What is the area of the surface of the Earth or—more generally—what is the surface area of a sphere of radius  $r$ ?

Before we can answer this question, we of course must make precise what we mean by a surface.

**Definition 6.4.1.** Let  $U \subset \mathbb{R}^2$  be open, and let  $\emptyset \neq K \subset U$  be compact, with content. A *surface* with *parameter domain*  $K$  is the restriction of a  $C^1$ -function  $\Phi: U \rightarrow \mathbb{R}^3$  to  $K$ . The set  $\{\Phi\} := \Phi(K)$  is called the *trace* or the *surface element* of  $\Phi$ .

*Examples.*

1. Let  $r > 0$ , and let

$$\Phi: \mathbb{R}^2 \rightarrow \mathbb{R}^3, \quad (\theta, \phi) \mapsto (r \sin \theta \cos \phi, r \sin \theta \sin \phi, r \cos \theta)$$

with parameter domain

$$K := [0, \pi] \times [0, 2\pi].$$

Then  $\{\Phi\}$  is the sphere of radius  $r$  centered at  $(0, 0, 0)$ .

2. Let  $a, b \in \mathbb{R}^3$ , and let

$$\Phi: \mathbb{R}^2 \rightarrow \mathbb{R}^3, \quad (s, t) \mapsto sa + tb$$

with parameter domain  $K := [0, 1]^2$ . Then  $\{\Phi\}$  is the parallelogram spanned by  $a$  and  $b$ .

To motivate our definition of surface area below, we first discuss (and review) the surface area of a parallelogram  $P \subset \mathbb{R}^3$  spanned by  $a, b \in \mathbb{R}^3$ . In linear algebra, one defines

$$\text{area of } P := \|a \times b\|,$$

where  $a \times b \in \mathbb{R}^3$  is the cross product of  $a$  and  $b$ .

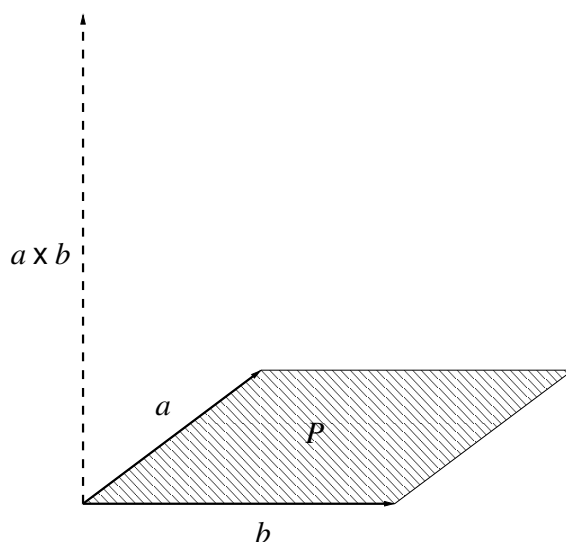

Figure 6.13: Cross product of two vectors in  $\mathbb{R}^3$

The vector  $a \times b$  is computed as follows: Let  $a = (a_1, a_2, a_3)$  and  $b = (b_1, b_2, b_3)$ , then

$$\begin{aligned} a \times b &= (a_2b_3 - a_3b_2, b_1a_3 - a_1b_3, a_1b_2 - b_1a_2) \\ &= \left( \begin{vmatrix} a_2 & a_3 \\ b_2 & b_3 \end{vmatrix}, - \begin{vmatrix} a_1 & a_3 \\ b_1 & b_3 \end{vmatrix}, \begin{vmatrix} a_1 & a_2 \\ b_1 & b_2 \end{vmatrix} \right). \end{aligned}$$

Letting  $\mathbf{i} := (1, 0, 0)$ ,  $\mathbf{j} := (0, 1, 0)$ , and  $\mathbf{k} := (0, 0, 1)$ , it is often convenient to think of  $a \times b$  as a formal determinant, i.e.,

$$a \times b = \begin{vmatrix} \mathbf{i} & \mathbf{j} & \mathbf{k} \\ a_1 & a_2 & a_3 \\ b_1 & b_2 & b_3 \end{vmatrix}$$

that we expand with respect to its first row. We need to stress, however, that this determinant is not “really” a determinant (even though it conveniently very much behaves like one).

The verification of the following is elementary:

**Proposition 6.4.2.** *The following hold for  $a, b, c \in \mathbb{R}^3$  and  $\lambda \in \mathbb{R}$ :*

- (i)  $a \times b = -b \times a$ ;
- (ii)  $a \times a = 0$ ;
- (iii)  $\lambda(a \times b) = \lambda a \times b = a \times \lambda b$ ;
- (iv)  $a \times (b + c) = a \times b + a \times c$ ;
- (v)  $(a + b) \times c = a \times c + b \times c$ .

Moreover, we have

$$c \cdot (a \times b) = \begin{vmatrix} c_1 & c_2 & c_3 \\ a_1 & a_2 & a_3 \\ b_1 & b_2 & b_3 \end{vmatrix}.$$

**Corollary 6.4.3.** For  $a, b \in \mathbb{R}^3$ ,

$$a \cdot (a \times b) = b \cdot (a \times b) = 0.$$

In geometric terms, this result means that  $a \times b$  are perpendicular to the plane spanned by  $a$  and  $b$ .

**Definition 6.4.4.** Let  $\Phi$  be a surface with parameter domain  $K$ , and let  $(s, t) \in K$ . Then the *normal vector* to  $\Phi$  in  $\Phi(s, t)$  is defined as

$$N(s, t) := \frac{\partial \Phi}{\partial s}(s, t) \times \frac{\partial \Phi}{\partial t}(s, t)$$

*Example.* Let  $a, b \in \mathbb{R}^3$ , and let

$$\Phi: \mathbb{R}^2 \rightarrow \mathbb{R}^3, \quad (s, t) \mapsto sa + tb$$

with parameter domain  $K := [0, 1]^2$ . It follows that

$$N(s, t) = a \times b,$$

so that

$$\text{surface area of } \Phi = \|a \times b\| = \int_K \|N\|.$$

Thinking of approximating a more general surface by breaking it up in small pieces reasonably close to parallelograms, we define:

**Definition 6.4.5.** Let  $\Phi(s, t)$  be a surface with parameter domain  $K$ . Then the *surface area* of  $\Phi$  is defined as

$$\int_K \|N\| = \int_K \left\| \frac{\partial \Phi}{\partial s} \times \frac{\partial \Phi}{\partial t} \right\|.$$

*Example.* Let  $r > 0$ , and consider the surface

$$\Phi: \mathbb{R}^2 \rightarrow \mathbb{R}^3, \quad (\theta, \phi) \mapsto (r \sin \theta \cos \phi, r \sin \theta \sin \phi, r \cos \theta)$$

with parameter domain

$$K := [0, \pi] \times [0, 2\pi].$$

It follows that

$$\frac{\partial \Phi}{\partial \theta}(\theta, \phi) = (r \cos \theta \cos \phi, r \cos \theta \sin \phi, -r \sin \theta)$$

and

$$\frac{\partial \Phi}{\partial \phi}(\theta, \phi) = (-r \sin \theta \sin \phi, r \sin \theta \cos \phi, 0)$$

and thus

$$\begin{aligned} N(\theta, \phi) &= \frac{\partial \Phi}{\partial \theta}(\theta, \phi) \times \frac{\partial \Phi}{\partial \phi}(\theta, \phi) \\ &= \begin{pmatrix} r \cos \theta \sin \phi & -r \sin \theta \\ r \sin \theta \cos \phi & 0 \end{pmatrix}, - \begin{pmatrix} r \cos \theta \cos \phi & -r \sin \theta \\ -r \sin \theta \sin \phi & 0 \end{pmatrix}, \\ &= r^2 (\sin \theta^2 \cos \phi, \sin \theta^2 \sin \phi, \cos \theta \sin \theta) \\ &= r \sin \theta \Phi(\theta, \phi). \end{aligned}$$

Consequently,

$$\|N(\theta, \phi)\| = \|r \sin \theta \Phi(\theta, \phi)\| = r \sin \theta \|\Phi(\theta, \phi)\| = r^2 \sin \theta$$

for  $(\theta, \phi) \in K$ . The surface area of  $\Phi$  is therefore

$$\int_K \|N\| = \int_0^{2\pi} \left( \int_0^\pi r^2 \sin \theta dt \right) ds = 2\pi r^2 \int_0^\pi \sin \theta dt = 4\pi r^2.$$

For  $r = 6378.1$  (radius of the Earth in kilometers), this yields a surface area of approximately  $5.1120 \times 10^8$  (square kilometers).

As for the length of a curve, we will now check what happens to the area of a surface if the parametrization is changed.

**Definition 6.4.6.** Let  $\emptyset \neq U, V \subset \mathbb{R}^2$  be open. A  $\mathcal{C}^1$ -map  $\psi: U \rightarrow V$  is called an *admissible parameter transformation* if:

- (a) it is injective;
- (b)  $\det J_\psi(x) \neq 0$  for all  $x \in U$  and does not change sign.

Let  $\Phi$  be a surface with parameter domain  $K$ . Let  $V \subset \mathbb{R}^2$  be open such that  $K \subset V$  and such that  $\Phi : V \rightarrow \mathbb{R}^3$  is a  $\mathcal{C}^1$ -map. Let  $\psi : U \rightarrow V$  be an admissible parameter transformation with  $\psi(U) \supset K$ . Then  $\Psi := \Phi \circ \psi$  is a surface with parameter domain  $\psi^{-1}(K)$ . We then say that  $\Psi$  is obtained from  $\Phi$  by means of the admissible parameter transformation  $\psi$ .

**Proposition 6.4.7.** *Let  $\Phi$  and  $\Psi$  be surfaces such that  $\Psi$  is obtained from  $\Phi$  by means of an admissible parameter transformation. Then  $\Phi$  and  $\Psi$  have the same surface area.*

*Proof.* Let  $\psi$  denote the admissible parameter transformation in question. The chain rule yields

$$\begin{aligned} \left( \frac{\partial \Psi}{\partial s}, \frac{\partial \Psi}{\partial t} \right) &= \left( \frac{\partial \Phi}{\partial u} \circ \psi, \frac{\partial \Phi}{\partial v} \circ \psi \right) J_\psi \\ &= \begin{bmatrix} \frac{\partial \Phi_1}{\partial u}, & \frac{\partial \Phi_1}{\partial v} \\ \frac{\partial \Phi_2}{\partial u}, & \frac{\partial \Phi_2}{\partial v} \\ \frac{\partial \Phi_3}{\partial u}, & \frac{\partial \Phi_3}{\partial v} \end{bmatrix}_{(u,v)=\psi(s,t)} \begin{bmatrix} \frac{\partial \psi_1}{\partial s}, & \frac{\partial \psi_1}{\partial t} \\ \frac{\partial \psi_2}{\partial s}, & \frac{\partial \psi_2}{\partial t} \end{bmatrix} \\ &= \begin{bmatrix} \frac{\partial \Phi_1}{\partial u} \frac{\partial \psi_1}{\partial s} + \frac{\partial \Phi_1}{\partial v} \frac{\partial \psi_2}{\partial s}, & \frac{\partial \Phi_1}{\partial u} \frac{\partial \psi_1}{\partial t} + \frac{\partial \Phi_1}{\partial v} \frac{\partial \psi_2}{\partial t} \\ \frac{\partial \Phi_2}{\partial u} \frac{\partial \psi_1}{\partial s} + \frac{\partial \Phi_2}{\partial v} \frac{\partial \psi_2}{\partial s}, & \frac{\partial \Phi_2}{\partial u} \frac{\partial \psi_1}{\partial t} + \frac{\partial \Phi_2}{\partial v} \frac{\partial \psi_2}{\partial t} \\ \frac{\partial \Phi_3}{\partial u} \frac{\partial \psi_1}{\partial s} + \frac{\partial \Phi_3}{\partial v} \frac{\partial \psi_2}{\partial s}, & \frac{\partial \Phi_3}{\partial u} \frac{\partial \psi_1}{\partial t} + \frac{\partial \Phi_3}{\partial v} \frac{\partial \psi_2}{\partial t} \end{bmatrix}_{(u,v)=\psi(s,t)}, \end{aligned}$$

Consequently, we obtain

$$\begin{aligned} &\frac{\partial \Psi}{\partial s} \times \frac{\partial \Psi}{\partial t} \\ &= \left( \det \left( \begin{bmatrix} \frac{\partial \Phi_2}{\partial u}, & \frac{\partial \Phi_2}{\partial v} \\ \frac{\partial \Phi_3}{\partial u}, & \frac{\partial \Phi_3}{\partial v} \end{bmatrix}_{\psi(s,t)} J_\psi \right), -\det \left( \begin{bmatrix} \frac{\partial \Phi_1}{\partial u}, & \frac{\partial \Phi_1}{\partial v} \\ \frac{\partial \Phi_3}{\partial u}, & \frac{\partial \Phi_3}{\partial v} \end{bmatrix}_{\psi(s,t)} J_\psi \right), \det \left( \begin{bmatrix} \frac{\partial \Phi_1}{\partial u}, & \frac{\partial \Phi_1}{\partial v} \\ \frac{\partial \Phi_2}{\partial u}, & \frac{\partial \Phi_2}{\partial v} \end{bmatrix}_{\psi(s,t)} J_\psi \right) \right) \\ &= \left( \frac{\partial \Phi}{\partial u} \circ \psi \times \frac{\partial \Phi}{\partial v} \circ \psi \right) \det J_\psi. \end{aligned}$$

A change of variables finally yields

$$\begin{aligned} \text{surface area of } \Phi &= \int_K \left\| \frac{\partial \Phi}{\partial u} \times \frac{\partial \Phi}{\partial v} \right\| \\ &= \int_{\psi^{-1}(K)} \left\| \frac{\partial \Phi}{\partial u} \circ \psi \times \frac{\partial \Phi}{\partial v} \circ \psi \right\| |\det J_\psi| \\ &= \int_{\psi^{-1}(K)} \left\| \frac{\partial \Psi}{\partial s} \times \frac{\partial \Psi}{\partial t} \right\| \\ &= \text{surface area of } \Psi. \end{aligned}$$

This was the claim.  $\square$



**Exercises**

1. Let  $\Phi$  be a surface in  $\mathbb{R}^3$  with parameter domain  $K \subset \mathbb{R}^2$ , let  $\gamma: [a, b] \rightarrow K$  be a  $\mathcal{C}^1$ -curve, and let  $\alpha := \Phi \circ \gamma$ . Show that  $\alpha'(t)$  is orthogonal to  $N(\gamma(t))$  for each  $t \in [a, b]$ .

Interpret this in geometric terms.

2. Let  $a < b$ , and let  $f \in \mathcal{C}^1([a, b], \mathbb{R})$  such that  $f \geq 0$ . Viewing the graph of  $f$  as a subset of the  $xy$ -plane in  $\mathbb{R}^3$  and rotating it about the  $x$ -axis generates a surface in  $\mathbb{R}^3$ , a so called *rotation surface*. Show that the area of this surface is

$$2\pi \int_a^b f(t) \sqrt{1 + f'(t)^2} dt.$$

What is the area of the outer hull of a cone with height  $h > 0$  whose basis is a circle of radius  $r$ ?

3. Let  $\emptyset \neq K \subset \mathbb{R}^2$  be a compact set with content, and let  $f$  be a real valued  $\mathcal{C}^1$ -function defined on an open set  $U$  containing  $K$ . Then the graph of  $f|_K$  can be considered a surface, parametrized by

$$\Phi: U \rightarrow \mathbb{R}^3, \quad (s, t) \mapsto s \mathbf{i} + t \mathbf{j} + f(s, t) \mathbf{k},$$

in  $\mathbb{R}^3$ . Show that this surface has the area

$$\int_K \sqrt{1 + \left(\frac{\partial f}{\partial x}\right)^2 + \left(\frac{\partial f}{\partial y}\right)^2}.$$

4. Let  $R > 0$ . Determine the area of the part of the sphere

$$\{(x, y, z) \in \mathbb{R}^3 : z \geq 0, x^2 + y^2 + z^2 = R^2\}$$

that lies inside the cylinder

$$\left\{ (x, y, z) \in \mathbb{R}^3 : \left(x - \frac{R}{2}\right)^2 + y^2 \leq \frac{R^2}{4} \right\}.$$

**6.5 Introduction to Differential Forms**

Let  $U \subset \mathbb{R}^2$  be an open set. Given a curve  $\gamma: \mathbb{R} \rightarrow U$ ,  $t \mapsto (x(t), y(t))$  and a  $\mathcal{C}^2$  function  $f: \mathbb{R}^2 \rightarrow \mathbb{R}$ ,  $(x, y) \mapsto f(x, y)$ , consider the composition  $h = f \circ \gamma$ . Denoting the partial derivatives of  $f$  by  $f_x$  and  $f_y$ , we know from the Chain Rule that

$$\frac{dh}{dt} = f_x \frac{dx}{dt} + f_y \frac{dy}{dt}.$$

To emphasize the independence of this result on the parameterization used to describe  $\gamma$ , we sometimes abbreviate it as

$$dh = f_x dx + f_y dy.$$

Notice that  $dh$  is linear in  $dx$  and  $dy$ .

Given a function  $\phi : U \rightarrow \mathbb{R}^2$  such that  $J_\phi$  is nonzero on  $U$ , we can change variables from  $(x, y) = \phi(u, v)$  to  $(u, v)$ . Then

$$dx = \frac{\partial \phi_1}{\partial u} du + \frac{\partial \phi_1}{\partial v} dv \quad (6.9)$$

$$dy = \frac{\partial \phi_2}{\partial u} du + \frac{\partial \phi_2}{\partial v} dv, \quad (6.10)$$

so that

$$\begin{aligned} dh &= f_x \left( \frac{\partial \phi_1}{\partial u} du + \frac{\partial \phi_1}{\partial v} dv \right) + f_y \left( \frac{\partial \phi_2}{\partial u} du + \frac{\partial \phi_2}{\partial v} dv \right) \\ &= g_u du + g_v dv, \end{aligned}$$

where  $g = f \circ \phi$ .

We thus see that the coefficients of  $dx$  and  $dy$  in the expression for  $dh$  transform linearly (in the same way that the components of a vector transform). Formally, we are thus motivated to think of linear combinations of  $dx$  and  $dy$  as objects in their own right, *even if the specified linear combination doesn't actually correspond to the partial derivatives of some  $\mathcal{C}^2$  function  $f$ .*

**Definition 6.5.1.** Let  $U \subset \mathbb{R}^N$  be an open set and let  $\mathfrak{C}_U$  be the collection of all  $\mathcal{C}^1$  curves lying in  $U$ . A *curve functional*  $f$  is a function  $f : \mathfrak{C}_U \rightarrow \mathbb{R}$ .

**Definition 6.5.2.** Let  $U \subset \mathbb{R}^N$  be an open set. A *1-form*  $\omega$  on  $U$  is a curve functional constructed from continuous functions  $A_i : U \rightarrow \mathbb{R}$  for  $i = 1, \dots, n$  such that for each  $\mathcal{C}^1$  curve  $\gamma : [a, b] \rightarrow U$ ,

$$\omega(\gamma) = \int_\gamma \omega = \sum_{i=1}^n \int_a^b A_i(\gamma(t)) \gamma'_i(t) dt.$$

We often denote  $\omega$  by

$$\omega = A_1(x_1, \dots, x_n) dx_1 + \dots + A_n(x_1, \dots, x_n) dx_n.$$

The value of  $\omega$  can only be determined once an integration path  $\gamma$  is specified. A 1-form may or may not be the exact differential of a  $\mathcal{C}^2$  function  $f$ .

*Example.*

$$\omega = 3x^2 y^2 dx + 2x^3 y dy = d(x^3 y^2)$$

is a 1-form.

*Example.* The differentials  $dx$  and  $dy$  themselves are 1-forms.

*Example.* However,

$$\omega = y^2 dx + x^2 dy \neq df$$

for any  $\mathcal{C}^2$  function  $f$  as this would require  $f_{xy} = 2y$  but  $f_{yx} = 2x$ . Nevertheless one can still evaluate  $\omega$  for any  $\mathcal{C}^1$  curve in  $\mathbb{R}^2$ .

*Example.* Not all curve functionals are 1-forms: the curve functional

$$\int_{\gamma} \sqrt{dx^2 + dy^2} = \int_a^b \sqrt{x'(t)^2 + y'(t)^2} dt$$

that returns the arclength of a curve  $\gamma : [a, b] \rightarrow \mathbb{R}^2$  is not a 1-form.

When integrating a function  $f : \mathbb{R}^2 \rightarrow \mathbb{R}$  over  $\mathbb{R}^2$ , we sometimes write  $\int_{\mathbb{R}^2} f$  as  $\int_{\mathbb{R}^2} f(x, y) dx dy$  to emphasize the integration variables. Can we think of  $dx dy$  as a product of 1 forms?

To answer this question, consider that the Change of Variables theorem requires that

$$dx dy = \det \begin{bmatrix} \frac{\partial \phi_1}{\partial u} & \frac{\partial \phi_1}{\partial v} \\ \frac{\partial \phi_2}{\partial u} & \frac{\partial \phi_2}{\partial v} \end{bmatrix} du dv.$$

However, this is inconsistent with the result of multiplying 6.9 and 6.10. So apparently we cannot think of  $dx dy$  as the product of the 1-forms  $dx$  and  $dy$ , but rather some other linear operation, which we call the *wedge product*, denoted as  $\wedge$ . Specifically, the change of variables theorem requires that

$$dx \wedge dy = \left( \frac{\partial \phi_1}{\partial u} du + \frac{\partial \phi_1}{\partial v} dv \right) \wedge \left( \frac{\partial \phi_2}{\partial u} du + \frac{\partial \phi_2}{\partial v} dv \right) = \left( \frac{\partial \phi_1}{\partial u} \frac{\partial \phi_2}{\partial v} - \frac{\partial \phi_1}{\partial v} \frac{\partial \phi_2}{\partial u} \right) du \wedge dv,$$

which is only possible in general if

$$du \wedge du = dv \wedge dv = 0$$

and

$$dv \wedge du = -du \wedge dv.$$

*Example.* Let  $U \subset \mathbb{R}^2$  be open and  $K \subset U$  be compact, with content. Let  $\phi$  be the restriction to  $K$  of a  $\mathcal{C}^1$  function from  $U$  to  $\mathbb{R}^2$ , such that  $J_{\phi} > 0$  on  $K$ . The statement

$$\mu(\phi(K)) = \int_{\phi} dx \wedge dy = \int_K \left( \frac{\partial \phi_1}{\partial u} \frac{\partial \phi_2}{\partial v} - \frac{\partial \phi_1}{\partial v} \frac{\partial \phi_2}{\partial u} \right) du \wedge dv = \int_K J_{\phi} du \wedge dv$$

emphasizes the encapsulation of the Change of Variables theorem within the wedge product.

*Definition 6.5.3.* Let  $U \subset \mathbb{R}^2$  be an open set. An *alternating 2-form*  $\omega : \mathfrak{C}_U \times \mathfrak{C}_U \rightarrow \mathbb{R}$ , is the *surface functional* constructed as the *wedge product*  $s \wedge \tau$  of two 1-forms  $s$  and  $\tau$ . The value of a 2-form  $\omega = s \wedge \tau$  on a surface  $\Phi$  is

$$\omega(\Phi) = \int_{\Phi} \omega = \int_{\Phi} s \wedge \tau.$$

## 6.6 Surface Integrals and Stokes' Theorem

Having defined surfaces in  $\mathbb{R}^3$  along with their areas, we now turn to defining—and computing—integrals of ( $\mathbb{R}$ -valued) functions and vector fields over them:

**Definition 6.6.1.** Let  $\Phi$  be a surface with parameter domain  $K$  and  $f: \{\Phi\} \rightarrow \mathbb{R}$  be continuous. Then the *surface integral* of  $f$  over  $\Phi$  is

$$\int_{\Phi} f \, d\sigma := \int_K f \circ \Phi \|N\|.$$

By definition, the surface area of  $\Phi$  is just the integral  $\int_{\Phi} 1 \, d\sigma$ . Like the surface area, the value of such an integral is invariant under admissible parameter transformations (the proof of Proposition 6.4.7 carries over verbatim).

**Definition 6.6.2.** Let  $\Phi$  be a surface with parameter domain  $K$ , and let  $P, Q, R: \{\Phi\} \rightarrow \mathbb{R}$  be continuous. Then the *surface integral* of  $f = (P, Q, R)$  over  $\Phi$  is

$$\int_{\Phi} P \, dy \wedge dz + Q \, dz \wedge dx + R \, dx \wedge dy := \int_K (f \circ \Phi) \cdot N.$$

*Example.* Let

$$\Phi: \mathbb{R}^2 \rightarrow \mathbb{R}^3, \quad (s, t) \mapsto (s \cos t, s \sin t, t).$$

and let  $K := [0, 1] \times [0, 2\pi]$ . It follows that

$$\frac{\partial \Phi}{\partial s}(s, t) := (\cos t, \sin t, 0) \quad \text{and} \quad \frac{\partial \Phi}{\partial t}(s, t) := (-s \sin t, s \cos t, 1),$$

so that

$$N(s, t) = \left( \left| \begin{array}{cc} \sin t & 0 \\ s \cos t & 1 \end{array} \right|, - \left| \begin{array}{cc} \cos t & 0 \\ -s \sin t & 1 \end{array} \right|, \left| \begin{array}{cc} \cos t & \sin t \\ -s \sin t & s \cos t \end{array} \right| \right) = (\sin t, -\cos t, s)$$

for  $(s, t) \in K$ . Then

$$\begin{aligned} \int_{\Phi} y \, dy \wedge dz - x \, dz \wedge dx &= \int_0^1 \int_0^{2\pi} (s \sin t, -s \cos t, 0) \cdot (\sin t, -\cos t, s) \, dt \, ds \\ &= \int_0^1 \int_0^{2\pi} s(\sin t)^2 + s(\cos t)^2 \, dt \, ds \\ &= 2\pi \int_0^1 s \, ds \\ &= \pi. \end{aligned}$$

**Proposition 6.6.3.** Let  $\Psi$  and  $\Phi$  be surfaces such that  $\Psi$  is obtained from  $\Phi$  by an admissible parameter transformation  $\psi$ , and let  $P, Q, R: \{\Phi\} \rightarrow \mathbb{R}$  be continuous. Then

$$\int_{\Psi} P \, dy \wedge dz + Q \, dz \wedge dx + R \, dx \wedge dy = \pm \int_{\Phi} P \, dy \wedge dz + Q \, dz \wedge dx + R \, dx \wedge dy$$

holds with “+” if  $\det J_{\psi} > 0$  and “−” if  $\det J_{\psi} < 0$ .

We skip the proof, which is very similar to that of Proposition 6.4.7.

**Definition 6.6.4.** Let  $\Phi$  be a surface with parameter domain  $K$ . The *unit normal vector*  $n(s, t)$  to  $\Phi$  in  $\Phi(s, t)$  is defined as

$$n(s, t) := \begin{cases} \frac{N(s, t)}{\|N(s, t)\|}, & \text{if } N(s, t) \neq 0, \\ 0, & \text{otherwise.} \end{cases}$$

Let  $\Phi$  be a surface (with parameter domain  $K$ ), and let  $f = (P, Q, R): \{\Phi\} \rightarrow \mathbb{R}^3$  be continuous. Then

$$\begin{aligned} \int_{\Phi} P dy \wedge dz + Q dz \wedge dx + R dx \wedge dy &= \int_K f \circ \Phi \cdot N \\ &= \int_K f \circ \Phi \cdot n \|N\| \\ &= \int_{\Phi} f \cdot n d\sigma. \end{aligned}$$

**Theorem 6.6.5** (Stokes' Theorem). *Suppose that the following hypotheses are given:*

- (a)  $\Phi$  is a  $\mathcal{C}^2$  surface for which the parameter domain  $K$  is a normal domain (with respect to both axes);
- (b) the positively oriented boundary  $\partial K$  of  $K$  is parametrized by a piecewise  $\mathcal{C}^1$  curve  $\gamma: [a, b] \rightarrow \mathbb{R}^2$ ;
- (c)  $P$ ,  $Q$ , and  $R$  are  $\mathcal{C}^1$ -functions defined on an open set containing  $\{\Phi\}$ .

Then

$$\begin{aligned} &\int_{\Phi \circ \gamma} P dx + Q dy + R dz \\ &= \int_{\Phi} \left( \frac{\partial R}{\partial y} - \frac{\partial Q}{\partial z} \right) dy \wedge dz + \left( \frac{\partial P}{\partial z} - \frac{\partial R}{\partial x} \right) dz \wedge dx + \left( \frac{\partial Q}{\partial x} - \frac{\partial P}{\partial y} \right) dx \wedge dy \\ &= \int_{\Phi} (\text{curl } f) \cdot n d\sigma, \end{aligned}$$

where  $f = (P, Q, R)$ .

*Remark.* If  $\{\Phi\}$  lies in the  $xy$ -plane, we recover (with additional hypotheses, of course) Green's Theorem.

*Proof.* Let  $\Phi(s, t) = (X(s, t), Y(s, t), Z(s, t))$  and

$$p(s, t) := P \circ \Phi(s, t) = P(X(s, t), Y(s, t), Z(s, t)).$$

We obtain

$$\begin{aligned} \int_{\Phi \circ \gamma} P dx &= \int_a^b p(\gamma(\tau)) \frac{d(X \circ \gamma)}{d\tau}(\tau) d\tau \\ &= \int_a^b p(\gamma(\tau)) \left( \frac{\partial X}{\partial s}(\gamma(\tau)) \gamma'_1(\tau) + \frac{\partial X}{\partial t}(\gamma(\tau)) \gamma'_2(\tau) \right) d\tau \\ &= \int_{\gamma} p \frac{\partial X}{\partial s} ds + p \frac{\partial X}{\partial t} dt. \end{aligned}$$

By Green's Theorem we have

$$\int_{\gamma} p \frac{\partial X}{\partial s} ds + p \frac{\partial X}{\partial t} dt = \int_K \left( \frac{\partial}{\partial s} \left( p \frac{\partial X}{\partial t} \right) - \frac{\partial}{\partial t} \left( p \frac{\partial X}{\partial s} \right) \right). \quad (6.11)$$

We now transform the integral on the right hand side of (6.11). First note that

$$\frac{\partial}{\partial s} \left( p \frac{\partial X}{\partial t} \right) - \frac{\partial}{\partial t} \left( p \frac{\partial X}{\partial s} \right) = \frac{\partial p}{\partial s} \frac{\partial X}{\partial t} + p \frac{\partial^2 X}{\partial s \partial t} - \frac{\partial p}{\partial t} \frac{\partial X}{\partial s} - p \frac{\partial^2 X}{\partial t \partial s} = \frac{\partial p}{\partial s} \frac{\partial X}{\partial t} - \frac{\partial p}{\partial t} \frac{\partial X}{\partial s}.$$

Furthermore, the Chain Rule yields

$$\frac{\partial p}{\partial s} = \frac{\partial P}{\partial x} \circ \Phi \frac{\partial X}{\partial s} + \frac{\partial P}{\partial y} \circ \Phi \frac{\partial Y}{\partial s} + \frac{\partial P}{\partial z} \circ \Phi \frac{\partial Z}{\partial s}$$

and

$$\frac{\partial p}{\partial t} = \frac{\partial P}{\partial x} \circ \Phi \frac{\partial X}{\partial t} + \frac{\partial P}{\partial y} \circ \Phi \frac{\partial Y}{\partial t} + \frac{\partial P}{\partial z} \circ \Phi \frac{\partial Z}{\partial t}.$$

Combining these results, we obtain, noting that  $\Phi$  is a  $\mathcal{C}^2$  surface,

$$\begin{aligned} &\frac{\partial p}{\partial s} \frac{\partial X}{\partial t} - \frac{\partial p}{\partial t} \frac{\partial X}{\partial s} \\ &= \frac{\partial P}{\partial y} \circ \Phi \left( \frac{\partial Y}{\partial s} \frac{\partial X}{\partial t} - \frac{\partial Y}{\partial t} \frac{\partial X}{\partial s} \right) + \frac{\partial P}{\partial z} \circ \Phi \left( \frac{\partial Z}{\partial s} \frac{\partial X}{\partial t} - \frac{\partial Z}{\partial t} \frac{\partial X}{\partial s} \right) \\ &= -\frac{\partial P}{\partial y} \circ \Phi \begin{vmatrix} \frac{\partial X}{\partial s} & \frac{\partial X}{\partial t} \\ \frac{\partial Y}{\partial s} & \frac{\partial Y}{\partial t} \end{vmatrix} + \frac{\partial P}{\partial z} \circ \Phi \begin{vmatrix} \frac{\partial Z}{\partial s} & \frac{\partial Z}{\partial t} \\ \frac{\partial X}{\partial s} & \frac{\partial X}{\partial t} \end{vmatrix} \end{aligned}$$

and therefore

$$\frac{\partial}{\partial s} \left( p \frac{\partial X}{\partial t} \right) - \frac{\partial}{\partial t} \left( p \frac{\partial X}{\partial s} \right) = -\frac{\partial P}{\partial y} \circ \Phi \begin{vmatrix} \frac{\partial X}{\partial s} & \frac{\partial X}{\partial t} \\ \frac{\partial Y}{\partial s} & \frac{\partial Y}{\partial t} \end{vmatrix} + \frac{\partial P}{\partial z} \circ \Phi \begin{vmatrix} \frac{\partial Z}{\partial s} & \frac{\partial Z}{\partial t} \\ \frac{\partial X}{\partial s} & \frac{\partial X}{\partial t} \end{vmatrix}.$$

In view of (6.11), we thus have

$$\begin{aligned} \int_{\Phi \circ \gamma} P dx &= \int_{\gamma} p \frac{\partial X}{\partial s} ds + p \frac{\partial X}{\partial t} dt \\ &= \int_K \left( -\frac{\partial P}{\partial y} \circ \Phi \begin{vmatrix} \frac{\partial X}{\partial s} & \frac{\partial X}{\partial t} \\ \frac{\partial Y}{\partial s} & \frac{\partial Y}{\partial t} \end{vmatrix} + \frac{\partial P}{\partial z} \circ \Phi \begin{vmatrix} \frac{\partial Z}{\partial s} & \frac{\partial Z}{\partial t} \\ \frac{\partial X}{\partial s} & \frac{\partial X}{\partial t} \end{vmatrix} \right) \\ &= \int_{\Phi} -\frac{\partial P}{\partial y} dx \wedge dy + \frac{\partial P}{\partial z} dz \wedge dx. \end{aligned} \quad (6.12)$$

In a similar vein, we obtain

$$\int_{\Phi \circ \gamma} Q dy = \int_{\Phi} -\frac{\partial Q}{\partial z} dy \wedge dz + \frac{\partial Q}{\partial x} dx \wedge dy \quad (6.13)$$

and

$$\int_{\Phi \circ \gamma} R dz = \int_{\Phi} -\frac{\partial R}{\partial x} dz \wedge dx + \frac{\partial R}{\partial y} dy \wedge dz. \quad (6.14)$$

Adding (6.12), (6.13), and (6.14) completes the proof.  $\square$

*Example.* Let  $\gamma$  be a counterclockwise parametrization of the circle  $\{(x, y, z) \in \mathbb{R}^3 : x^2 + z^2 = 1, y = 0\}$ , and let

$$f(x, y, z) := \left( \underbrace{x^2 z + \sqrt{x^3 + x^2 + 2}}_P, \underbrace{xy}_Q, \underbrace{xy + \sqrt{z^3 + z^2 + 2}}_R \right).$$

We want to compute

$$\int_{\gamma} P dx + Q dy + R dz.$$

Let  $\Phi$  be a surface with trace  $\{(x, y, z) \in \mathbb{R}^3 : x^2 + z^2 \leq 1, y = 0\}$ , e.g.,

$$\Phi(s, t) := (s \cos t, 0, s \sin t)$$

for  $s \in [0, 1]$  and  $t \in [0, 2\pi]$ . Then

$$\frac{\partial \Phi}{\partial s}(s, t) = (\cos t, 0, \sin t) \quad \text{and} \quad \frac{\partial \Phi}{\partial t}(s, t) = (-s \sin t, 0, s \cos t),$$

so that

$$N(s, t) = (0, -s, 0)$$

for  $(s, t) \in K := [0, 1] \times [0, 2\pi]$  and

$$n(s, t) = (0, -1, 0)$$

for  $s \in (0, 1]$  and  $t \in [0, 2\pi]$ . It follows that

$$(\operatorname{curl} f)(\Phi(s, t)) \cdot n(s, t) = - \left( \frac{\partial P}{\partial z}(\Phi(s, t)) - \underbrace{\frac{\partial R}{\partial x}(\Phi(s, t))}_{=0} \right) = -s^2(\cos t)^2$$

for  $s \in (0, 1]$  and  $t \in [0, 2\pi]$ . From Stokes' Theorem, we obtain

$$\begin{aligned} \int_{\gamma} P dx + Q dy + R dz &= \int_{\Phi} (\operatorname{curl} f) \cdot n d\sigma \\ &= \int_0^1 \int_0^{2\pi} -s^2(\cos t)^2 \|N(s, t)\| ds dt \\ &= - \left( \int_0^1 s^3 ds \right) \left( \int_0^{2\pi} (\cos t)^2 dt \right) \\ &= -\frac{\pi}{4}. \end{aligned}$$

*Remark.* Stokes' Theorem allows for a physical interpretation of the curl of a vector field.

Let  $f : \mathbb{R}^3 \rightarrow \mathbb{R}^3$ ,  $r \mapsto f(r)$  be a continuously partially differentiable three-dimensional vector field that models the velocity of a fluid, and let  $\gamma$  be a closed rectifiable curve. The *circulation of  $f$  around  $\gamma$*  given by  $\int_{\gamma} f \cdot dr$  is a measurement for the tendency of the fluid to move around  $\gamma$ . Fix any point  $r_0$  in the fluid and let  $D_{\epsilon}$  with  $\epsilon > 0$  be a closed, two-dimensional disc in the fluid, centered at  $r_0$  with radius  $\epsilon$ . As the partial derivatives of  $f$  are continuous, we obtain for  $\epsilon > 0$  sufficiently small that

$$(\operatorname{curl} f)(r) \approx (\operatorname{curl} f)(r_0)$$

for all  $r \in D_{\epsilon}$ . Stoke's Theorem then yields

$$\begin{aligned} \int_{\partial D_{\epsilon}} f \cdot dr &= \int_{D_{\epsilon}} (\operatorname{curl} f) \cdot n \, d\sigma \\ &\approx \int_{D_{\epsilon}} (\operatorname{curl} f)(r_0) \cdot n(r_0) \, d\sigma \\ &= \pi \epsilon^2 (\operatorname{curl} f)(r_0) \cdot n(r_0), \end{aligned}$$

so that

$$(\operatorname{curl} f)(r_0) \cdot n(r_0) = \lim_{\epsilon \rightarrow 0} \frac{1}{\pi \epsilon^2} \int_{\partial D_{\epsilon}} f \cdot dr.$$

Hence,  $(\operatorname{curl} f) \cdot n$  can be thought of as a measurement for the rotating effect about the axis given by  $n$ ; it is largest when  $n$  and  $\operatorname{curl} f$  are parallel.

### Exercises

1. Let  $S$  be the upper hemisphere of the unit sphere in  $\mathbb{R}^3$  (parametrized in the usual way), and let

$$f(x, y, z) := (1, xz, xy)$$

for  $(x, y, z) \in \mathbb{R}^3$ . Use Stoke's Theorem to compute

$$\int_S (\operatorname{curl} f) \cdot n \, d\sigma.$$

2. Let  $\Phi$  and  $\Psi$  be  $\mathcal{C}^2$  surfaces with parameter domain  $K$ , which is a normal region, such that  $\Phi|_{\partial K} = \Psi|_{\partial K}$ , and let  $f : V \rightarrow \mathbb{R}^3$  be continuously differentiable where  $V \subset \mathbb{R}^3$  is open and contains  $\{\Phi\} \cup \{\Psi\}$ . Show that

$$\int_{\Phi} \operatorname{curl} f \cdot n \, d\sigma = \int_{\Psi} \operatorname{curl} f \cdot n \, d\sigma.$$



## 6.7 Gauß' Theorem

Suppose that a fluid flows through a certain part of three-dimensional space. At each point  $(x, y, z)$ , suppose that the fluid has velocity  $v(x, y, z) \in \mathbb{R}^3$  (independent of time; this is called *stationary flow*) and density  $\rho(x, y, z)$ . The vector

$$f(x, y, z) := \rho(x, y, z)v(x, y, z)$$

is the *mass flux* of the flow at  $(x, y, z)$ .

Let  $S$  be a surface placed in the flow, and suppose that the normal vector  $N \neq 0$  on  $S$ . The mass passing through  $S$  in the direction of  $n$  per unit time is

$$\int_S f \cdot n \, d\sigma. \quad (6.15)$$

Let  $(x_0, y_0, z_0)$  be the lower left corner of a box with sidelengths  $\Delta x$ ,  $\Delta y$ , and  $\Delta z$ . Decompose

$$f = P \mathbf{i} + Q \mathbf{j} + R \mathbf{k}.$$

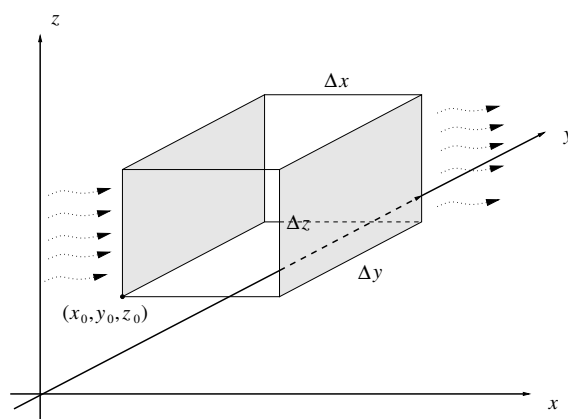

Figure 6.14: Fluid streaming through a box

Then the mass passing through the two sides of the box parallel to the  $yz$ -plane is approximately given by

$$P(x_0, y_0, z_0) \Delta y \Delta z \quad \text{and} \quad P(x_0 + \Delta x, y_0, z_0) \Delta y \Delta z.$$

The mass flowing out of the box in the direction of the positive  $x$  axis is therefore approximately

$$\begin{aligned} & (P(x_0 + \Delta x, y_0, z_0) - P(x_0, y_0, z_0)) \Delta y \Delta z \\ &= \frac{P(x_0 + \Delta x, y_0, z_0) - P(x_0, y_0, z_0)}{\Delta x} \Delta x \Delta y \Delta z \approx \frac{\partial P}{\partial x}(x_0, y_0, z_0) \Delta x \Delta y \Delta z. \end{aligned}$$

Similar considerations can be made for the positive  $y$  and  $z$  directions. We thus have

$$\text{mass flowing out of the box} \approx \left( \frac{\partial P}{\partial x} + \frac{\partial Q}{\partial y} + \frac{\partial R}{\partial z} \right) \Delta x \Delta y \Delta z = (\operatorname{div} f) \Delta x \Delta y \Delta z.$$

If  $V$  is a three-dimensional shape in the flow, we thus have

$$\text{mass flowing out of } V = \int_V \operatorname{div} f. \quad (6.16)$$

If  $V$  has the surface  $S$ , (6.15) and (6.16), yield Gauß's Theorem, namely

$$\int_S f \cdot n \, d\sigma = \int_V \operatorname{div} f$$

Of course, this is a far cry from a mathematically acceptable argument. To prove Gauß' theorem rigorously, we first have to define the domains in  $\mathbb{R}^3$  over which we shall be integrating:

**Definition 6.7.1.** Let  $U_1, U_2 \subset \mathbb{R}^2$  be open, and let  $\Phi_1 \in \mathcal{C}^1(U_1, \mathbb{R}^3)$  and  $\Phi_2 \in \mathcal{C}^1(U_2, \mathbb{R}^3)$  be surfaces with parameter domains  $K_1$  and  $K_2$ , respectively, where

$$\Phi_\nu(s, t) = X_\nu(s, t) \mathbf{i} + Y_\nu(s, t) \mathbf{j} + Z_\nu(s, t) \mathbf{k}$$

for  $\nu = 1, 2$  and  $(s, t) \in U_\nu$ . Suppose that the following hold:

(a) the functions

$$g_\nu: U_\nu \rightarrow \mathbb{R}^2, \quad (s, t) \mapsto X_\nu(s, t) \mathbf{i} + Y_\nu(s, t) \mathbf{j}$$

for  $\nu = 1, 2$  are injective and satisfy  $\det J_{g_1} < 0$  and  $\det J_{g_2} > 0$  on  $K_1$  and  $K_2$ , respectively (except on a set of content zero);

(b)  $g_1(K_1) = g_2(K_2) =: K$ ;

(c) the boundary of  $K$  is parametrized by a piecewise  $\mathcal{C}^1$  curve;

(d) there are continuous functions  $\phi_1, \phi_2: K \rightarrow \mathbb{R}$  with  $\phi_1 \leq \phi_2$  such that

$$Z_\nu(s, t) = \phi_\nu(X_\nu(s, t), Y_\nu(s, t))$$

for  $\nu = 1, 2$  and  $(s, t) \in K_\nu$ .

Then

$$V := \{(x, y, z) \in \mathbb{R}^3 : (x, y) \in K, \phi_1(x, y) \leq z \leq \phi_2(x, y)\}$$

is called a *normal domain* with respect to the  $xy$  plane. The surfaces  $\Phi_1$  and  $\Phi_2$  are called the *generating surfaces* of  $V$ ;  $S_1 := \{\Phi_1\}$  is called the *lower lid*, and  $S_2 := \{\Phi_2\}$  the *upper lid* of  $V$ .

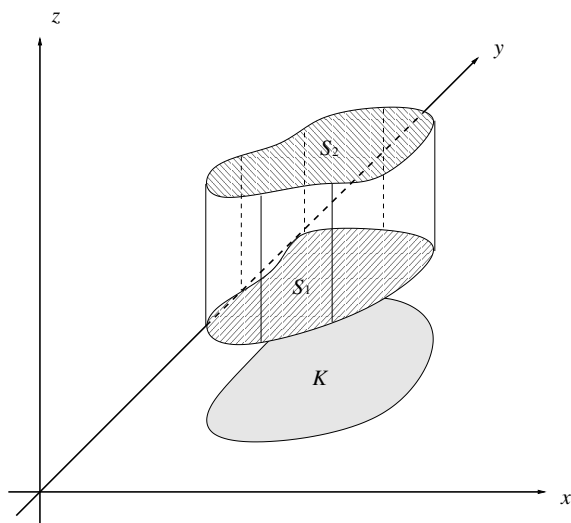
Figure 6.15: A normal domain with respect to the  $xy$  plane

*Examples.*

1. Let  $V := [a_1, a_2] \times [b_1, b_2] \times [c_1, c_2]$ . Then  $V$  is a normal domain with respect to the  $xy$  plane: Let  $K_1 := [b_1, b_2] \times [a_1, a_2]$  and  $K_2 := [a_1, a_2] \times [b_1, b_2]$ , and define

$$\Phi_1(s, t) := (t, s, c_1) \quad \text{and} \quad \Phi_2(s, t) := (s, t, c_2)$$

for  $(s, t) \in \mathbb{R}^2$ . For  $\nu = 1, 2$ , let  $\phi_\nu \equiv c_\nu$ .

2. Let  $V$  be the closed ball in  $\mathbb{R}^3$  centered at  $(0, 0, 0)$  with radius  $r > 0$ . Let  $K_1 := [\frac{\pi}{2}, \pi] \times [0, 2\pi]$  and  $K_2 := [0, \frac{\pi}{2}] \times [0, 2\pi]$ , and define

$$\Phi_1(\theta, \varphi) = \Phi_2(\theta, \varphi) := (r \sin \theta \cos \varphi, r \sin \theta \sin \varphi, r \cos \theta)$$

for  $(\theta, \varphi) \in \mathbb{R}^2$ . It follows that  $K$  is the closed disc centered at  $(0, 0)$  with radius  $r$ . Letting

$$\phi_1(x, y) = -\sqrt{r^2 - x^2 - y^2} \quad \text{and} \quad \phi_2(x, y) = \sqrt{r^2 - x^2 - y^2}$$

for  $(x, y) \in K$ , we see that  $V$  is a normal domain with respect to the  $xy$  plane.

**Lemma 6.7.2.** *Let  $U \subset \mathbb{R}^3$  be open, let  $V \subset U$  be a normal domain with respect to the  $xy$  plane, and let  $R \in \mathcal{C}^1(U, \mathbb{R})$ . Then*

$$\int_V \frac{\partial R}{\partial z} = \int_{\Phi_1} R dx \wedge dy + \int_{\Phi_2} R dx \wedge dy.$$

*Proof.* First note that

$$\int_V \frac{\partial R}{\partial z} = \int_K \left( \int_{\phi_1(x,y)}^{\phi_2(x,y)} \frac{\partial R}{\partial z} dz \right) = \int_K (R(x, y, \phi_2(x, y)) - R(x, y, \phi_1(x, y))).$$

Furthermore, we have

$$\begin{aligned} \int_K R(x, y, \phi_2(x, y)) &= \int_{g_2(K_2)} R(x, y, \phi_2(x, y)) \\ &= \int_{K_2} R(g_2(s, t), \phi_2(g_2(s, t))) \det J_{g_2}(s, t) \\ &= \int_{K_2} R(\Phi_2(s, t)) \begin{vmatrix} \frac{\partial X_2}{\partial s}(s, t) & \frac{\partial X_2}{\partial t}(s, t) \\ \frac{\partial Y_2}{\partial s}(s, t) & \frac{\partial Y_2}{\partial t}(s, t) \end{vmatrix} \\ &= \int_{K_2} (0, 0, R(\Phi_2(s, t))) \cdot N(s, t) \\ &= \int_{\Phi_2} R dx \wedge dy. \end{aligned}$$

In a similar vein, we obtain

$$\int_K R(x, y, \phi_1(x, y)) = - \int_{\Phi_1} R dx \wedge dy.$$

Thus,

$$\int_V \frac{\partial R}{\partial z} = \int_K (R(x, y, \phi_2(x, y)) - R(x, y, \phi_1(x, y))) = \int_{\Phi_1} R dx \wedge dy + \int_{\Phi_2} R dx \wedge dy.$$

□

Let  $V \subset \mathbb{R}^3$  be a normal domain with respect to the  $xy$  plane, and let  $\gamma: [a, b] \rightarrow \mathbb{R}^2$  be a piecewise  $\mathcal{C}^1$  curve that parametrizes  $\partial K$ . Let

$$K_3 := \{(s, t) \in \mathbb{R}^2 : s \in [a, b], \phi_1(\gamma(s)) \leq t \leq \phi_2(\gamma(s))\}$$

and

$$\Phi_3(s, t) := \gamma_1(s) \mathbf{i} + \gamma_2(s) \mathbf{j} + t \mathbf{k} =: X_3(s, t) \mathbf{i} + Y_3(s, t) \mathbf{j} + Z_3(s, t) \mathbf{k}$$

for  $(s, t) \in K_3$ . Then  $\Phi_3$  is a “generalized surface” whose surface element  $S_3 := \{\Phi_3\}$  is the vertical boundary of  $V$ .

Except for the points  $(s, t) \in K_3$  such that  $\gamma$  is not  $\mathcal{C}^1$  at  $s$ —which is a set of content zero—we have

$$\begin{vmatrix} \frac{\partial X_3}{\partial s}(s, t) & \frac{\partial X_3}{\partial t}(s, t) \\ \frac{\partial Y_3}{\partial s}(s, t) & \frac{\partial Y_3}{\partial t}(s, t) \end{vmatrix} = \begin{vmatrix} \gamma'_1(s) & 0 \\ \gamma'_2(s) & 0 \end{vmatrix} = 0.$$

It therefore makes sense to *define*

$$\int_{\Phi_3} R dx \wedge dy := 0.$$

Letting  $S := S_1 \cup S_2 \cup S_3 = \partial V$ , we define

$$\int_S R dx \wedge dy := \sum_{\nu=1}^3 \int_{\Phi_\nu} R dx \wedge dy.$$

In view of Lemma 6.7.2, we obtain:

**Corollary 6.7.3.** *Let  $U \subset \mathbb{R}^3$  be open, let  $V \subset U$  be a normal domain with respect to the  $xy$  plane with boundary  $S$ , and let  $R \in \mathcal{C}^1(U, \mathbb{R})$ . Then*

$$\int_V \frac{\partial R}{\partial z} = \int_S R dx \wedge dy.$$

Normal domains in  $\mathbb{R}^3$  can, of course, be defined with respect to all coordinate planes. If a subset of  $\mathbb{R}^3$  is a normal domain with respect to all coordinate planes, we simply speak of a normal domain.

**Theorem 6.7.4** (Gauß' Theorem). *Let  $U \subset \mathbb{R}^3$  be open, let  $V \subset U$  be a normal domain with boundary  $S$ , and let  $f \in \mathcal{C}^1(U, \mathbb{R}^3)$ . Then*

$$\int_S f \cdot n d\sigma = \int_V \operatorname{div} f.$$

*Proof.* Let  $f = P \mathbf{i} + Q \mathbf{j} + R \mathbf{k}$ . By Corollary 6.7.3, we have

$$\int_S R dx \wedge dy = \int_V \frac{\partial R}{\partial z}. \quad (6.17)$$

Analogous considerations yield

$$\int_S Q dz \wedge dx = \int_V \frac{\partial Q}{\partial y} \quad (6.18)$$

and

$$\int_S P dy \wedge dz = \int_V \frac{\partial P}{\partial x}. \quad (6.19)$$

Adding (6.17), (6.18), and (6.19), we obtain

$$\begin{aligned} \int_S f \cdot n d\sigma &= \int_S P dy \wedge dz + Q dz \wedge dx + R dx \wedge dy \\ &= \int_V \frac{\partial P}{\partial x} + \frac{\partial Q}{\partial y} + \frac{\partial R}{\partial z} \\ &= \int_V \operatorname{div} f. \end{aligned}$$

This proves Gauß' Theorem. □

*Examples.*

1. Let

$$V = \left\{ (x, y, z) \in \mathbb{R}^3 : x^2 + y^2 + z^2 \leq \frac{49}{\pi^e} \right\},$$

and let

$$f(x, y, z) := \left( \arctan(yz) + e^{\sin y}, \log(2 + \cos(xz)), \frac{1}{1 + x^2 y^2} \right).$$

Then Gauß' Theorem yields that

$$\int_S f \cdot n \, d\sigma = \int_V \operatorname{div} f = \int_V 0 = 0.$$

2. Let  $S$  be the unit sphere in  $\mathbb{R}^3$ . Then

$$\int_S 2xy \, dy \wedge dz - y^2 \, dz \wedge dx + z^3 \, dx \wedge dy = \int_S (2xy, -y^2, z^3) \cdot n(x, y, z) \, d\sigma$$

is difficult to compute just using the definition of a surface integral. With Gauß' Theorem, however, the task becomes relatively easy. Let

$$f(x, y, z) := (2xy, -y^2, z^3)$$

for  $(x, y, z) \in \mathbb{R}^3$ , so that

$$(\operatorname{div} f)(x, y, z) = 2y - 2y + 3z^2 = 3z^2.$$

By Gauß' theorem, we have

$$\int_S f \cdot n \, d\sigma = \int_V \operatorname{div} f = 3 \int_V z^2,$$

where  $V$  is the closed unit ball in  $\mathbb{R}^3$ . Passing to spherical coordinates and applying Fubini's Theorem, we obtain

$$\begin{aligned} \int_V z^2 &= \int_0^{2\pi} \int_0^\pi \int_0^1 (r \cos \theta)^2 r^2 \sin \theta \, dr \, d\theta \, d\varphi \\ &= 2\pi \int_0^1 r^4 \, dr \int_0^\pi (\cos \theta)^2 \sin \theta \, d\theta \\ &= \frac{2\pi}{5} \left[ -\frac{(\cos \theta)^3}{3} \right]_0^\pi \\ &= \frac{4\pi}{15}. \end{aligned}$$

It follows that

$$\int_S f \cdot n \, d\sigma = \int_V \operatorname{div} f = 3 \int_V z^2 = \frac{4\pi}{5}.$$

**Exercises**

1. Let  $S$  be the surface of the ball centered at  $(0, 0, 0)$  with radius  $r > 0$ . Compute

$$\int_S x^3 dy \wedge dz + y^3 dz \wedge dx + z^3 dx \wedge dy.$$

2. Let  $V$  be the closed unit ball in  $\mathbb{R}^3$ , and let  $S := \partial V$ . Compute

$$\int_S (2xy, -y^2, z^3) \cdot n(x, y, z) d\sigma,$$

where  $n$  is the outward pointing unit normal vector on  $S$ , and  $d\sigma$  denotes integration with respect to surface area.

3. Let  $V$  be a normal domain with boundary  $S$  such that  $N \neq 0$  on  $S$  throughout, and let  $f$  and  $g$  be  $\mathbb{R}$ -valued  $\mathcal{C}^2$ -functions on an open set containing  $V$ .

- (a) Prove *Green's First Formula*:

$$\int_V (\nabla f) \cdot (\nabla g) + \int_V f \Delta g = \int_S f D_n g d\sigma.$$

- (b) Prove *Green's Second Formula*:

$$\int_V (f \Delta g - g \Delta f) = \int_S (f D_n g - g D_n f) d\sigma.$$

(Hint for (a): Apply Gauß' Theorem to the vector field  $f \nabla g$ .)

4. Let  $\emptyset \neq U \subset \mathbb{R}^3$  be open, and suppose that  $f \in \mathcal{C}^2(U, \mathbb{R})$  is *harmonic*, i.e., satisfies  $\Delta f = 0$ . Let  $V \subset U$ ,  $S$ , and  $n$  be as in the previous problem. Show that

$$\int_S D_n f d\sigma = 0 \quad \text{and} \quad \int_S f D_n f d\sigma = \int_V \|\nabla f\|^2.$$

## Chapter 7

# Stokes' Theorem for Differential Forms

### 7.1 Alternating Multilinear Forms

**Definition 7.1.1.** Let  $r \in \mathbb{N}$ . A map  $\omega: (\mathbb{R}^N)^r \rightarrow \mathbb{R}$  is called an  $r$ -linear form if, for each  $j = 1, \dots, r$ , and all  $x_1, \dots, x_{j-1}, x_{j+1}, \dots, x_r \in \mathbb{R}^N$ , the map

$$\mathbb{R}^N \rightarrow \mathbb{R}, \quad x \mapsto \omega(x_1, \dots, x_{j-1}, x, x_{j+1}, \dots, x_r)$$

is linear.

*Example.* Let  $\omega_1, \dots, \omega_r: \mathbb{R}^N \rightarrow \mathbb{R}$  be linear. Then

$$(\mathbb{R}^N)^r \rightarrow \mathbb{R}, \quad (x_1, \dots, x_r) \mapsto \omega_1(x_1) \cdots \omega_r(x_r)$$

is an  $r$ -linear form.

**Definition 7.1.2.** Let  $r \in \mathbb{N}$ . An  $r$ -linear form  $\omega: (\mathbb{R}^N)^r \rightarrow \mathbb{R}$  is called alternating if

$$\omega(x_1, \dots, x_j, \dots, x_k, \dots, x_r) = -\omega(x_1, \dots, x_k, \dots, x_j, \dots, x_r)$$

holds for all  $x_1, \dots, x_r \in \mathbb{R}^N$  and  $1 \leq j < k \leq r$ .

We note the following:

1. For  $r = 1$ , every linear map from  $\mathbb{R}^N$  to  $\mathbb{R}$  is alternating.
2. For  $r > N$ , zero is the only alternating  $r$ -linear form: due to the linear dependence of  $r > N$  vectors  $x_1, x_2, \dots, x_r$  in  $\mathbb{R}^N$ , on relabelling we can express  $x_1 = \sum_{i=2}^r \lambda_i x_i$  for real numbers  $\lambda_i$  and hence  $\omega(x_1, \dots, x_r) = \sum_{i=2}^r \lambda_i \omega(x_i, x_2, \dots, x_r) = 0$ .
3. If we identify  $M_N(\mathbb{R})$  with  $(\mathbb{R}^N)^N$ ,  $\det$  is an alternating  $N$ -linear form.



**Definition 7.1.3.** Let  $r \in \mathbb{N}$ . Then  $\mathfrak{S}_r$  denotes the collection of all *permutations* of  $\{1, \dots, r\}$ , i.e., the set of all bijective maps from  $\{1, \dots, r\}$  onto itself.

*Remark.* The set  $\mathfrak{S}_r$  is a group under composition of maps.

**Definition 7.1.4.** A permutation  $\tau$  of  $\{1, \dots, r\}$  is called a *transposition* if it only exchanges two elements: that is, for some  $j < k$  one has  $\tau(j) = k$ ,  $\tau(k) = j$ , but  $\tau(\ell) = \ell$  for all  $\ell \in \{1, \dots, r\} \setminus \{j, k\}$ .

**Proposition 7.1.5.** Let  $r \in \mathbb{N}$  and  $\sigma \in \mathfrak{S}_r$ . Then there exist transpositions  $\tau_1, \dots, \tau_n \in \mathfrak{S}_r$  such that  $\sigma = \tau_1 \circ \dots \circ \tau_n$ .

*Proof.* We use induction on  $r$ .

The case  $r = 1$  is clear: in this case, the identity is the only element of  $\mathfrak{S}_r$ , which is a (empty) product of transpositions.

Suppose that the claim is true for all elements of  $\mathfrak{S}_r$ , and let  $\sigma \in \mathfrak{S}_{r+1}$ .

*Case 1:*  $\sigma(r+1) = r+1$ .

Then  $\sigma(\{1, \dots, r\}) \subset \{1, \dots, r\}$ , so that  $\sigma|_{\{1, \dots, r\}} \in \mathfrak{S}_r$ . By the induction hypothesis, there are  $\tau_1, \dots, \tau_n \in \mathfrak{S}_r$  such that  $\sigma|_{\{1, \dots, r\}} = \tau_1 \circ \dots \circ \tau_n$ . Define transpositions  $\tilde{\tau}_1, \dots, \tilde{\tau}_n \in \mathfrak{S}_{r+1}$  by letting  $\tilde{\tau}_j|_{\{1, \dots, r\}} = \tau_j$  and  $\tilde{\tau}_j(r+1) = r+1$  for  $j = 1, \dots, n$ . It is then clear that  $\sigma = \tilde{\tau}_1 \circ \dots \circ \tilde{\tau}_n$ .

*Case 2:*  $\sigma(r+1) \neq r+1$ .

Let  $\tau \in \mathfrak{S}_{r+1}$  be such that  $\tau(\sigma(r+1)) = r+1$ ,  $\tau(r+1) = \sigma(r+1)$ , and  $\tau(k) = k$  for  $k \in \{1, \dots, r, r+1\} \setminus \{r+1, \sigma(r+1)\}$ . It follows that  $\tau \circ \sigma \in \mathfrak{S}_{r+1}$  with  $(\tau \circ \sigma)(r+1) = r+1$ . By Case 1, this means that there are transpositions  $\tau_1, \dots, \tau_n \in \mathfrak{S}_{r+1}$  with  $\tau \circ \sigma = \tau_1 \circ \dots \circ \tau_n$ , so that  $\sigma = \tau^{-1} \circ \tau_1 \circ \dots \circ \tau_n$ .  $\square$

**Definition 7.1.6.** Let  $r \in \mathbb{N}$ . Then the *sign* of  $\sigma \in \mathfrak{S}_r$  is defined as

$$\operatorname{sgn} \sigma := \prod_{1 \leq j < k \leq r} \frac{\sigma(k) - \sigma(j)}{k - j}.$$

**Proposition 7.1.7.** Let  $r \in \mathbb{N}$ . Then:

- (i)  $\operatorname{sgn} \sigma \in \{-1, 1\}$  for all  $\sigma \in \mathfrak{S}_r$ ;
- (ii)  $\operatorname{sgn} : \mathfrak{S}_r \rightarrow \{-1, 1\}$  is a group homomorphism where  $\{-1, 1\}$  is equipped with multiplication;
- (iii)  $\omega$  is an alternating  $r$ -linear form  $\iff$

$$\omega(x_{\sigma(1)}, \dots, x_{\sigma(r)}) = \operatorname{sgn} \sigma \omega(x_1, \dots, x_r)$$

for all  $\sigma \in \mathfrak{S}_r$  and  $x_1, \dots, x_r \in \mathbb{R}^N$ .

*Proof.* For (i) note that

$$\begin{aligned}
\operatorname{sgn} \sigma &= \prod_{1 \leq j < k \leq r} \frac{\sigma(k) - \sigma(j)}{k - j} \\
&= \prod_{\substack{1 \leq j < k \leq r \\ \sigma(j) < \sigma(k)}} \frac{\sigma(k) - \sigma(j)}{k - j} \prod_{\substack{1 \leq j < k \leq r \\ \sigma(j) > \sigma(k)}} \frac{\sigma(k) - \sigma(j)}{k - j} \\
&= \prod_{\substack{1 \leq j < k \leq r \\ \sigma(j) < \sigma(k)}} (\sigma(k) - \sigma(j)) \prod_{\substack{1 \leq j < k \leq r \\ \sigma(j) < \sigma(k)}} \frac{1}{k - j} \prod_{\substack{1 \leq j < k \leq r \\ \sigma(j) > \sigma(k)}} (\sigma(k) - \sigma(j)) \prod_{\substack{1 \leq j < k \leq r \\ \sigma(j) > \sigma(k)}} \frac{1}{k - j} \\
&= \underbrace{\prod_{\substack{1 \leq j < k \leq r \\ \sigma(j) < \sigma(k)}} (k - j)}_{=1} \underbrace{\prod_{\substack{1 \leq j < k \leq r \\ \sigma(j) < \sigma(k)}} \frac{1}{k - j} \prod_{\substack{1 \leq j < k \leq r \\ \sigma(j) > \sigma(k)}} (j - k) \prod_{\substack{1 \leq j < k \leq r \\ \sigma(j) > \sigma(k)}} \frac{1}{k - j}}_{=(-1)^n} \\
&= (-1)^n,
\end{aligned}$$

where  $n$  is the number of pairs  $(j, k)$  with  $1 \leq j < k \leq N$  and  $\sigma(j) > \sigma(k)$ .

To prove (ii), let  $\sigma, \tau \in \mathfrak{S}_r$ , and note that

$$\begin{aligned}
(\operatorname{sgn})(\sigma \circ \tau) &= \prod_{1 \leq j < k \leq r} \frac{\sigma(\tau(k)) - \sigma(\tau(j))}{k - j} \\
&= \prod_{1 \leq j < k \leq r} \frac{\sigma(\tau(k)) - \sigma(\tau(j))}{\tau(k) - \tau(j)} \prod_{1 \leq j < k \leq r} \frac{\tau(k) - \tau(j)}{k - j} \\
&= \left( \prod_{1 \leq j < k \leq r} \frac{\sigma(\tau(k)) - \sigma(\tau(j))}{\tau(k) - \tau(j)} \right) \operatorname{sgn} \tau.
\end{aligned}$$

Now,

$$\begin{aligned}
\prod_{1 \leq j < k \leq r} \frac{\sigma(\tau(k)) - \sigma(\tau(j))}{\tau(k) - \tau(j)} &= \prod_{\substack{1 \leq j < k \leq r \\ \tau(j) < \tau(k)}} \frac{\sigma(\tau(k)) - \sigma(\tau(j))}{\tau(k) - \tau(j)} \prod_{\substack{1 \leq j < k \leq r \\ \tau(j) > \tau(k)}} \frac{\sigma(\tau(k)) - \sigma(\tau(j))}{\tau(k) - \tau(j)} \\
&= \prod_{\substack{1 \leq j < k \leq r \\ \tau(j) < \tau(k)}} \frac{\sigma(\tau(k)) - \sigma(\tau(j))}{\tau(k) - \tau(j)} \prod_{\substack{1 \leq j < k \leq r \\ \tau(j) > \tau(k)}} \frac{\sigma(\tau(j)) - \sigma(\tau(k))}{\tau(j) - \tau(k)} \\
&= \prod_{1 \leq j < k \leq r} \frac{\sigma(k) - \sigma(j)}{k - j} \\
&= \operatorname{sgn} \sigma,
\end{aligned}$$

so that  $\operatorname{sgn}(\sigma \circ \tau) = \operatorname{sgn} \sigma \operatorname{sgn} \tau$ , as claimed.

Finally, noting Definition 7.1.2, the property that

$$\omega(x_{\sigma(1)}, \dots, x_{\sigma(r)}) = \operatorname{sgn} \sigma \omega(x_1, \dots, x_r) \quad (7.1)$$

for every transposition  $\sigma$  and all  $x_1, \dots, x_r \in \mathbb{R}^N$  guarantees that  $\omega$  is an alternating  $r$ -linear form since  $\text{sgn } \sigma = -1$ .

Conversely, let  $\omega$  be an alternating  $r$ -linear form and  $\sigma \in \mathfrak{S}_r$ . If  $\sigma$  is a transposition, (7.1) holds by definition. If  $\sigma \in \mathfrak{S}_r$  is arbitrary, then, by Proposition 7.1.5, there exist transpositions  $\tau_1, \dots, \tau_n \in \mathfrak{S}_r$  such that  $\sigma = \tau_1 \circ \dots \circ \tau_n$ . It follows that

$$\begin{aligned} \omega(x_{\sigma(1)}, \dots, x_{\sigma(r)}) &= \omega(x_{(\tau_1 \circ \dots \circ \tau_n)(1)}, \dots, x_{(\tau_1 \circ \dots \circ \tau_n)(r)}) \\ &= \omega(x_{\tau_1((\tau_2 \circ \dots \circ \tau_n)(1))}, \dots, x_{\tau_1((\tau_2 \circ \dots \circ \tau_n)(r))}) \\ &= \text{sgn } \tau_1 \omega(x_{(\tau_2 \circ \dots \circ \tau_n)(1)}, \dots, x_{(\tau_2 \circ \dots \circ \tau_n)(r)}) \\ &\quad \vdots \\ &= \text{sgn } \tau_1 \cdots \text{sgn } \tau_n \omega(x_1, \dots, x_r) \\ &= \text{sgn } \sigma \omega(x_1, \dots, x_r) \end{aligned}$$

for all  $x_1, \dots, x_r \in \mathbb{R}^N$ , which proves (iii).  $\square$

*Example.* Let  $\omega_1, \dots, \omega_r: \mathbb{R}^N \rightarrow \mathbb{R}$  be linear. Then

$$\omega_1 \wedge \cdots \wedge \omega_r: (\mathbb{R}^N)^r \rightarrow \mathbb{R}, \quad (x_1, \dots, x_r) \mapsto \sum_{\sigma \in \mathfrak{S}_r} \text{sgn } \sigma \omega_1(x_{\sigma(1)}) \cdots \omega_r(x_{\sigma(r)})$$

is obviously an  $r$ -linear form. We claim that it is alternating. To see this, let  $\tau \in \mathfrak{S}_r$ , and note that

$$\begin{aligned} (\omega_1 \wedge \cdots \wedge \omega_r)(x_{\tau(1)}, \dots, x_{\tau(r)}) &= \sum_{\sigma \in \mathfrak{S}_r} \text{sgn } \sigma \omega_1(x_{\sigma(\tau(1))}) \cdots \omega_r(x_{\sigma(\tau(r))}) \\ &= \underbrace{(\text{sgn } \tau)^{-1}}_{=\text{sgn } \tau} \sum_{\sigma \in \mathfrak{S}_r} \text{sgn}(\sigma \circ \tau) \omega_1(x_{(\sigma \circ \tau)(1)}) \cdots \omega_r(x_{(\sigma \circ \tau)(r)}) \\ &= \text{sgn } \tau \sum_{\sigma \in \mathfrak{S}_r} \text{sgn } \sigma \omega_1(x_{\sigma(1)}) \cdots \omega_r(x_{\sigma(r)}) \\ &= \text{sgn } \tau (\omega_1 \wedge \cdots \wedge \omega_r)(x_1, \dots, x_r) \end{aligned}$$

for all  $x_1, \dots, x_r \in \mathbb{R}^N$ .

**Definition 7.1.8.** For  $r \in \mathbb{N}_0$ , let  $\Lambda^r(\mathbb{R}^N) := \mathbb{R}$  if  $r = 0$ , and

$$\Lambda^r(\mathbb{R}^N) := \{\omega: (\mathbb{R}^N)^r \rightarrow \mathbb{R} : \omega \text{ is an alternating } r\text{-linear form}\}$$

if  $r \geq 1$ .

Note that  $\Lambda^r(\mathbb{R}^N)$  is a vector space over  $\mathbb{R}$  for all  $r \in \mathbb{N}_0$ .

**Definition 7.1.9.** For  $j = 1, \dots, N$ , let

$$e_j^*: \mathbb{R}^N \rightarrow \mathbb{R}, \quad (x_1, \dots, x_N) \mapsto x_j.$$

**Theorem 7.1.10.** For  $r \in \mathbb{N}$ ,

$$\{\mathbf{e}_{j_1}^* \wedge \cdots \wedge \mathbf{e}_{j_r}^* : 1 \leq j_1 < \cdots < j_r \leq N\} \quad (7.2)$$

is a basis for  $\Lambda^r(\mathbb{R}^N)$ .

*Proof.* For  $j = 1, \dots, N$ , let  $\mathbf{e}_j$  be the  $j^{\text{th}}$  canonical unit vector of  $\mathbb{R}^N$ , i.e., the  $j^{\text{th}}$  coordinate of  $\mathbf{e}_j$  is one and all the others are zero.

Let  $\omega \in \Lambda^r(\mathbb{R}^N)$ , and let  $x_1, \dots, x_r \in \mathbb{R}^N$ . For  $k = 1, \dots, r$  and  $j = 1, \dots, N$ , let  $\lambda_{k,j} \in \mathbb{R}$  be such that  $x_k = \sum_{j=1}^N \lambda_{k,j} \mathbf{e}_j$ . It follows that

$$\begin{aligned} & \omega(x_1, \dots, x_r) \\ &= \omega\left(\sum_{j=1}^N \lambda_{1,j} \mathbf{e}_j, \dots, \sum_{j=1}^N \lambda_{r,j} \mathbf{e}_j\right) \\ &= \sum_{j_1, \dots, j_r=1}^N \lambda_{1,j_1} \cdots \lambda_{r,j_r} \omega(\mathbf{e}_{j_1}, \dots, \mathbf{e}_{j_r}) \\ &= \sum_{\substack{j_1, \dots, j_r=1 \\ j_\nu \neq j_\mu \text{ for } \nu \neq \mu}}^N \lambda_{1,j_1} \cdots \lambda_{r,j_r} \omega(\mathbf{e}_{j_1}, \dots, \mathbf{e}_{j_r}) \\ &= \sum_{1 \leq j_1 < \cdots < j_r \leq N} \sum_{\sigma \in \mathfrak{S}_r} \lambda_{1,j_{\sigma(1)}} \cdots \lambda_{r,j_{\sigma(r)}} \omega(\mathbf{e}_{j_{\sigma(1)}}, \dots, \mathbf{e}_{j_{\sigma(r)}}) \\ &= \sum_{1 \leq j_1 < \cdots < j_r \leq N} \sum_{\sigma \in \mathfrak{S}_r} \lambda_{1,j_{\sigma(1)}} \cdots \lambda_{r,j_{\sigma(r)}} \operatorname{sgn} \sigma \omega(\mathbf{e}_{j_1}, \dots, \mathbf{e}_{j_r}) \\ &= \sum_{1 \leq j_1 < \cdots < j_r \leq N} \omega(\mathbf{e}_{j_1}, \dots, \mathbf{e}_{j_r}) \sum_{\sigma \in \mathfrak{S}_r} \lambda_{1,j_{\sigma(1)}} \cdots \lambda_{r,j_{\sigma(r)}} \operatorname{sgn} \sigma (\mathbf{e}_{j_1}^* \wedge \cdots \wedge \mathbf{e}_{j_r}^*)(\mathbf{e}_{j_1}, \dots, \mathbf{e}_{j_r}) \\ &= \sum_{1 \leq j_1 < \cdots < j_r \leq N} \omega(\mathbf{e}_{j_1}, \dots, \mathbf{e}_{j_r}) \sum_{\sigma \in \mathfrak{S}_r} \lambda_{1,j_{\sigma(1)}} \cdots \lambda_{r,j_{\sigma(r)}} (\mathbf{e}_{j_1}^* \wedge \cdots \wedge \mathbf{e}_{j_r}^*)(\mathbf{e}_{j_{\sigma(1)}}, \dots, \mathbf{e}_{j_{\sigma(r)}}) \\ &= \sum_{1 \leq j_1 < \cdots < j_r \leq N} \omega(\mathbf{e}_{j_1}, \dots, \mathbf{e}_{j_r}) (\mathbf{e}_{j_1}^* \wedge \cdots \wedge \mathbf{e}_{j_r}^*)(x_1, \dots, x_r). \end{aligned}$$

Consequently, (7.2) spans  $\Lambda^r(\mathbb{R}^N)$ . It is easy to see that the elements of (7.2) are linearly independent and therefore form a basis of  $\Lambda^r(\mathbb{R}^N)$ .  $\square$

**Corollary 7.1.11.** For  $0 \leq r \leq N$ , we have  $\dim \Lambda^r(\mathbb{R}^N) = \binom{N}{r}$ .

**Corollary 7.1.12.**  $\Lambda^N(\mathbb{R}^N) = \mathbb{R}$ .

We now define the *wedge product* of alternating multilinear forms:

**Definition 7.1.13.** Let  $r, s \in \mathbb{N}$ , with  $r + s \leq N$ . The *wedge product* of  $e_{j_1}^* \wedge \cdots \wedge e_{j_r}^* \in \Lambda^r(\mathbb{R}^N)$  and  $e_{j_{r+1}}^* \wedge \cdots \wedge e_{j_{r+s}}^* \in \Lambda^s(\mathbb{R}^N)$  in  $\Lambda^{r+s}(\mathbb{R}^N)$  is defined via

$$\begin{aligned} & ((e_{j_1}^* \wedge \cdots \wedge e_{j_r}^*) \wedge (e_{j_{r+1}}^* \wedge \cdots \wedge e_{j_{r+s}}^*))(x_1, \dots, x_{r+s}) \\ & := \sum_{1 \leq j_1 < \cdots < j_{r+s} \leq N} \sum_{\sigma \in \mathfrak{S}_{r+s}} \operatorname{sgn} \sigma e_{j_{\sigma(1)}}^*(x_1) \cdots e_{j_{\sigma(r+s)}}^*(x_{r+s}) \end{aligned}$$

for  $x_1, \dots, x_{r+s} \in \mathbb{R}^N$ .

Given  $r, s \in \mathbb{N}$ ,  $r + s \leq N$ ,  $\omega \in \Lambda^r(\mathbb{R}^N)$ , and  $\phi \in \Lambda^s(\mathbb{R}^N)$ , we can use Theorem 7.1.10 to define  $\omega \wedge \phi \in \Lambda^{r+s}(\mathbb{R}^N)$  by means of linearity.

We record:

**Proposition 7.1.14.** Let  $r, s, t \in \mathbb{N}$ , let  $\lambda \in \mathbb{R}$ , and let  $\omega \in \Lambda^r(\mathbb{R}^N)$ ,  $\phi \in \Lambda^s(\mathbb{R}^N)$ , and  $\psi \in \Lambda^t(\mathbb{R}^N)$ . Then:

- (i)  $(\omega \wedge \phi) \wedge \psi = \omega \wedge (\phi \wedge \psi)$ ;
- (ii)  $\lambda(\omega \wedge \phi) = (\lambda\omega) \wedge \phi = \omega \wedge (\lambda\phi)$ ;
- (iii)  $(\omega + \phi) \wedge \psi = \omega \wedge \psi + \phi \wedge \psi$ ;
- (iv)  $\omega \wedge (\phi + \psi) = \omega \wedge \phi + \omega \wedge \psi$ ;
- (v)  $\omega \wedge \phi = (-1)^{rs} \phi \wedge \omega$ .

The verification is routine.

## Exercises

- Argue that the number  $n$  in Proposition 7.1.5 can be chosen to be less than or equal to  $r - 1$ .

## 7.2 Differential Forms

Let  $\emptyset \neq U \subset \mathbb{R}^N$  be open, and let  $r, p \in \mathbb{N}_0$ . By Corollary 7.1.11, we can canonically identify the vector spaces  $\Lambda^r(\mathbb{R}^N)$  and  $\mathbb{R}^{\binom{N}{r}}$ . Hence, it makes sense to speak of  $p$ -times continuously partially differentiable maps from  $U$  to  $\Lambda^r(\mathbb{R}^N)$ .

**Definition 7.2.1.** Let  $\emptyset \neq U \subset \mathbb{R}^N$  be open, and let  $r, p \in \mathbb{N}_0$ . A *differential  $r$ -form*—or short:  *$r$ -form*—of class  $\mathcal{C}^p$  on  $U$  is a  $\mathcal{C}^p$  function from  $U$  to  $\Lambda^r(\mathbb{R}^N)$ . The space of all  $r$ -forms of class  $\mathcal{C}^p$  is denoted by  $\Lambda^r(\mathcal{C}^p(U))$ .

*Remarks.* 1. A zero-form of class  $\mathcal{C}^p$  is simply a  $\mathcal{C}^p$  function with values in  $\mathbb{R}$ .

2. Let  $\omega \in \Lambda^r(\mathcal{C}^p(U))$ . Then there are unique functions  $f_{j_1, \dots, j_r} \in \mathcal{C}^p(U)$  for  $1 \leq j_1 < \dots < j_r \leq N$  such that

$$\omega(x) = \sum_{1 \leq j_1 < \dots < j_r \leq N} f_{j_1, \dots, j_r}(x) e_{j_1}^* \wedge \dots \wedge e_{j_r}^* \quad (7.3)$$

for all  $x \in U$ : this is immediate from Theorem 7.1.10. It is customary to use the symbol  $dx_j$  instead of  $e_j^*$ , for  $j = 1, \dots, N$ . Hence, (7.3) becomes

$$\omega(x) = \sum_{1 \leq j_1 < \dots < j_r \leq N} f_{j_1, \dots, j_r}(x) dx_{j_1} \wedge \dots \wedge dx_{j_r}$$

for all  $x \in U$ . We therefore write

$$\omega = \sum_{1 \leq j_1 < \dots < j_r \leq N} f_{j_1, \dots, j_r} dx_{j_1} \wedge \dots \wedge dx_{j_r}. \quad (7.4)$$

We call (7.4) the *standard representation* of  $\omega$ .

**Definition 7.2.2.** Let  $\emptyset \neq U \subset \mathbb{R}^N$  be open, let  $r, s, p \in \mathbb{N}_0$ , and let  $\omega \in \Lambda^r(\mathcal{C}^p(U))$ ,  $\phi \in \Lambda^s(\mathcal{C}^p(U))$ , and  $f \in \mathcal{C}^p(U)$ . Then  $\omega \wedge \phi \in \Lambda^{r+s}(\mathcal{C}^p(U))$  and  $f\omega \in \Lambda^r(\mathcal{C}^p(U))$  are defined for  $x \in U$  as:

- (a)  $(\omega \wedge \phi)(x) := \omega(x) \wedge \phi(x)$  if  $r, s \in \mathbb{N}$ ;
- (b)  $(\omega \wedge \phi)(x) := \omega(x)\phi(x)$  if  $r = 0$  or  $s = 0$ ;
- (c)  $(f\omega)(x) := f(x)\omega(x)$ .

In view of Proposition 7.1.14, we obtain:

**Proposition 7.2.3.** Let  $\emptyset \neq U \subset \mathbb{R}^N$  be open, let  $r, s, t, p \in \mathbb{N}_0$ , and let  $\omega \in \Lambda^r(\mathcal{C}^p(U))$ ,  $\phi \in \Lambda^s(\mathcal{C}^p(U))$ ,  $\psi \in \Lambda^t(\mathcal{C}^p(U))$ , and  $f \in \mathcal{C}^p(U)$ . Then:

- (i)  $(\omega \wedge \phi) \wedge \psi = \omega \wedge (\phi \wedge \psi)$ ;
- (ii)  $f(\omega \wedge \phi) = (f\omega) \wedge \phi = \omega \wedge (f\phi)$ ;
- (iii)  $(\omega + \phi) \wedge \psi = \omega \wedge \psi + \phi \wedge \psi$ ;
- (iv)  $\omega \wedge (\phi + \psi) = \omega \wedge \phi + \omega \wedge \psi$ ;
- (v)  $\omega \wedge \phi = (-1)^{rs} \phi \wedge \omega$ .

*Example.* Consider

$$\omega := xy^2 dx \wedge dy - z dy \wedge dz \in \Lambda^2(\mathcal{C}^0(\mathbb{R}^3)) \quad \text{and} \quad \phi := x dx + y dy + z dz \in \Lambda^1(\mathcal{C}^0(\mathbb{R}^3))$$

In view of Proposition 7.2.3, we obtain for  $\omega \wedge \phi \in \Lambda^3(\mathcal{C}^0(\mathbb{R}^3))$  that

$$\begin{aligned}\omega \wedge \phi &= x^2 y^2 \underbrace{dx \wedge dy \wedge dx}_{=0} + xy^3 \underbrace{dx \wedge dy \wedge dy}_{=0} + xy^2 z dx \wedge dy \wedge dz \\ &\quad - xz dy \wedge dz \wedge dx - yz \underbrace{dy \wedge dz \wedge dy}_{=0} - z^2 \underbrace{dy \wedge dz \wedge dz}_{=0} \\ &= xy^2 z dx \wedge dy \wedge dz - xz dy \wedge dz \wedge dx \\ &= (xy^2 z - xz) dx \wedge dy \wedge dz.\end{aligned}$$

**Definition 7.2.4.** Let  $\emptyset \neq U \subset \mathbb{R}^N$  be open. Then:

(a) the *differential* of  $f \in \mathcal{C}^1(U)$  is defined as

$$df := \sum_{j=1}^N \frac{\partial f}{\partial x_j} dx_j \in \Lambda^1(\mathcal{C}^0(U));$$

(b) the *outer differential* of  $\omega \in \Lambda^r(\mathcal{C}^1(U))$  with  $r \in \mathbb{N}$  in standard representation (7.4) is defined as

$$d\omega := \sum_{1 \leq j_1 < \dots < j_r \leq N} \sum_{j=1}^N \frac{\partial f_{j_1, \dots, j_r}}{\partial x_j} dx_j \wedge dx_{j_1} \wedge \dots \wedge dx_{j_r} \in \Lambda^{r+1}(\mathcal{C}^0(U)). \quad (7.5)$$

*Remark.* In view of the properties of  $\wedge$ , (7.5) is

$$d\omega = \sum_{1 \leq j_1 < \dots < j_r \leq N} df_{j_1, \dots, j_r} \wedge dx_{j_1} \wedge \dots \wedge dx_{j_r}.$$

*Examples.*

1. Let  $\emptyset \neq U \subset \mathbb{R}^2$  and  $\omega := P dx + Q dy \in \Lambda^1(\mathcal{C}^1(U))$ . Then

$$\begin{aligned}d\omega &= dP \wedge dx + dQ \wedge dy \\ &= \left( \frac{\partial P}{\partial x} dx + \frac{\partial P}{\partial y} dy \right) \wedge dx + \left( \frac{\partial Q}{\partial x} dx + \frac{\partial Q}{\partial y} dy \right) \wedge dy \\ &= \frac{\partial P}{\partial y} dy \wedge dx + \frac{\partial Q}{\partial x} dx \wedge dy \\ &= \left( \frac{\partial Q}{\partial x} - \frac{\partial P}{\partial y} \right) dx \wedge dy.\end{aligned}$$

2. Let  $\emptyset \neq U \subset \mathbb{R}^3$ , and let  $\omega := P dx + Q dy + R dz \in \Lambda^1(\mathcal{C}^1(U))$ . Then

$$\begin{aligned}
 d\omega &= dP \wedge dx + dQ \wedge dy + dR \wedge dz \\
 &= \left( \frac{\partial P}{\partial x} dx + \frac{\partial P}{\partial y} dy + \frac{\partial P}{\partial z} dz \right) \wedge dx + \left( \frac{\partial Q}{\partial x} dx + \frac{\partial Q}{\partial y} dy + \frac{\partial Q}{\partial z} dz \right) \wedge dy \\
 &\quad + \left( \frac{\partial R}{\partial x} dx + \frac{\partial R}{\partial y} dy + \frac{\partial R}{\partial z} dz \right) \wedge dz \\
 &= \frac{\partial P}{\partial y} dy \wedge dx + \frac{\partial P}{\partial z} dz \wedge dx + \frac{\partial Q}{\partial x} dx \wedge dy + \frac{\partial Q}{\partial z} dz \wedge dy \\
 &\quad + \frac{\partial R}{\partial x} dx \wedge dz + \frac{\partial R}{\partial y} dy \wedge dz \\
 &= \left( \frac{\partial R}{\partial y} - \frac{\partial Q}{\partial z} \right) dy \wedge dz + \left( \frac{\partial P}{\partial z} - \frac{\partial R}{\partial x} \right) dz \wedge dx + \left( \frac{\partial Q}{\partial x} - \frac{\partial P}{\partial y} \right) dx \wedge dy.
 \end{aligned}$$

3. Let  $\emptyset \neq U \subset \mathbb{R}^3$ , and let  $\omega := P dy \wedge dz + Q dz \wedge dx + R dx \wedge dy \in \Lambda^2(\mathcal{C}^1(U))$ . Then

$$\begin{aligned}
 d\omega &= dP \wedge dy \wedge dz + dQ \wedge dz \wedge dx + dR \wedge dx \wedge dy \\
 &= \left( \frac{\partial P}{\partial x} dx + \frac{\partial P}{\partial y} dy + \frac{\partial P}{\partial z} dz \right) \wedge dy \wedge dz \\
 &\quad + \left( \frac{\partial Q}{\partial x} dx + \frac{\partial Q}{\partial y} dy + \frac{\partial Q}{\partial z} dz \right) \wedge dz \wedge dx \\
 &\quad + \left( \frac{\partial R}{\partial x} dx + \frac{\partial R}{\partial y} dy + \frac{\partial R}{\partial z} dz \right) \wedge dx \wedge dy \\
 &= \frac{\partial P}{\partial x} dx \wedge dy \wedge dz + \frac{\partial Q}{\partial y} dy \wedge dz \wedge dx + \frac{\partial R}{\partial z} dz \wedge dx \wedge dy \\
 &= \left( \frac{\partial P}{\partial x} + \frac{\partial Q}{\partial y} + \frac{\partial R}{\partial z} \right) dx \wedge dy \wedge dz.
 \end{aligned}$$

The following holds:

**Proposition 7.2.5.** *Let  $\emptyset \neq U \subset \mathbb{R}^N$  be open, let  $r, s \in \mathbb{N}_0$ , let  $\omega \in \Lambda^r(\mathcal{C}^1(U))$  and  $\phi \in \Lambda^s(\mathcal{C}^1(U))$ , and let  $\lambda \in \mathbb{R}$ . Then:*

- (i)  $d(\omega + \phi) = d\omega + d\phi$  if  $r = s$ ;
- (ii)  $d(\lambda\omega) = \lambda d\omega$ ;
- (iii)  $d(\omega \wedge \phi) = d\omega \wedge \phi + (-1)^r \omega \wedge d\phi$ .

*Proof.* (i) and (ii) are routine.

For (iii), only consider the case where  $r, s \in \mathbb{N}$ ; the case where  $r = 0$  or  $s = 0$  is similar. In view of Proposition 7.2.3, we can suppose without loss of generality that

$$\omega = f dx_{j_1} \wedge \cdots \wedge dx_{j_r} \quad \text{and} \quad \phi = g dx_{k_1} \wedge \cdots \wedge dx_{k_s},$$



with  $f, g \in \mathcal{C}^1(U)$  and  $1 \leq j_1 < \cdots < j_r \leq N$  and  $1 \leq k_1 < \cdots < k_s \leq N$ . It follows that

$$\omega \wedge \phi = fg \underbrace{dx_{j_1} \wedge \cdots \wedge dx_{j_r}}_{=: \alpha} \wedge \underbrace{dx_{k_1} \wedge \cdots \wedge dx_{k_s}}_{=: \beta},$$

so that

$$\begin{aligned} d(\omega \wedge \phi) &= d(fg) \wedge \alpha \wedge \beta \\ &= g df \wedge \alpha \wedge \beta + f dg \wedge \alpha \wedge \beta, && \text{because } d(fg) = g df + f dg, \\ &= (df \wedge \alpha) \wedge (g\beta) + dg \wedge f\alpha \wedge \beta \\ &= (df \wedge \alpha) \wedge (g\beta) + (-1)^r (f\alpha) \wedge (dg \wedge \beta), && \text{by Proposition 7.2.3(v),} \\ &= d\omega \wedge \phi + (-1)^r \omega \wedge d\phi. \end{aligned}$$

This proves the claim.  $\square$

**Theorem 7.2.6.** *Let  $\emptyset \neq U \subset \mathbb{R}^N$  be open, let  $r \in \mathbb{N}_0$ , and let  $\omega \in \Lambda^r(\mathcal{C}^2(U))$ . Then  $d(d\omega) = 0$ .*

*Proof.* Suppose first that  $r = 0$ , i.e.,  $\omega = f \in \mathcal{C}^2(U)$ . Then

$$\begin{aligned} d(d\omega) &= d\left(\sum_{j=1}^N \frac{\partial f}{\partial x_j} dx_j\right) \\ &= \sum_{j=1}^N \sum_{k=1}^N \frac{\partial^2 f}{\partial x_k \partial x_j} dx_k \wedge dx_j \\ &= \sum_{\substack{j,k=1 \\ j \neq k}}^N \frac{\partial^2 f}{\partial x_k \partial x_j} dx_k \wedge dx_j \\ &= \sum_{1 \leq j < k \leq N} \left( \frac{\partial^2 f}{\partial x_k \partial x_j} - \frac{\partial^2 f}{\partial x_j \partial x_k} \right) dx_k \wedge dx_j \\ &= 0 \end{aligned}$$

by Clairaut's Theorem.

Let  $r \in \mathbb{N}$ . Without loss of generality, we can suppose that

$$\omega = f \underbrace{dx_{j_1} \wedge \cdots \wedge dx_{j_r}}_{=: \alpha}$$

with  $f \in \mathcal{C}^2(U)$  and  $1 \leq j_1 < \cdots < j_r \leq N$ . From Proposition 7.2.5(iii), we conclude that

$$d(d\omega) = d(df \wedge \alpha) = d(df) \wedge \alpha - df \wedge d\alpha.$$

As  $d(df) = 0$  by the foregoing and  $d\alpha = 0$  for trivial reasons, we obtain  $d(d\omega) = 0$ .  $\square$

**Definition 7.2.7.** Let  $\emptyset \neq V \subset \mathbb{R}^M$  and  $\emptyset \neq U \subset \mathbb{R}^N$  be open,  $T = (t_1, \dots, t_N): V \rightarrow U$  be of class  $\mathcal{C}^1$ ,  $r \in \mathbb{N}_0$ , and  $\omega \in \Lambda^r(\mathcal{C}^0(U))$ . Then the  $T$ -pullback  $\omega_T \in \Lambda^r(\mathcal{C}^0(V))$  of  $\omega$  is defined as follows:

- (a) if  $r = 0$ , i.e.,  $\omega = f \in \mathcal{C}^0(U)$ , then  $\omega_T = f_T = f \circ T$ ;  
 (b) if  $r \in \mathbb{N}$  and  $\omega$  is in standard form (7.4), then

$$\omega_T := \sum_{1 \leq j_1 < \dots < j_r \leq N} (f_{j_1, \dots, j_r} \circ T) dt_{j_1} \wedge \dots \wedge dt_{j_r},$$

where

$$dt_j = \sum_{k=1}^M \frac{\partial t_j}{\partial x_k} dx_k$$

for  $j = 1, \dots, N$ .

**Proposition 7.2.8.** Let  $\emptyset \neq V \subset \mathbb{R}^M$  and  $\emptyset \neq U \subset \mathbb{R}^N$  be open, let  $T = (t_1, \dots, t_N): V \rightarrow U$  be of class  $\mathcal{C}^1$ , let  $r, s \in \mathbb{N}_0$ , and let  $\omega \in \Lambda^r(\mathcal{C}^0(U))$  and  $\phi \in \Lambda^s(\mathcal{C}^0(U))$ . Then:

- (i)  $(\omega + \phi)_T = \omega_T + \phi_T$  if  $r = s$ ;  
 (ii)  $(\omega \wedge \phi)_T = \omega_T \wedge \phi_T$ ;  
 (iii)  $d\omega_T = (d\omega)_T$  if  $\omega \in \Lambda^r(\mathcal{C}^1(U))$  and  $T \in \mathcal{C}^2(V, \mathbb{R}^N)$ .

*Proof.* (i) and (ii) are routine.

For (iii), suppose first that  $\omega = f \in \mathcal{C}^1(U)$ . Then

$$\begin{aligned} df_T &= \sum_{j=1}^M \frac{\partial(f \circ T)}{\partial x_j} dx_j \\ &= \sum_{j=1}^M \left( \sum_{k=1}^N \left( \frac{\partial f}{\partial y_k} \circ T \right) \frac{\partial t_k}{\partial x_j} \right) dx_j \\ &= \sum_{k=1}^N \left( \left( \frac{\partial f}{\partial y_k} \circ T \right) \sum_{j=1}^M \frac{\partial t_k}{\partial x_j} dx_j \right) \\ &= \sum_{k=1}^N \left( \frac{\partial f}{\partial y_k} \circ T \right) dt_k \\ &= (df)_T, \end{aligned}$$

so that the claim is settled in this case.

For the case where  $r \in \mathbb{N}$ , we suppose again that

$$\omega = f \underbrace{dx_{j_1} \wedge \dots \wedge dx_{j_r}}_{=: \alpha},$$

with  $f \in \mathcal{C}^1(U)$  and  $1 \leq j_1 < \cdots < j_r \leq N$ . We note that  $\alpha_T = dt_{j_1} \wedge \cdots \wedge dt_{j_r}$  and therefore  $d\alpha_T = 0$  by Exercise 6 on pg. 228. It follows that

$$d\omega_T = df_T \wedge \alpha_T + f_T d\alpha_T = df_T \wedge \alpha_T = (df)_T \wedge \alpha_T = (df \wedge \alpha)_T = (d\omega)_T,$$

which proves the claim.  $\square$

**Proposition 7.2.9.** *Let  $\emptyset \neq W \subset \mathbb{R}^K$ ,  $\emptyset \neq V \subset \mathbb{R}^M$ , and  $\emptyset \neq U \subset \mathbb{R}^N$  be open, let  $T = (t_1, \dots, t_M) : W \rightarrow V$  and  $S = (s_1, \dots, s_N) : V \rightarrow U$ , let  $r \in \mathbb{N}_0$ , and let  $\omega \in \Lambda^r(\mathcal{C}^0(U))$ . Then  $(\omega_S)_T = \omega_{S \circ T}$ .*

*Proof.* The claim is obvious for  $r = 0$ . For  $r \in \mathbb{N}$ , we can suppose without loss of generality that  $\omega = dz_j$  with  $j \in \{1, \dots, N\}$ : this follows from the standard representation (7.4) of  $\omega$  and Proposition 7.2.8. In this case, by definition,

$$(dz_j)_S = ds_j = \sum_{k=1}^M \frac{\partial s_j}{\partial y_k} dy_k$$

and, consequently,

$$\begin{aligned} ((dz_j)_S)_T &= \sum_{k=1}^M \left( \frac{\partial s_j}{\partial y_k} \circ T \right) dt_k \\ &= \sum_{k=1}^M \left( \frac{\partial s_j}{\partial y_k} \circ T \right) \sum_{\nu=1}^K \frac{\partial t_k}{\partial x_\nu} dx_\nu \\ &= \sum_{\nu=1}^K \left( \sum_{k=1}^M \left( \frac{\partial s_j}{\partial y_k} \circ T \right) \frac{\partial t_k}{\partial x_\nu} \right) dx_\nu. \end{aligned}$$

On the other hand, let  $u_1, \dots, u_N \in \mathcal{C}^1(W)$  be the coordinate functions of  $S \circ T$ . Then

$$\begin{aligned} (dz_j)_{S \circ T} &= du_j \\ &= \sum_{\nu=1}^K \frac{\partial u_j}{\partial x_\nu} dx_\nu \\ &= \sum_{\nu=1}^K \left( \sum_{k=1}^M \left( \frac{\partial s_j}{\partial y_k} \circ T \right) \frac{\partial t_k}{\partial x_\nu} \right) dx_\nu, \end{aligned}$$

so that  $((dz_j)_S)_T = (dz_j)_{S \circ T}$ .  $\square$

### Exercises

1. Let

$$\omega := \sin(xy) dx + e^{xz} dy - zx dz \quad \text{and} \quad \phi := xyz dx \wedge dz + \cos z dx \wedge dy.$$

Compute  $\omega \wedge \phi$  and  $d(\omega \wedge \phi)$ , expressing both differential forms in their respective standard representations.

2. Let  $\emptyset \neq U \subset \mathbb{R}^N$  be open, let  $r, s \in \mathbb{N}_0$ , and let  $\omega \in \Lambda^r(\mathcal{C}^2(U))$  and  $\phi \in \Lambda^s(\mathcal{C}^2(U))$ . Compute

$$d(d\omega \wedge \phi - \omega \wedge d\phi).$$

3. Let  $\emptyset \neq U \subset \mathbb{R}^N$  be open, and let  $f = (f_1, \dots, f_N) \in \mathcal{C}^1(U, \mathbb{R}^N)$ . Show that

$$df_1 \wedge \cdots \wedge df_N = \det J_f dx_1 \wedge \cdots \wedge dx_N.$$

4. Let  $\emptyset \neq U \subset \mathbb{R}^N$  be open, and let  $r \in \mathbb{N}_0$ . Then  $\omega \in \Lambda^r(\mathcal{C}^1(U))$  is called *closed* if  $d\omega = 0$ . Show that:

- (a) each  $\omega \in \Lambda^N(\mathcal{C}^1(U))$  is closed;  
 (b)  $\omega = \sum_{j=1}^N f_j dx_j \in \Lambda^1(\mathcal{C}^1(U))$  is closed if and only if

$$\frac{\partial f_j}{\partial x_k} = \frac{\partial f_k}{\partial x_j}$$

on  $U$  for all  $j, k = 1, \dots, N$ .

5. Let  $\emptyset \neq U \subset \mathbb{R}$  be open, let  $r, s \in \mathbb{N}_0$ , and let  $\omega \in \Lambda^r(\mathcal{C}^1(U))$  and  $\phi \in \Lambda^s(\mathcal{C}^1(U))$  be closed. Show that  $\omega \wedge \phi$  is closed.
6. Let  $\emptyset \neq U \subset \mathbb{R}^N$  be open, and let  $f_1, \dots, f_n \in \mathcal{C}^2(U)$ . Show that  $df_1 \wedge \cdots \wedge df_n$  is closed. (*Hint*: Use induction on  $n$ .)
7. Let  $\emptyset \neq U \subset \mathbb{R}^N$  be open, and let  $r \in \mathbb{N}$ . Then  $\omega \in \Lambda^r(\mathcal{C}^0(U))$  is called *exact* if there is  $\phi \in \Lambda^{r-1}(\mathcal{C}^1(U))$  such that  $\omega = d\phi$ . Show that:
- (a) if  $\omega \in \Lambda^r(\mathcal{C}^1(U))$  is exact, then it is closed;  
 (b) if  $U$  is star shaped and  $\omega \in \Lambda^1(\mathcal{C}^1(U))$  is closed, then  $\omega$  is exact.

### 7.3 Integration of Differential Forms

**Definition 7.3.1.** Let  $U \subset \mathbb{R}^r$  be open, and let  $\emptyset \neq K \subset U$  be compact and with content. An  $r$ -surface  $\Phi$  of class  $\mathcal{C}^p$  in  $\mathbb{R}^N$  with parameter domain  $K$  is the restriction of a  $\mathcal{C}^p$ -function  $\Phi: U \rightarrow \mathbb{R}^N$  to  $K$ . The set  $K$  is called the *parameter domain* of  $\Phi$ , and  $\{\Phi\} := \Phi(K)$  is called the *trace* or the *surface element* of  $\Phi$ .

**Definition 7.3.2.** Let  $r \in \mathbb{N}$ , let  $\Phi = (\phi_1, \dots, \phi_N)$  be an  $r$ -surface of class  $\mathcal{C}^1$  in  $\mathbb{R}^N$  with parameter domain  $K$ , and let  $\omega$  be an  $r$ -form of class  $\mathcal{C}^0$  on a neighborhood of  $\{\Phi\}$  with a unique representation as in (7.4). Then the *surface integral of  $\omega$  over  $\Phi$*  is defined as

$$\int_{\Phi} \omega := \sum_{1 \leq j_1 < \cdots < j_r \leq N} \int_K (f_{j_1, \dots, j_r} \circ \Phi) \begin{vmatrix} \frac{\partial \phi_{j_1}}{\partial x_1} & \cdots & \frac{\partial \phi_{j_1}}{\partial x_r} \\ \vdots & \ddots & \vdots \\ \frac{\partial \phi_{j_r}}{\partial x_1} & \cdots & \frac{\partial \phi_{j_r}}{\partial x_r} \end{vmatrix}.$$

*Examples.*

1. Let  $N$  be arbitrary, and let  $r = 1$ . Then  $\omega$  is of the form

$$\omega = f_1 dx_1 + \cdots + f_N dx_N.$$

Let  $a < b$ , and let  $\gamma = (\gamma_1, \dots, \gamma_N) : [a, b] \rightarrow \mathbb{R}^N$  be a  $\mathcal{C}^1$ -curve. Let  $\epsilon > 0$ . For  $j = 1, \dots, N$ , define

$$\bar{\gamma}'_j : (a - \epsilon, b + \epsilon) \rightarrow \mathbb{R}, \quad t \mapsto \begin{cases} \gamma'_j(a), & a - \epsilon < t \leq a, \\ \gamma'_j(t), & a \leq t \leq b, \\ \gamma'_j(b), & b \leq t < b + \epsilon. \end{cases}$$

Then  $\bar{\gamma}'_1, \dots, \bar{\gamma}'_N$  are continuous and extend  $\gamma'_1, \dots, \gamma'_N$ . It follows that, for  $j = 1, \dots, N$ , the functions

$$\bar{\gamma}_j : (a - \epsilon, b + \epsilon) \rightarrow \mathbb{R}, \quad t \mapsto \gamma_j(a) + \int_a^t \bar{\gamma}'_j(s) ds$$

are of class  $\mathcal{C}^1$  and extend  $\gamma_1, \dots, \gamma_N$ , respectively. Set  $U := (a - \epsilon, b + \epsilon)$ ,  $K := [a, b]$ , and define

$$\Phi : U \rightarrow \mathbb{R}^N, \quad t \mapsto (\bar{\gamma}_1, \dots, \bar{\gamma}_N).$$

Then  $\Phi$  is a  $\mathcal{C}^1$ -curve  $\gamma$ , and

$$\int_K \omega = \sum_{j=1}^N \int_a^b f_j(\gamma(t)) \gamma'_j(t) dt = \int_\gamma f_1 dx_1 + \cdots + f_N dx_N,$$

i.e., the curve integral of the vector field  $(f_1, \dots, f_N)$  along the curve  $\gamma$  as described in Theorem 6.2.4 is a special case of Definition 7.3.2.

2. Let  $N = 3$ , and let  $r = 2$ , i.e.,  $\Phi$  is a surface in the sense of Definition 6.4.1. The normal vector to  $\Phi$  at  $\Phi(s, t)$  with  $(s, t)$  in the parameter domain  $K$  of  $\Phi$  is

$$N(s, t) = \left( \left| \begin{array}{cc} \frac{\partial \phi_2}{\partial s}(s, t) & \frac{\partial \phi_3}{\partial s}(s, t) \\ \frac{\partial \phi_2}{\partial t}(s, t) & \frac{\partial \phi_3}{\partial t}(s, t) \end{array} \right|, - \left| \begin{array}{cc} \frac{\partial \phi_1}{\partial s}(s, t) & \frac{\partial \phi_3}{\partial s}(s, t) \\ \frac{\partial \phi_1}{\partial t}(s, t) & \frac{\partial \phi_3}{\partial t}(s, t) \end{array} \right|, \left| \begin{array}{cc} \frac{\partial \phi_1}{\partial s}(s, t) & \frac{\partial \phi_2}{\partial s}(s, t) \\ \frac{\partial \phi_1}{\partial t}(s, t) & \frac{\partial \phi_2}{\partial t}(s, t) \end{array} \right| \right).$$

Given a continuous vector field  $f = (P, Q, R)$  defined on a neighborhood of  $\{\Phi\}$  the surface integral of  $f$  over  $\Phi$  in the sense of Definition 6.6.2 is

$$\begin{aligned} & \int_\Phi P dy \wedge dz + Q dz \wedge dx + R dx \wedge dy \\ &= \int_K (f \circ \Phi) \cdot N \\ &= \int_K (P \circ \Phi) \left| \begin{array}{cc} \frac{\partial \phi_2}{\partial s} & \frac{\partial \phi_3}{\partial s} \\ \frac{\partial \phi_2}{\partial t} & \frac{\partial \phi_3}{\partial t} \end{array} \right| - (Q \circ \Phi) \left| \begin{array}{cc} \frac{\partial \phi_1}{\partial s} & \frac{\partial \phi_3}{\partial s} \\ \frac{\partial \phi_1}{\partial t} & \frac{\partial \phi_3}{\partial t} \end{array} \right| + (R \circ \Phi) \left| \begin{array}{cc} \frac{\partial \phi_1}{\partial s} & \frac{\partial \phi_2}{\partial s} \\ \frac{\partial \phi_1}{\partial t} & \frac{\partial \phi_2}{\partial t} \end{array} \right| \\ &= \int_\Phi \omega, \end{aligned}$$

with the last integral being in the sense of Definition 7.3.2, where

$$\omega := P dy \wedge dz - Q dx \wedge dz + R dx \wedge dy = P dy \wedge dz + Q dz \wedge dx + R dx \wedge dy.$$

So, the meanings assigned to the symbol

$$\int_{\Phi} P dy \wedge dz + Q dz \wedge dx + R dx \wedge dy$$

by Definitions 7.3.2 and 6.6.2 are identical.

The following is straightforward:

**Lemma 7.3.3.** *Let  $\Phi$  be an  $r$ -surface of class  $\mathcal{C}^1$  with parameter domain  $K$ , and let  $\omega_1$  and  $\omega_2$  be  $r$ -forms of class  $\mathcal{C}^0$  on an open neighborhood of  $\{\Phi\}$ , and let  $\lambda_1, \lambda_2 \in \mathbb{R}$ . Then*

$$\int_{\Phi} \lambda_1 \omega_1 + \lambda_2 \omega_2 = \lambda_1 \int_{\Phi} \omega_1 + \lambda_2 \int_{\Phi} \omega_2.$$

**Lemma 7.3.4.** *Let  $r \in \mathbb{N}$ , let  $\emptyset \neq U \subset \mathbb{R}^N$  be open, let  $\omega \in \Lambda^r(\mathcal{C}^0(U))$ ,  $\Phi = (\phi_1, \dots, \phi_N)$  be an  $r$ -surface of class  $\mathcal{C}^1$  in  $\mathbb{R}^N$  with parameter domain  $K$  such that  $\{\Phi\} \subset U$ , and let  $\Psi$  be the restriction of the identity map on  $\mathbb{R}^r$  to  $K$ . Then*

$$\int_{\Phi} \omega = \int_{\Psi} \omega_{\Phi}.$$

*Proof.* In view of Lemma 7.3.3, we can limit ourselves to the case where

$$\omega = f dx_{j_1} \wedge \cdots \wedge dx_{j_r},$$

with  $f \in \mathcal{C}^0(U)$  and  $1 \leq j_1 < \cdots < j_r \leq N$ , so that

$$\begin{aligned} \omega_{\Phi} &= (f \circ \Phi) d\phi_{j_1} \wedge \cdots \wedge d\phi_{j_r} \\ &= (f \circ \Phi) \begin{vmatrix} \frac{\partial \phi_{j_1}}{\partial x_1} & \cdots & \frac{\partial \phi_{j_1}}{\partial x_r} \\ \vdots & \ddots & \vdots \\ \frac{\partial \phi_{j_r}}{\partial x_1} & \cdots & \frac{\partial \phi_{j_r}}{\partial x_r} \end{vmatrix} dx_1 \wedge \cdots \wedge dx_r, \end{aligned} \quad (7.6)$$

with the last equality being due to Exercise 3. Consequently, we obtain

$$\begin{aligned} \int_{\Psi} \omega_{\Phi} &= \int_{\Psi} (f \circ \Phi) \begin{vmatrix} \frac{\partial \phi_{j_1}}{\partial x_1} & \cdots & \frac{\partial \phi_{j_1}}{\partial x_r} \\ \vdots & \ddots & \vdots \\ \frac{\partial \phi_{j_r}}{\partial x_1} & \cdots & \frac{\partial \phi_{j_r}}{\partial x_r} \end{vmatrix} dx_1 \wedge \cdots \wedge dx_r \\ &= \int_K (f \circ \Phi) \begin{vmatrix} \frac{\partial \phi_{j_1}}{\partial x_1} & \cdots & \frac{\partial \phi_{j_1}}{\partial x_r} \\ \vdots & \ddots & \vdots \\ \frac{\partial \phi_{j_r}}{\partial x_1} & \cdots & \frac{\partial \phi_{j_r}}{\partial x_r} \end{vmatrix} dx_1 \wedge \cdots \wedge dx_r \\ &= \int_{\Phi} \omega, \end{aligned}$$

which proves the claim.  $\square$

**Theorem 7.3.5.** Let  $\emptyset \neq V \subset \mathbb{R}^M$  and  $\emptyset \neq U \subset \mathbb{R}^N$  be open, let  $r \in \mathbb{N}$ , let  $\omega \in \Lambda^r(\mathcal{C}^0(V))$ , let  $\Phi$  be an  $r$ -surface of class  $\mathcal{C}^1$  with  $\{\Phi\} \subset V$ , and let  $T \in \mathcal{C}^1(V, \mathbb{R}^N)$  with  $T(V) \subset U$ . Then

$$\int_{T \circ \Phi} \omega = \int_{\Phi} \omega_T.$$

*Proof.* Let  $\Psi$  be as in Lemma 7.3.4, so that by that lemma

$$\int_{T \circ \Phi} \omega = \int_{\Psi} \omega_{T \circ \Phi} \quad \text{and} \quad \int_{\Phi} \omega_T = \int_{\Psi} (\omega_T)_{\Phi}.$$

As  $(\omega_T)_{\Phi} = \omega_{T \circ \Phi}$  by Proposition 7.2.9, this proves the claim.  $\square$

## 7.4 Simplices and Chains

**Definition 7.4.1.** The *unit simplex* in  $\mathbb{R}^N$  is defined as

$$\Sigma_N := \left\{ (x_1, \dots, x_N) \in \mathbb{R}^N : x_1, \dots, x_N \geq 0, \sum_{j=1}^N x_j \leq 1 \right\}$$

*Examples.*

1.  $\Sigma_1 = [0, 1]$ .
2.  $\Sigma_2$  is the triangle with vertices  $0$ ,  $\mathbf{i}$  and  $\mathbf{j}$ .
3.  $\Sigma_3$  is the tetrahedron with vertices  $0$ ,  $\mathbf{i}$ ,  $\mathbf{j}$ , and  $\mathbf{k}$ .

**Definition 7.4.2.** Let  $r \in \mathbb{N}$ , and let  $(x_0, x_1, \dots, x_r) \in (\mathbb{R}^N)^{r+1}$ . Then the *oriented affine  $r$ -simplex*  $[x_0, x_1, \dots, x_r]$  is the  $r$ -surface in  $\mathbb{R}^N$  with parameter domain  $\Sigma_r$  given by

$$[x_0, x_1, \dots, x_r] : \mathbb{R}^r \rightarrow \mathbb{R}^N, \quad (t_1, \dots, t_r) \mapsto x_0 + t_1(x_1 - x_0) + \dots + t_r(x_r - x_0).$$

The points  $x_0, x_1, \dots, x_r$  are called the *vertices* of  $[x_0, x_1, \dots, x_r]$ .

*Remark.* Note that the unit simplex in  $\mathbb{R}^N$  is *not* an oriented affine simplex in the sense of Definition 7.4.2: the former is a set, the latter a (restriction of a) map.

**Definition 7.4.3.** Let  $r \in \mathbb{N}$ . Then we call  $\sigma \in \mathfrak{S}_r$  *even* if  $\text{sgn } \sigma = 1$  and *odd* if  $\text{sgn } \sigma = -1$ .

**Definition 7.4.4.** Let  $(x_0, x_1, \dots, x_r), (y_0, y_1, \dots, y_r) \in \mathbb{R}^N$ . Then we call  $[x_0, x_1, \dots, x_r]$  and  $[y_0, y_1, \dots, y_r]$  *equivalent*—in symbols:  $[x_0, x_1, \dots, x_r] \sim [y_0, y_1, \dots, y_r]$ —if there is an even  $\sigma \in \mathfrak{S}_{r+1}$  such that  $y_j = x_{\sigma(j)}$  for  $j = 0, 1, \dots, r$ . We set

$$[[x_0, x_1, \dots, x_r]] := \{[y_0, y_1, \dots, y_r] : [x_0, x_1, \dots, x_r] \sim [y_0, y_1, \dots, y_r]\}$$

*Remarks.* 1. Definition 7.4.4 partitions  $\{[x_{\sigma(0)}, x_{\sigma(1)}, \dots, x_{\sigma(r)}] : \sigma \in \mathfrak{S}_{r+1}\}$  into two equivalence classes, namely  $[[x_0, x_1, \dots, x_r]]$  and

$$-[[x_0, x_1, \dots, x_r]] := \{[x_{\sigma(0)}, x_{\sigma(1)}, \dots, x_{\sigma(r)}] : \sigma \in \mathfrak{S}_{r+1}, \sigma \text{ odd}\}.$$

2. For convenience, if  $\Sigma = [x_0, x_1, \dots, x_r]$ , we write  $[[\Sigma]]$  for  $[[x_0, x_1, \dots, x_r]]$  and  $-[[\Sigma]]$  for  $-[[x_0, x_1, \dots, x_r]]$ .

So far, oriented affine  $r$ -simplices were defined only for  $r \in \mathbb{N}$ . For formal reasons, we now define:

**Definition 7.4.5.** An *oriented affine 0-simplex* in  $\mathbb{R}^N$  is a pair  $(\varepsilon, x_0)$  with  $\varepsilon \in \{-1, 1\}$  and  $x_0 \in \mathbb{R}^N$ . We write

$$[x_0] := (1, x_0), \quad -[x_0] := (-1, x_0), \quad \text{and} \quad [[x_0]] := [x_0].$$

**Definition 7.4.6.** Let  $r \in \mathbb{N}_0$ . An *affine  $r$ -chain* in  $\mathbb{R}^N$  is a formal sum  $[[\Sigma_1]] \oplus \dots \oplus [[\Sigma_m]]$  where  $\Sigma_1, \dots, \Sigma_m$  are oriented affine  $r$ -simplices in  $\mathbb{R}^N$ .

*Remarks.* 1. Somewhat abusing notation, we will also write  $[[\Sigma_1 \oplus \dots \oplus \Sigma_m]]$  for oriented affine  $r$ -simplices  $\Sigma_1, \dots, \Sigma_m$  in  $\mathbb{R}^N$  or even  $\Sigma_1 \oplus \dots \oplus \Sigma_m$ .

2. Given oriented affine  $r$ -simplices  $\Sigma_1, \dots, \Sigma_m$  in  $\mathbb{R}^N$  and  $\varepsilon_1, \dots, \varepsilon_m \in \{-1, 1\}$ , we stipulate that  $\varepsilon_1 \Sigma_1 \oplus \dots \oplus \varepsilon_m \Sigma_m$  denotes  $\varepsilon_1 [[\Sigma_1]] \oplus \dots \oplus \varepsilon_m [[\Sigma_m]]$ .

**Definition 7.4.7.** Let  $r \in \mathbb{N}$ , and let  $\Sigma := [x_0, x_1, \dots, x_r]$  be an oriented affine  $r$ -simplex in  $\mathbb{R}^N$ . Then the *oriented boundary* of  $\Sigma$  is defined as

$$\partial\Sigma := \bigoplus_{j=0}^r (-1)^j [x_0, \dots, x_{j-1}, x_{j+1}, \dots, x_r].$$

*Remark.* Obviously,  $\partial\Sigma$  is an affine  $(r-1)$ -chain.

*Examples.*

1. If  $\Sigma = [x_0, x_1]$ , then  $\partial\Sigma = [x_1] \oplus (-[x_0])$ .
2. If  $\Sigma = [x_0, x_1, x_2]$ , so that  $\{[x_0, x_1, x_2]\}$ , is the triangle with vertices  $x_0, x_1$ , and  $x_2$ , then

$$\partial\Sigma = [x_1, x_2] \oplus (-[x_0, x_2]) \oplus [x_0, x_1] = [x_0, x_1] \oplus [x_1, x_2] \oplus [x_2, x_0],$$

i.e., the topological boundary of that triangle in counterclockwise orientation.

**Definition 7.4.8.** Let  $r \in \mathbb{N}$ . An *oriented  $r$ -simplex* in  $\mathbb{R}^N$  is an  $r$ -surface  $\Phi$  of the form  $T \circ \Sigma$  such that:



- (a)  $\Sigma$  is an oriented affine  $r$ -simplex in  $\mathbb{R}^M$ ;
- (b)  $T$  is a  $\mathcal{C}^2$ -map defined on an open neighborhood of  $\{\Sigma\}$ .

*Remarks.* 1. If  $\Phi_1$  and  $\Phi_2$  are two oriented  $r$ -simplices of the form  $T \circ \Sigma_1$  and  $T \circ \Sigma_2$ , respectively, we define

$$\Phi_1 \sim \Phi_2 \quad :\iff \quad \Sigma_1 \sim \Sigma_2$$

and denote the corresponding equivalence class by  $[[\Phi_1]]$ .

2. As for oriented affine  $r$ -simplices, we have—given an oriented  $r$ -simplex  $\Phi = T \circ \Sigma$ —there are two equivalence classes denoted by  $[[\Phi]]$  and  $-[[\Phi]]$ .
3. We write  $T \circ [[\Sigma]]$  for  $[[T \circ \Sigma]]$ : this is clearly well defined.

**Definition 7.4.9.** An *oriented 0-simplex* in  $\mathbb{R}^N$  is a pair  $(\varepsilon, T(x_0))$  with  $\varepsilon \in \{-1, 1\}$ ,  $x_0 \in \mathbb{R}^M$ , and  $T$  is a  $\mathcal{C}^2$ -map into  $\mathbb{R}^N$  defined on a neighborhood of  $x_0$ . We write

$$T \circ [x_0] := (1, x_0), \quad -T \circ [x_0] := (-1, x_0), \quad \text{and} \quad [[T \circ x_0]] := T \circ [x_0].$$

**Definition 7.4.10.** Let  $r \in \mathbb{N}_0$ . An  *$r$ -chain* in  $\mathbb{R}^N$  is a formal sum  $[[\Phi_1]] \oplus \cdots \oplus [[\Phi_m]]$  where  $\Phi_1, \dots, \Phi_m$  are oriented  $r$ -simplices in  $\mathbb{R}^N$  of the form  $T \circ \Sigma_j$  for  $j = 1, \dots, m$  where  $\Sigma_1, \dots, \Sigma_m$  are oriented affine  $r$ -simplices in  $\mathbb{R}^M$  and  $T$  is a  $\mathcal{C}^2$ -map defined on an open neighborhood of  $\{\Sigma_1\} \cup \cdots \cup \{\Sigma_m\}$ . The *trace* or *surface element* of  $[[\Phi_1]] \oplus \cdots \oplus [[\Phi_m]]$  is defined as

$$\{[[\Phi_1]] \oplus \cdots \oplus [[\Phi_m]]\} := \{\Phi_1\} \cup \cdots \cup \{\Phi_m\}.$$

*Remark.* Given  $\Phi_1 = T \circ \Sigma_1$  and  $\Phi_2 = T \circ \Sigma_2$ , we write  $[[\Phi_1]] = -[[\Phi_2]]$  if  $[[\Sigma_1]] = -[[\Sigma_2]]$

**Definition 7.4.11.** Let  $r \in \mathbb{N}$ . Then:

- (a) if  $\Phi$  is an oriented  $r$ -simplex  $\Phi = T \circ \Sigma$  in  $\mathbb{R}^N$ , the *oriented boundary* of  $\Phi$  is defined as the  $(r-1)$ -chain

$$\partial\Phi := \bigoplus_{j=0}^r (-1)^j T \circ [x_0, \dots, x_{j-1}, x_{j+1}, \dots, x_r].$$

- (b) if  $\Phi_1, \dots, \Phi_m$  are oriented  $r$ -simplices in  $\mathbb{R}^N$ , then the *oriented boundary* of  $\Phi := \Phi_1 \oplus \cdots \oplus \Phi_m$  is defined as

$$\partial\Phi := \partial\Phi_1 \oplus \cdots \oplus \partial\Phi_m.$$

*Remark.* We stipulate that, whenever in an expression  $\Phi_1 \oplus \cdots \oplus \Phi_m$ , there are  $1 \leq j < k \leq m$  with  $\Phi_k = -\Phi_j$ , then  $\Phi_j$  and  $\Phi_k$  cancel each other. Also, we agree to omit  $\Phi_j$  whenever  $\Phi_j = 0$ .

*Examples.*

1. Consider the 3-chain  $[x_0, x_1, x_2] \oplus [x_1, x_3, x_2]$  in  $\mathbb{R}^N$  with  $x_0, x_1, x_2, x_3 \in \mathbb{R}^N$ ; its trace is the convex hull of  $x_0, x_1, x_2$ , and  $x_3$ . Then

$$\begin{aligned} & \partial([x_0, x_1, x_2] \oplus [x_1, x_3, x_2]) \\ &= \partial[x_0, x_1, x_2] \oplus \partial[x_1, x_3, x_2] \\ &= [x_0, x_1] \oplus [x_1, x_2] \oplus [x_2, x_2] \oplus [x_1, x_3] \oplus [x_3, x_2] \oplus [x_2, x_1], \\ & \qquad \qquad \qquad \text{by the second Example after Definition 7.4.7,} \\ &= [x_0, x_1] \oplus [x_1, x_2] \oplus [x_2, x_0] \oplus [x_1, x_3] \oplus [x_3, x_2] \oplus (-[x_1, x_2]), \\ &= [x_0, x_1] \oplus [x_1, x_3] \oplus [x_3, x_2] \oplus [x_2, x_0] \end{aligned}$$

as intuition suggests.

2. Let  $R > 0$ , let

$$x_0 := \begin{bmatrix} R \\ 0 \end{bmatrix}, \quad x_1 := \begin{bmatrix} R \\ 2\pi \end{bmatrix}, \quad x_2 := \begin{bmatrix} 0 \\ 0 \end{bmatrix}, \quad x_3 := \begin{bmatrix} 0 \\ 2\pi \end{bmatrix},$$

so that  $\{[x_0, x_1, x_2] \oplus [x_1, x_3, x_2]\} = [0, R] \times [0, 2\pi]$  by the previous example. Let

$$T: \mathbb{R}^2 \rightarrow \mathbb{R}^2, \quad (\rho, \theta) \mapsto (\rho \cos \theta, \rho \sin \theta), \quad (7.7)$$

and set  $\Phi := T \circ [x_0, x_1, x_2] \oplus T \circ [x_1, x_3, x_2]$ , so that  $\{\Phi\} = B_R[(0, 0)]$ . It follows that

$$\partial\Phi = T \circ [x_0, x_1] \oplus T \circ [x_1, x_3] \oplus T \circ [x_3, x_2] \oplus T \circ [x_2, x_0]. \quad (7.8)$$

For  $t \in [0, 1]$  we have

$$\begin{aligned} (T \circ [x_0, x_1])(t) &= \begin{bmatrix} R \cos(2\pi t) \\ R \sin(2\pi t) \end{bmatrix}, \\ (T \circ [x_1, x_3])(t) &= \begin{bmatrix} (1-t)R \\ 0 \end{bmatrix}, \\ (T \circ [x_3, x_2])(t) &= \begin{bmatrix} 0 \\ 0 \end{bmatrix}, \\ (T \circ [x_2, x_0])(t) &= \begin{bmatrix} tR \\ 0 \end{bmatrix}. \end{aligned}$$

This means, in particular, that  $T \circ [x_2, x_0] = -T \circ [x_1, x_3]$ , so that  $\partial\Phi = T \circ [x_0, x_1]$ , i.e.,  $\partial B_R[(0, 0)]$  in counterclockwise orientation.

3. Let  $0 < r < R$ , let

$$x_0 := \begin{bmatrix} R \\ 0 \end{bmatrix}, \quad x_1 := \begin{bmatrix} R \\ 2\pi \end{bmatrix}, \quad x_2 := \begin{bmatrix} r \\ 0 \end{bmatrix}, \quad x_3 := \begin{bmatrix} r \\ 2\pi \end{bmatrix},$$

so that  $\{[x_0, x_1, x_2] \oplus [x_1, x_3, x_2]\} = [r, R] \times [0, 2\pi]$ . Let  $T$  be as in (7.7), so that  $\{\Phi\}$  is the annulus  $B_R((0, 0)) \setminus B_r((0, 0))$ . Then  $\partial\Phi$  is again given by (7.8). This time, however, for  $t \in [0, 1]$ ,

$$\begin{aligned} (T \circ [x_0, x_1])(t) &= \begin{bmatrix} R \cos(2\pi t) \\ R \sin(2\pi t) \end{bmatrix}, \\ (T \circ [x_1, x_3])(t) &= \begin{bmatrix} (1-t)R + tr \\ 0 \end{bmatrix}, \\ (T \circ [x_3, x_2])(t) &= \begin{bmatrix} r \cos(2\pi(1-t)) \\ r \sin(2\pi(1-t)) \end{bmatrix}, \\ (T \circ [x_2, x_0])(t) &= \begin{bmatrix} tR + (1-t)r \\ 0 \end{bmatrix}, \end{aligned}$$

so that

$$\partial\Phi = T \circ [x_0, x_1] \oplus T \circ [x_3, x_2],$$

i.e.,  $\partial B_R((0, 0)) \cup \partial B_r((0, 0))$  with “the outer boundary”  $\partial B_R((0, 0))$  oriented counterclockwise and “the inner boundary”  $\partial B_r((0, 0))$  oriented clockwise.

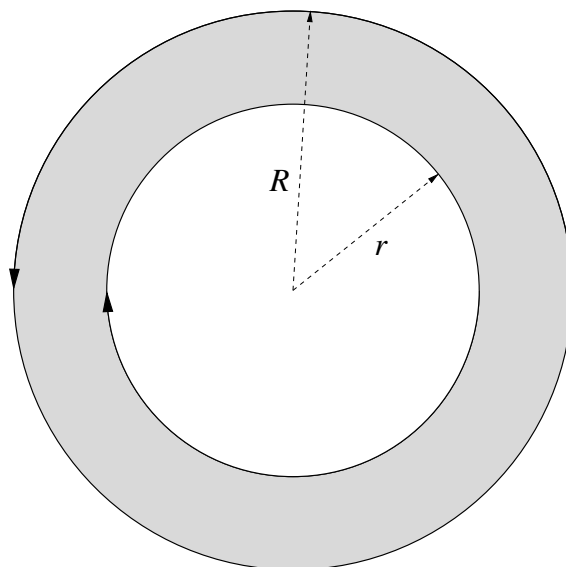

Figure 7.1: Oriented boundary of  $B_R((0, 0)) \setminus B_r((0, 0))$

**Proposition 7.4.12.** *Let  $r \in \mathbb{N}$ ,  $\Sigma = [x_0, x_1, \dots, x_r]$  be an oriented affine  $r$ -simplex,  $\sigma \in \mathfrak{S}_{r+1}$ , and set  $\Sigma_\sigma := [x_{\sigma(0)}, x_{\sigma(1)}, \dots, x_{\sigma(r)}]$ . Then, for any  $r$ -form  $\omega$  of class  $C^0$  on an open neighborhood of  $\{\Sigma\} = \{\Sigma_\sigma\}$ , we have*

$$\int_{\Sigma_\sigma} \omega = \operatorname{sgn} \sigma \int_{\Sigma} \omega. \quad (7.9)$$

*Proof.* We can suppose without loss of generality that

$$\omega = f dx_{j_1} \wedge \cdots \wedge dx_{j_r}$$

for a continuous function  $f: \{\Sigma\} \rightarrow \mathbb{R}$ . Furthermore, in view of Propositions 7.1.5 and 7.1.7(ii), it is enough to prove (7.9) in the case where  $\sigma$  is a transposition:

$$\int_{\Sigma_\sigma} \omega = - \int_{\Sigma} \omega. \quad (7.10)$$

*Case 1:*  $\sigma(0) = 0$ . For  $(t_1, \dots, t_r) \in \mathbb{R}^r$ , by definition

$$\Sigma(t_1, \dots, t_r) = \left( 1 - \sum_{j=1}^r t_j \right) x_0 + t_1 x_1 + \cdots + t_r x_r,$$

so that

$$\Sigma_\sigma(t_1, \dots, t_r) = \left( 1 - \sum_{j=1}^r t_j \right) x_0 + t_1 x_{\sigma(1)} + \cdots + t_r x_{\sigma(r)}.$$

Define

$$\Phi: \mathbb{R}^r \rightarrow \mathbb{R}^r, \quad (t_1, \dots, t_r) \mapsto (t_{\sigma(1)}, \dots, t_{\sigma(r)}),$$

so that

$$\Sigma_\sigma = \Sigma \circ \Phi, \quad \Sigma = \Sigma_\sigma \circ \Phi \quad \text{and} \quad \det J_\Phi = -1. \quad (7.11)$$

Let  $\Sigma_1, \dots, \Sigma_N$  denote the coordinate functions of  $\Sigma$  and  $\Sigma_{\sigma,1}, \dots, \Sigma_{\sigma,N}$  denote the coordinate functions of  $\Sigma_\sigma$ . From (7.6) we find

$$\omega_\Sigma = c(f \circ \Sigma) dt_1 \wedge \cdots \wedge dt_r$$

and

$$\omega_{\Sigma_\sigma} = -c(f \circ \Sigma_\sigma) dt_1 \wedge \cdots \wedge dt_r,$$

where

$$c = \begin{vmatrix} \frac{\partial \Sigma_{j_1}}{\partial t_1} & \cdots & \frac{\partial \Sigma_{j_1}}{\partial t_r} \\ \vdots & \ddots & \vdots \\ \frac{\partial \Sigma_{j_r}}{\partial t_1} & \cdots & \frac{\partial \Sigma_{j_r}}{\partial t_r} \end{vmatrix} = - \begin{vmatrix} \frac{\partial \Sigma_{\sigma, j_1}}{\partial t_1} & \cdots & \frac{\partial \Sigma_{\sigma, j_1}}{\partial t_r} \\ \vdots & \ddots & \vdots \\ \frac{\partial \Sigma_{\sigma, j_r}}{\partial t_1} & \cdots & \frac{\partial \Sigma_{\sigma, j_r}}{\partial t_r} \end{vmatrix}$$

is a real number that depends only on the given vertices of  $\Sigma$ .

Using theorem 7.3.5, we then conclude that

$$\begin{aligned}
 \int_{\Sigma} \omega &= \int_{\Sigma_{\sigma} \circ \Phi} \omega \\
 &= \int_{\Phi} \omega_{\Sigma_{\sigma}} \\
 &= - \int_{\Phi} \omega_{\Sigma} \\
 &= - \int_{\Sigma \circ \Phi} \omega \\
 &= - \int_{\Sigma_{\sigma}} \omega,
 \end{aligned}$$

which proves (7.10) in this case.

Case 2:  $\sigma(0) = 1$ .

Suppose first that  $\sigma(0) = 1$ . Define

$$\Phi: \mathbb{R}^r \rightarrow \mathbb{R}^r, \quad (t_1, \dots, t_r) \mapsto \left( 1 - \sum_{j=1}^r t_j, t_2, \dots, t_r \right).$$

Then  $\Phi$  also satisfies (7.11), and the same argument as in Case 1 proves (7.10).

Case 3:  $\sigma(0) > 1$ . Let  $k = \sigma(0)$  and  $\tau \in \mathfrak{S}_{r+1}$  be the permutation that interchanges  $k$  and 1. Then  $\tau \circ \sigma \circ \tau$  is a transposition that interchanges 0 and 1, so that (7.10) holds by Case 2 applied to  $\tau \circ \sigma \circ \tau$  in lieu of  $\sigma$ . On the other hand,  $\tau(0) = 0$ , so that Case 1 applies to  $\tau$  in lieu of  $\sigma$ . Note that

$$\int_{\Sigma_{\sigma}} \omega = \int_{\Sigma_{\tau \circ \sigma \circ \tau}} \omega = \int_{((\Sigma_{\tau})_{\tau \circ \sigma \circ \tau})_{\tau}} \omega = - \int_{(\Sigma_{\tau})_{\tau \circ \sigma \circ \tau}} \omega = \int_{\Sigma_{\tau}} \omega = - \int_{\Sigma} \omega,$$

so that (7.10) holds in this case too.  $\square$

In view of Lemma 7.3.5, we conclude:

**Corollary 7.4.13.** *Let  $r \in \mathbb{N}$ , let  $\Sigma = [x_0, x_1, \dots, x_r]$  be an oriented affine  $r$ -simplex, let  $\sigma \in \mathfrak{S}_{r+1}$ , and set  $\Sigma_{\sigma} := [x_{\sigma(0)}, x_{\sigma(1)}, \dots, x_{\sigma(r)}]$ . Then, for any map  $T$  of class  $\mathcal{C}^2$  defined on an open neighborhood of  $\{\Sigma\} = \{\Sigma_{\sigma}\}$ , and for any  $r$ -form  $\omega$  of class  $\mathcal{C}^0$  on an open neighborhood of  $\{T \circ \Sigma\} = \{T \circ \Sigma_{\sigma}\}$ , we have*

$$\int_{T \circ \Sigma_{\sigma}} \omega = \operatorname{sgn} \sigma \int_{T \circ \Sigma} \omega.$$

For  $r \in \mathbb{N}$ , the integral of an  $r$ -form over an oriented affine  $r$ -simplex follows from the definition of a surface integral, Definition 7.3.2. We now define the integral of a zero form on an oriented affine 0-simplex.

**Definition 7.4.14.** Let  $x_0 \in \mathbb{R}^N$ , and let  $f$  be a 0-form defined on an open neighborhood of  $x_0$ . Then

$$\int_{\pm[x_0]} f = \pm f(x_0).$$

We can now define the integral an  $r$ -form over an oriented  $r$ -chain.

**Definition 7.4.15.** Let  $r \in \mathbb{N}_0$ , and let  $\Phi := [\Phi_1] \oplus \cdots \oplus [\Phi_m]$  be an oriented  $r$ -chain in  $\mathbb{R}^N$ , and let  $\omega$  be an  $r$ -form of class  $\mathcal{C}^0$  on an open neighborhood of  $\{\Phi\}$ . Then

$$\int_{\Phi} \omega := \int_{\Phi_1} \omega + \cdots + \int_{\Phi_m} \omega.$$

### Exercises

1. Let  $r \in \mathbb{N}$ , and let  $(x_0, x_1, \dots, x_r) \in (\mathbb{R}^N)^r$ . Show that

$$\{[x_0, x_1, \dots, x_r]\} = \left\{ s_0 x_0 + s_1 x_1 + \cdots + s_r x_r : s_0, s_1, \dots, s_r \geq 0, \sum_{j=0}^r s_j = 1 \right\}.$$

2. Let  $r > 0$ , let

$$x_0 := \begin{bmatrix} 0 \\ 0 \end{bmatrix}, \quad x_1 := \begin{bmatrix} 2\pi \\ 0 \end{bmatrix}, \quad x_2 := \begin{bmatrix} 2\pi \\ \frac{\pi}{2} \end{bmatrix}, \quad \text{and} \quad x_3 := \begin{bmatrix} 0 \\ \frac{\pi}{2} \end{bmatrix},$$

let  $K$  be the rectangle in  $\mathbb{R}^2$  with the vertices  $x_0, x_1, x_2$ , and  $x_3$ , and let

$$\Phi: \mathbb{R}^2 \rightarrow \mathbb{R}^3, \quad (s, t) \mapsto r(\cos s)(\cos t) \mathbf{i} + r(\sin s)(\cos t) \mathbf{j} + r \sin t \mathbf{k}$$

be the surface in  $\mathbb{R}^3$  with parameter domain  $K$ . Set  $\Sigma_1 := [x_0, x_1, x_2]$  and  $\Sigma_2 := [x_0, x_2, x_3]$ , let  $\Phi_k := \Phi \circ \Sigma_k$  for  $k = 1, 2$ , and let  $\Psi := \Phi_1 \oplus \Phi_2$ . Determine  $\{\Psi\}$  in geometric terms.

## 7.5 Stokes' Theorem

**Lemma 7.5.1.** Let  $r \in \mathbb{N}$ , let  $\mathbf{e}_1, \dots, \mathbf{e}_r$  be the canonical unit vectors of  $\mathbb{R}^r$ , and let  $\Sigma := [0, \mathbf{e}_1, \dots, \mathbf{e}_r]$ . Then for any  $(r-1)$ -form of class  $\mathcal{C}^1$  defined on an open neighborhood of  $\{\Sigma\}$ , we have

$$\int_{\Sigma} d\omega = \int_{\partial\Sigma} \omega. \quad (7.12)$$

*Proof.* Set

$$\Sigma_0 := [\mathbf{e}_1, \dots, \mathbf{e}_r], \quad \Sigma_1 := [0, \mathbf{e}_2, \dots, \mathbf{e}_r], \quad \dots, \quad \Sigma_r := [0, \mathbf{e}_1, \dots, \mathbf{e}_{r-1}]$$

so that

$$\partial\Sigma = \bigoplus_{j=0}^r (-1)^j \Sigma_j.$$

First, consider the case where  $r = 1$ . In this case,  $\Sigma_1 = [0, 1]$ ,  $\partial\Sigma = [1] \oplus (-[0])$ , and  $\omega$  is a continuously differentiable function  $f$  defined on (a neighborhood of)  $[0, 1]$ . We obtain

$$\int_{\Sigma} d\omega = \int_0^1 f'(x) dx = f(1) - f(0) = \int_{\partial\Sigma} \omega.$$

Let now  $r \geq 2$ . Suppose without loss of generality that

$$\omega = f dx_2 \wedge \cdots \wedge dx_r,$$

with  $f$  being continuously differentiable on an open neighborhood of  $\Sigma_r$ . For an  $(r-1)$ -tuple  $(t_1, \dots, t_{r-1}) \in \Sigma_{r-1}$ , we have

$$\begin{aligned} \Sigma_0(t_1, \dots, t_{r-1}) &= \left( 1 - \sum_{j=1}^{r-1} t_j \right) \mathbf{e}_1 + t_1 \mathbf{e}_2 + \cdots + t_{r-1} \mathbf{e}_r, \\ \Sigma_1(t_1, \dots, t_{r-1}) &= t_1 \mathbf{e}_2 + t_2 \mathbf{e}_3 + \cdots + t_{r-1} \mathbf{e}_r, \\ \Sigma_2(t_1, \dots, t_{r-1}) &= t_1 \mathbf{e}_1 + t_2 \mathbf{e}_3 + \cdots + t_{r-1} \mathbf{e}_r, \end{aligned}$$

and

$$\Sigma_r(t_1, \dots, t_{r-1}) = t_1 \mathbf{e}_1 + t_2 \mathbf{e}_2 + \cdots + t_{r-1} \mathbf{e}_{r-1}.$$

For  $j = 0, 1, \dots, r$ , let  $\Sigma_j = (\Sigma_{j,1}, \dots, \Sigma_{j,r})$ . Then

$$\begin{vmatrix} \frac{\partial \Sigma_{0,2}}{\partial t_1}, & \cdots, & \frac{\partial \Sigma_{0,r}}{\partial t_1} \\ \vdots & \ddots & \vdots \\ \frac{\partial \Sigma_{0,2}}{\partial t_{r-1}}, & \cdots, & \frac{\partial \Sigma_{0,r}}{\partial t_{r-1}} \end{vmatrix} = \begin{vmatrix} \frac{\partial \Sigma_{1,2}}{\partial t_1}, & \cdots, & \frac{\partial \Sigma_{1,r}}{\partial t_1} \\ \vdots & \ddots & \vdots \\ \frac{\partial \Sigma_{1,2}}{\partial t_{r-1}}, & \cdots, & \frac{\partial \Sigma_{1,r}}{\partial t_{r-1}} \end{vmatrix} = 1$$

and for  $j = 2, \dots, r$ ,

$$\begin{vmatrix} \frac{\partial \Sigma_{j,2}}{\partial t_1}, & \cdots, & \frac{\partial \Sigma_{j,r}}{\partial t_1} \\ \vdots & \ddots & \vdots \\ \frac{\partial \Sigma_{j,2}}{\partial t_{r-1}}, & \cdots, & \frac{\partial \Sigma_{j,r}}{\partial t_{r-1}} \end{vmatrix} = 0.$$

It follows that

$$\begin{aligned} \int_{\partial\Sigma} \omega &= \int_{\Sigma_0} \omega - \int_{\Sigma_1} \omega \\ &= \int_{\Sigma_{r-1}} f \circ \Sigma_0 - f \circ \Sigma_1 \\ &= \int_{\substack{t_1, \dots, t_{r-1} \geq 0 \\ \sum_{j=1}^{r-1} t_j \leq 1}} (f(1 - t_1 - \cdots - t_{r-1}, t_1, \dots, t_{r-1}) - f(0, t_1, \dots, t_{r-1})) dt_1 \cdots dt_{r-1}. \end{aligned} \tag{7.13}$$

We now consider the left hand side of (7.12). We have

$$d\omega = \left( \frac{\partial f}{\partial x_1} dx_1 + \cdots + \frac{\partial f}{\partial x_r} dx_r \right) \wedge dx_2 \wedge \cdots \wedge dx_r = \frac{\partial f}{\partial x_1} dx_1 \wedge dx_2 \wedge \cdots \wedge dx_r$$

and therefore

$$\begin{aligned} \int_{\Sigma} d\omega &= \int_{\Sigma_r} \frac{\partial f(t_1, \dots, t_r)}{\partial x_1} dt_1 \cdots dt_r \\ &= \int_{\substack{t_2, \dots, t_r \geq 0 \\ \sum_{j=2}^r t_j \leq 1}} \left( \int_0^{1-t_2-\cdots-t_r} \frac{\partial f(t_1, \dots, t_r)}{\partial x_1} dt_1 \right) dt_2 \cdots dt_r \\ &= \int_{\substack{t_2, \dots, t_r \geq 0 \\ \sum_{j=2}^r t_j \leq 1}} (f(1-t_2-\cdots-t_r, t_2, \dots, t_r) - f(0, t_2, \dots, t_r)) dt_2 \cdots dt_r, \end{aligned}$$

which is equivalent to the right hand side of (7.13).  $\square$

**Theorem 7.5.2** (Stokes' Theorem for Differential Forms over  $r$ -Chains). *Let  $\Phi$  be an  $r$ -chain, and let  $\omega$  be an  $(r-1)$ -form of class  $\mathcal{C}^1$  on an open neighborhood of  $\{\Phi\}$ . Then*

$$\int_{\Phi} d\omega = \int_{\partial\Phi} \omega.$$

*Proof.* Without loss of generality suppose that  $\Phi$  is an oriented  $r$ -simplex. Let  $\Sigma$  be an oriented affine  $r$ -simplex, and let  $T$  be a map of class  $\mathcal{C}^2$  defined on an open neighborhood of  $\{\Sigma\}$ . We can suppose without loss of generality that  $\Sigma = [0, e_1, \dots, e_r]$ . We obtain

$$\begin{aligned} \int_{\Phi} d\omega &= \int_{T \circ \Sigma} d\omega \\ &= \int_{\Sigma} (d\omega)_T, && \text{by Theorem 7.3.5,} \\ &= \int_{\Sigma} d\omega_T, && \text{by Proposition 7.2.8(iii),} \\ &= \int_{\partial\Sigma} \omega_T, && \text{by Lemma 7.5.1,} \\ &= \int_{\partial\Phi} \omega, && \text{by Theorem 7.3.5 again,} \end{aligned}$$

which proves the theorem.  $\square$

We now look at Stokes' Theorem for particular values of  $N$  and  $r$ .

*Examples.*

1. Let  $N = 3$  and  $r = 1$ , with

$$\omega = P dx + Q dy + R dz.$$



It follows that

$$\begin{aligned} & \int_{\partial\Phi} P dx + Q dy + R dz \\ &= \int_{\partial\Phi} \omega \\ &= \int_{\Phi} d\omega \\ &= \int_{\Phi} \left( \frac{\partial R}{\partial y} - \frac{\partial Q}{\partial z} \right) dy \wedge dz + \left( \frac{\partial P}{\partial z} - \frac{\partial R}{\partial x} \right) dz \wedge dx + \left( \frac{\partial Q}{\partial x} - \frac{\partial P}{\partial y} \right) dx \wedge dy, \end{aligned}$$

which is Stokes' Theorem in its classical form.

2. Let  $N = 2$  and  $r = 1$ , with

$$\omega = P dx + Q dy,$$

and let  $\Phi$  be the identity map on  $\mathbb{R}^2$  with a suitable parameter domain  $K$ . We obtain

$$\int_{\partial\Phi} P dx + Q dy = \int_{\Phi} \left( \frac{\partial Q}{\partial x} - \frac{\partial P}{\partial y} \right) dx \wedge dy = \int_K \left( \frac{\partial Q}{\partial x} - \frac{\partial P}{\partial y} \right),$$

which is Green's Theorem.

3. Let  $N = 3$  and  $r = 2$ , with

$$\omega = P dy \wedge dz + Q dz \wedge dy + R dx \wedge dy$$

and

$$d\omega = \left( \frac{\partial P}{\partial x} + \frac{\partial Q}{\partial y} + \frac{\partial R}{\partial z} \right) dx \wedge dy \wedge dz,$$

and let  $\Phi$  be the identity on  $\mathbb{R}^3$  with a suitable parameter domain  $K$ . Letting  $f = P\mathbf{i} + Q\mathbf{j} + R\mathbf{k}$ , we obtain

$$\begin{aligned} \int_{\partial\Phi} f \cdot n d\sigma &= \int_{\partial\Phi} P dy \wedge dz + Q dz \wedge dy + R dx \wedge dy \\ &= \int_{\Phi} \left( \frac{\partial P}{\partial x} + \frac{\partial Q}{\partial y} + \frac{\partial R}{\partial z} \right) dx \wedge dy \wedge dz \end{aligned}$$

This is—in essence—Gauß' Theorem (see Exercise 1 on pg. 242).

4. Let  $N$  be arbitrary and let  $r = 0$ , with  $\Phi$  being a  $C^1$ -curve  $\gamma: [a, b] \rightarrow \mathbb{R}^N$ , which we can extend to a  $C^1$  function defined on an open set containing  $[a, b]$ . For a continuously partially differentiable function  $F$  defined on an open neighborhood of  $\{\gamma\}$ , we therefore obtain

$$\int_{\gamma} \nabla F \cdot dx = \int_{\Phi} \frac{\partial F}{\partial x_1} dx_1 + \cdots + \frac{\partial F}{\partial x_N} dx_N = \int_{\partial\Phi} F = F(\gamma(b)) - F(\gamma(a)),$$

recovering the Fundamental Theorem for Curve Integrals.

5. Let  $N = 1$  and  $r = 0$ , with  $\Phi = [a, b]$ . We obtain for for a  $C^1$ -function  $f: [a, b] \rightarrow \mathbb{R}$  that

$$\int_a^b f'(x) dx = \int_{\Phi} f'(x) dx = \int_{\partial\Phi} f = f(b) - f(a).$$

This is the Fundamental Theorem of Calculus.

## Exercises

1. Work out Example 3 in this section, i.e., derive (a reasonable version) of Gauß' Theorem from Stokes's Theorem for differential forms.

## Chapter 8

# Infinite Series and Improper Integrals

### 8.1 Infinite Series

Consider

$$\sum_{k=0}^{\infty} (-1)^k = \begin{cases} (1 - 1) + (1 - 1) + \cdots & = 0, \\ 1 + (-1 + 1) + (-1 + 1) + \cdots & = 1. \end{cases}$$

Which value is correct?

**Definition 8.1.1.** Let  $(a_k)_{k=1}^{\infty}$  be a sequence in  $\mathbb{R}$ . Then the sequence  $(s_n)_{n=1}^{\infty}$  with  $s_n := \sum_{k=1}^n a_k$  for  $n \in \mathbb{N}$  is called an (*infinite*) *series* and denoted by  $\sum_{k=1}^{\infty} a_k$ ; the terms  $s_n$  of that sequence are called the *partial sums* of  $\sum_{k=1}^{\infty} a_k$ . We say that the series  $\sum_{k=1}^{\infty} a_k$  converges if  $\lim_{n \rightarrow \infty} s_n$  exists; this limit is then also denoted by  $\sum_{k=1}^{\infty} a_k$ .

Hence, the symbol  $\sum_{k=1}^{\infty} a_k$  stands both for the sequence  $(s_n)_{n=1}^{\infty}$  as well as—if that sequence converges—for its limit.

Since infinite series are nothing but particular sequences, all we know about sequences can be applied to series. For example:

**Proposition 8.1.2.** Let  $\sum_{k=1}^{\infty} a_k$  and  $\sum_{k=1}^{\infty} b_k$  be convergent series, and let  $\alpha, \beta \in \mathbb{R}$ . Then  $\sum_{k=1}^{\infty} (\alpha a_k + \beta b_k)$  converges and satisfies

$$\sum_{k=1}^{\infty} (\alpha a_k + \beta b_k) = \alpha \sum_{k=1}^{\infty} a_k + \beta \sum_{k=1}^{\infty} b_k.$$

*Proof.* The limit laws yield

$$\begin{aligned} \alpha \sum_{k=1}^{\infty} a_k + \beta \sum_{k=1}^{\infty} b_k &= \alpha \lim_{n \rightarrow \infty} \sum_{k=1}^n a_k + \beta \lim_{n \rightarrow \infty} \sum_{k=1}^n b_k \\ &= \lim_{n \rightarrow \infty} \sum_{k=1}^n (\alpha a_k + \beta b_k) \\ &= \sum_{k=1}^{\infty} (\alpha a_k + \beta b_k). \end{aligned}$$

This proves the claim.  $\square$

Here are a few examples:

*Examples.*

1. The *Harmonic series*. For  $k \in \mathbb{N}$ , let  $a_k := \frac{1}{k}$ , so that

$$s_{2n} - s_n = \sum_{k=n+1}^{2n} \frac{1}{k} \geq \sum_{k=n+1}^{2n} \frac{1}{2n} = \frac{1}{2}.$$

Hence,  $(s_n)_{n=1}^{\infty}$  is not a Cauchy sequence, so that  $\sum_{k=1}^{\infty} \frac{1}{k}$  diverges.

2. *Geometric series*. Let  $r \neq 1$ , and let  $a_k := r^k$  for  $k \in \mathbb{N}_0$ . We obtain for  $n \in \mathbb{N}_0$  that

$$s_n - r s_n = \sum_{k=0}^n r^k - \sum_{k=0}^n r^{k+1} = \sum_{k=0}^n r^k - \sum_{k=1}^{n+1} r^k = 1 - r^{n+1},$$

i.e.,

$$(1 - r)s_n = 1 - r^{n+1}$$

and therefore

$$s_n = \frac{1 - r^{n+1}}{1 - r}.$$

Hence,  $\sum_{k=0}^{\infty} r^k$  diverges if  $|r| \geq 1$ , whereas  $\sum_{k=0}^{\infty} r^k = \frac{1}{1-r}$  if  $|r| < 1$ .

**Proposition 8.1.3.** *Let  $(a_k)_{k=1}^{\infty}$  be a sequence of non-negative reals. Then  $\sum_{k=1}^{\infty} a_k$  converges if and only if  $(s_n)_{n=1}^{\infty}$  is a bounded sequence.*

*Proof.* Since  $a_k \geq 0$  for  $k \in \mathbb{N}$ , we have  $s_{n+1} = s_n + a_{n+1} \geq s_n$ . It follows that  $(s_n)_{n=1}^{\infty}$  is an increasing sequence, which is convergent if and only if it is bounded.  $\square$

If  $(a_k)_{k=1}^{\infty}$  is a sequence of non-negative reals, we write  $\sum_{k=1}^{\infty} a_k < \infty$  if the series converges and  $\sum_{k=1}^{\infty} a_k = \infty$  otherwise.

*Examples.*

1. As we have just seen,  $\sum_{k=1}^{\infty} \frac{1}{k} = \infty$  holds.
2. We claim that  $\sum_{k=1}^{\infty} \frac{1}{k^2} < \infty$ . To see this, let  $a_k := \frac{1}{k(k+1)}$  for  $k \in \mathbb{N}$ , so that

$$a_k = \frac{1}{k} - \frac{1}{k+1}.$$

It follows that

$$\sum_{k=1}^n a_k = \sum_{k=1}^n \left( \frac{1}{k} - \frac{1}{k+1} \right) = 1 - \frac{1}{n+1} \rightarrow 1,$$

so that  $\sum_{k=1}^{\infty} a_k < \infty$ . Since

$$\sum_{k=1}^n \frac{1}{k^2} = 1 + \sum_{k=2}^n \frac{1}{k^2} \leq 1 + \sum_{k=2}^n \frac{1}{k(k-1)} = 1 + \sum_{k=1}^{n-1} a_k,$$

this means that  $\sum_{k=1}^{\infty} \frac{1}{k^2} < \infty$ .

The following is an immediate consequence of the Cauchy Criterion for convergent sequences:

**Theorem 8.1.4** (Cauchy Criterion). *The infinite series  $\sum_{k=1}^{\infty} a_k$  converges if, for each  $\epsilon > 0$ , there exists  $n_{\epsilon} \in \mathbb{N}$  such that, for all  $n, m \in \mathbb{N}$  with  $n > m \geq n_{\epsilon}$ , we have*

$$\left| \sum_{k=m+1}^n a_k \right| < \epsilon.$$

**Corollary 8.1.5.** *Suppose that the infinite series  $\sum_{k=1}^{\infty} a_k$  converges. Then  $\lim_{k \rightarrow \infty} a_k = 0$ .*

*Proof.* Let  $\epsilon > 0$ , and let  $n_{\epsilon} \in \mathbb{N}$  be as in the Cauchy Criterion. It follows that

$$|a_{n+1}| = \left| \sum_{k=n+1}^{n+1} a_k \right| < \epsilon$$

for all  $n \geq n_{\epsilon}$ . □

*Examples.*

1. The series  $\sum_{k=0}^{\infty} (-1)^k$  diverges.
2. The series  $\sum_{k=1}^{\infty} \frac{1}{k}$  also diverges even though  $\lim_{n \rightarrow \infty} \frac{1}{n} = 0$ .

**Definition 8.1.6.** A series  $\sum_{k=1}^{\infty} a_k$  is said to be *absolutely convergent* if  $\sum_{k=1}^{\infty} |a_k| < \infty$ .

*Example.* For  $r \in (-1, 1)$ , the geometric series  $\sum_{k=0}^{\infty} r^k$  converges absolutely.

**Proposition 8.1.7.** *Let  $\sum_{k=1}^{\infty} a_k$  be an absolutely convergent series. Then  $\sum_{k=1}^{\infty} a_k$  converges.*

*Proof.* Let  $\epsilon > 0$ . The Cauchy Criterion for  $\sum_{k=1}^{\infty} |a_k|$  yields  $n_\epsilon \in \mathbb{N}$  such that

$$\sum_{k=m+1}^n |a_k| < \epsilon$$

for  $n \geq m \geq n_\epsilon$ . Since

$$\left| \sum_{k=m+1}^n a_k \right| \leq \sum_{k=m+1}^n |a_k| < \epsilon$$

for  $n \geq m \geq n_\epsilon$ , the convergence of  $\sum_{k=1}^{\infty} a_k$  follows from the Cauchy Criterion (this time applied to  $\sum_{k=1}^{\infty} a_k$ ).  $\square$

*Remark.* The converse of Proposition 8.1.7 need not be true: the alternating harmonic series  $\sum_{k=1}^{\infty} \frac{(-1)^k}{k}$  is convergent but not absolutely convergent: the harmonic series  $\sum_{k=1}^{\infty} \frac{1}{k}$  diverges.

**Definition 8.1.8.** A series is *conditionally convergent* if it is convergent but not absolutely convergent.

The following *summation by parts* formula is useful for developing tests of conditional convergence.

**Lemma 8.1.9** (*Abel's Summation by Parts*).

$$\sum_{k=n}^m f_k(g_{k+1} - g_k) = f_{m+1}g_{m+1} - f_n g_n - \sum_{k=n}^m (f_{k+1} - f_k)g_{k+1}$$

*Proof.*

$$\begin{aligned} \sum_{k=n}^m f_k(g_{k+1} - g_k) &= \sum_{k=n}^m f_k g_{k+1} - \sum_{k=n}^m f_k g_k \\ &= \sum_{k=n}^m f_k g_{k+1} + f_{m+1}g_{m+1} - \sum_{k=n+1}^{m+1} f_k g_k - f_n g_n \\ &= f_{m+1}g_{m+1} - f_n g_n + \sum_{k=n}^m f_k g_{k+1} - \sum_{k=n}^m f_{k+1} g_{k+1} \\ &= f_{m+1}g_{m+1} - f_n g_n - \sum_{k=n}^m (f_{k+1} - f_k)g_{k+1}. \end{aligned}$$

$\square$

**Definition 8.1.10.** An *alternating series* is of the form

$$\sum_{k=1}^{\infty} (-1)^k a_k,$$

where  $a_k \geq 0$  for  $k \in \mathbb{N}$ .

**Definition 8.1.11.** A sequence  $(a_k)_{k=1}^{\infty}$  is of *bounded variation* if  $\sum_{k=1}^{\infty} |a_{k+1} - a_k|$  converges.

*Example.* A monotonic bounded sequence is always of bounded variation.

*Remark.* By Proposition 8.1.7, if a sequence  $(a_k)_{k=1}^{\infty}$  is of bounded variation, then  $\sum_{k=1}^{\infty} (a_{k+1} - a_k)$  converges. It follows that  $\lim_{n \rightarrow \infty} a_n = \lim_{n \rightarrow \infty} a_{n+1} = a_1 + \lim_{n \rightarrow \infty} \sum_{k=1}^n (a_{k+1} - a_k)$  exists.

**Theorem 8.1.12** (Dirichlet Test). *Let  $s_n = \sum_{k=1}^n b_k$ . Suppose*

(i)  $(s_n)_{n=1}^{\infty}$  *is a bounded sequence.*

(ii)  $\lim_{k \rightarrow \infty} a_k = 0$  *and  $(a_k)_{k=1}^{\infty}$  is of bounded variation.*

*Then  $\sum_{k=1}^{\infty} a_k b_k$  converges.*

*Proof:* We know from (i) that there exists a number  $B > 0$  such that  $|s_n| \leq B$  for all  $n \in \mathbb{N}$ . Given  $\epsilon > 0$ , we know from (ii) and the Cauchy Criterion that there exists  $N > 0$  such that

$$n > N \implies |a_n| < \frac{\epsilon}{3B}$$

and

$$m > n > N \implies \sum_{k=n}^m |a_{k+1} - a_k| < \frac{\epsilon}{3B}.$$

Using **Summation by Parts** we then find that

$$\begin{aligned} \left| \sum_{k=n}^m a_k b_k \right| &= \left| \sum_{k=n}^m a_k (s_k - s_{k-1}) \right| \\ &= \left| a_{m+1} s_m - a_n s_{n-1} - \sum_{k=n}^m (a_{k+1} - a_k) s_k \right| \\ &\leq |a_{m+1}| B + |a_n| B + B \sum_{k=n}^m |a_{k+1} - a_k| \\ &< \frac{\epsilon}{3} + \frac{\epsilon}{3} + \frac{\epsilon}{3} = \epsilon. \end{aligned}$$

On applying the Cauchy Criterion again, we see that  $\sum_{k=1}^{\infty} a_k b_k$  converges.

**Corollary 8.1.13** (Leibniz Alternating Series Test). *The alternating series  $\sum_{k=1}^{\infty} (-1)^k a_k$  is convergent if the sequence  $(a_k)_{k=1}^{\infty}$  decreases monotonically to 0.*

*Proof.* Apply the **Dirichlet Test** with  $b_k = (-1)^k$ , using the fact that the bounded monotone sequence  $a_k$  is of bounded variation.  $\square$

*Example.* The alternating harmonic series  $\sum_{k=1}^{\infty} \frac{(-1)^k}{k}$  is conditionally convergent.

**Proposition 8.1.14.** *Let  $\sum_{k=1}^{\infty} a_k$  and  $\sum_{k=1}^{\infty} b_k$  be absolutely convergent series, and let  $\alpha, \beta \in \mathbb{R}$ . Then  $\sum_{k=1}^{\infty} (\alpha a_k + \beta b_k)$  is also absolutely convergent.*

*Proof.* Since both  $\sum_{k=1}^{\infty} a_k$  and  $\sum_{k=1}^{\infty} b_k$  converge absolutely, we have for  $n \in \mathbb{N}$  that

$$\sum_{k=1}^n |\alpha a_k + \beta b_k| \leq |\alpha| \sum_{k=1}^n |a_k| + |\beta| \sum_{k=1}^n |b_k| \leq |\alpha| \sum_{k=1}^{\infty} |a_k| + |\beta| \sum_{k=1}^{\infty} |b_k|.$$

Hence, the increasing sequence  $(\sum_{k=1}^n |\alpha a_k + \beta b_k|)_{k=1}^{\infty}$  is bounded and therefore convergent.  $\square$

Is the converse also true?

**Theorem 8.1.15** (Comparison Test). *Let  $(a_k)_{k=1}^{\infty}$  and  $(b_k)_{k=1}^{\infty}$  be sequences in  $\mathbb{R}$  such that  $b_k \geq 0$  for all  $k \in \mathbb{N}$ .*

- (i) *Suppose that  $\sum_{k=1}^{\infty} b_k < \infty$  and that there exists  $k_0 \in \mathbb{N}$  such that  $|a_k| \leq b_k$  for  $k \geq k_0$ . Then  $\sum_{k=1}^{\infty} a_k$  converges absolutely.*
- (ii) *Suppose that  $\sum_{k=1}^{\infty} b_k = \infty$  and that there exists  $k_0 \in \mathbb{N}$  such that  $a_k \geq b_k$  for  $k \geq k_0$ . Then  $\sum_{k=1}^{\infty} a_k$  diverges.*

*Proof.* (i): Note that

$$\sum_{k=1}^n |a_k| = \sum_{k=1}^{k_0-1} |a_k| + \sum_{k=k_0}^n |a_k| \leq \sum_{k=1}^{k_0-1} |a_k| + \sum_{k=k_0}^n b_k \leq \sum_{k=1}^{k_0-1} |a_k| + \sum_{k=1}^{\infty} b_k.$$

Hence, the sequence  $(\sum_{k=1}^n |a_k|)_{k=1}^{\infty}$  is bounded, i.e.,  $\sum_{k=1}^{\infty} a_k$  converges absolutely.

(ii): Note that

$$\sum_{k=1}^n a_k = \sum_{k=1}^{k_0-1} a_k + \sum_{k=k_0}^n a_k \geq \sum_{k=1}^{k_0-1} a_k + \sum_{k=k_0}^n b_k.$$

Since  $\sum_{k=1}^{\infty} b_k = \infty$ , it follows that that  $(\sum_{k=1}^n a_k)_{k=1}^{\infty}$  is unbounded and thus divergent.  $\square$

*Examples.*

1. Let  $p \in \mathbb{R}$ . Then

$$\sum_{k=1}^{\infty} \frac{1}{k^p} \left\{ \begin{array}{l} \text{diverges if } p \leq 1, \\ \text{converges if } p \geq 2. \end{array} \right.$$



2. Since

$$\left| \frac{\sin(k^{2023})}{4k^2 + \cos(e^{k^{13}})} \right| \leq \frac{1}{3k^2}$$

for  $k \in \mathbb{N}$ , and since  $\sum_{k=1}^{\infty} \frac{1}{3k^2} < \infty$ , it follows that  $\sum_{k=1}^{\infty} \frac{\sin(k^{2023})}{4k^2 + \cos(e^{k^{13}})}$  converges absolutely.

**Corollary 8.1.16** (Limit Comparison Test). *Let  $(a_k)_{k=1}^{\infty}$  and  $(b_k)_{k=1}^{\infty}$  be sequences in  $\mathbb{R}$  such that  $b_k \geq 0$  for all  $k \in \mathbb{N}$ .*

- (i) *Suppose that  $\sum_{k=1}^{\infty} b_k < \infty$  and that  $\lim_{k \rightarrow \infty} \frac{|a_k|}{b_k}$  exists (and is finite). Then  $\sum_{k=1}^{\infty} a_k$  converges absolutely.*
- (ii) *Suppose that  $\sum_{k=1}^{\infty} b_k = \infty$  and that  $\lim_{k \rightarrow \infty} \frac{a_k}{b_k}$  exists and is positive (possibly infinite). Then  $\sum_{k=1}^{\infty} a_k$  diverges.*

*Proof.* (i): There exist  $C \geq 0$  and  $k_0 \in \mathbb{N}$  such that  $\frac{|a_k|}{b_k} \leq C$  for all  $k \geq k_0$ , i.e.,  $|a_k| \leq Cb_k$ . The claim then follows from the Comparison Test.

(ii): Let  $k_0 \in \mathbb{N}$  and  $\delta > 0$  be such that  $\frac{a_k}{b_k} > \delta$  for  $k \geq k_0$ , i.e.,  $a_k \geq \delta b_k$ . The claim follows again from the Comparison Test.  $\square$

*Examples.*

1. Let

$$a_k := \frac{4k+1}{6k^2+7k} \quad \text{and} \quad b_k := \frac{1}{k}$$

for  $k \in \mathbb{N}$ . Since

$$\frac{a_k}{b_k} = \frac{4k^2+k}{6k^2+7k} \rightarrow \frac{2}{3} > 0,$$

and since  $\sum_{k=1}^{\infty} \frac{1}{k} = \infty$ , it follows that  $\sum_{k=1}^{\infty} \frac{4k+1}{6k^2+7k}$  diverges.

2. Let

$$a_k := \frac{17k \cos(k)}{k^4 + 49k^2 - 16k + 7} \quad \text{and} \quad b_k := \frac{1}{k^2}$$

for  $k \in \mathbb{N}$ . Since

$$\frac{|a_k|}{b_k} = \frac{17k^3 |\cos(k)|}{k^4 + 49k^2 - 16k + 7} \rightarrow 0,$$

and since  $\sum_{k=1}^{\infty} \frac{1}{k^2} < \infty$ , it follows that  $\sum_{k=1}^{\infty} \frac{17k \cos(k)}{k^4 + 49k^2 - 16k + 7}$  converges absolutely.

**Theorem 8.1.17** (Ratio Test). *Let  $(a_k)_{k=1}^{\infty}$  be a sequence in  $\mathbb{R}$ .*

- (i) *Suppose that there exist  $k_0 \in \mathbb{N}$  and  $r \in (0, 1)$  such that  $a_k \neq 0$  and  $\frac{|a_{k+1}|}{|a_k|} \leq r$  for  $k \geq k_0$ . Then  $\sum_{k=1}^{\infty} a_k$  converges absolutely.*
- (ii) *Suppose that there exist  $k_0 \in \mathbb{N}$  and  $r \geq 1$  such that  $a_k \neq 0$  and  $\frac{|a_{k+1}|}{|a_k|} \geq r$  for  $k \geq k_0$ . Then  $\sum_{k=1}^{\infty} a_k$  diverges.*

*Proof.* (i): Since  $|a_{k+1}| \leq |a_k|r$  for  $k \geq k_0$ , it follows by induction that

$$|a_k| \leq r^{k-k_0}|a_{k_0}|$$

for those  $k$ . Since  $r \in (0, 1)$ , the series  $\sum_{k=k_0}^{\infty} |a_{k_0}|r^{k-k_0}$  converges. The Comparison Test yields the convergence of  $\sum_{k=k_0}^{\infty} |a_k|$  and thus of  $\sum_{k=1}^{\infty} |a_k|$ .

(ii): Since  $|a_{k+1}| \geq r|a_k|$  for  $k \geq k_0$ , it follows by induction that

$$|a_k| \geq r^{k-k_0}|a_{k_0}| \geq |a_{k_0}| > 0$$

for those  $k$ . Consequently,  $(a_k)_{k=1}^{\infty}$  does not converge to zero, so that  $\sum_{k=1}^{\infty} a_k$  diverges.  $\square$

**Corollary 8.1.18** (Limit Ratio Test). *Let  $(a_k)_{k=1}^{\infty}$  be a sequence in  $\mathbb{R}$  such that  $a_k \neq 0$  for all but finitely many  $k \in \mathbb{N}$ .*

(i) *Then  $\sum_{k=1}^{\infty} a_k$  converges absolutely if  $\lim_{k \rightarrow \infty} \frac{|a_{k+1}|}{|a_k|} < 1$ .*

(ii) *Then  $\sum_{k=1}^{\infty} a_k$  diverges if  $\lim_{k \rightarrow \infty} \frac{|a_{k+1}|}{|a_k|} > 1$ .*

*Example.* Let  $x \in \mathbb{R} \setminus \{0\}$ , and let  $a_k := \frac{x^k}{k!}$  for  $k \in \mathbb{N}$ . It follows that

$$\frac{a_{k+1}}{a_k} = \frac{x^{k+1}}{(k+1)!} \frac{k!}{x^k} = \frac{x}{k} \rightarrow 0.$$

Consequently,  $\sum_{k=0}^{\infty} \frac{x^k}{k!}$  converges absolutely for all  $x \in \mathbb{R}$ .

If  $\lim_{k \rightarrow \infty} \frac{|a_{k+1}|}{|a_k|} = 1$ , *nothing* can be said about the convergence of  $\sum_{k=1}^{\infty} a_k$ :

- if  $a_k := \frac{1}{k}$  for  $k \in \mathbb{N}$ , then

$$\frac{a_{k+1}}{a_k} = \frac{k}{k+1} \rightarrow 1,$$

and  $\sum_{k=1}^{\infty} \frac{1}{k}$  diverges;

- if  $a_k := \frac{1}{k^2}$  for  $k \in \mathbb{N}$ , then

$$\frac{a_{k+1}}{a_k} = \frac{k^2}{(k+1)^2} \rightarrow 1,$$

and  $\sum_{k=1}^{\infty} \frac{1}{k^2}$  converges.

**Theorem 8.1.19** (Root Test). *Let  $(a_k)_{k=1}^{\infty}$  be a sequence in  $\mathbb{R}$ .*

(i) *Suppose that there exist  $k_0 \in \mathbb{N}$  and  $r \in (0, 1)$  such that  $\sqrt[k]{|a_k|} \leq r$  for  $k \geq k_0$ . Then  $\sum_{k=1}^{\infty} a_k$  converges absolutely.*

(ii) Suppose that there exist  $k_0 \in \mathbb{N}$  and  $r \geq 1$  such that  $\sqrt[k]{|a_k|} \geq r$  for  $k \geq k_0$ . Then  $\sum_{k=1}^{\infty} a_k$  diverges.

*Proof.* (i): This follows immediately from the Comparison Test because  $|a_k| \leq r^k$  for  $k \geq k_0$ .

(ii): This is also clear because  $|a_k| \geq r^k$  for  $k \geq k_0$ , so that  $a_k \not\rightarrow 0$ .  $\square$

**Corollary 8.1.20** (Limit Root Test). *Let  $(a_k)_{k=1}^{\infty}$  be a sequence in  $\mathbb{R}$ .*

(i) *Then  $\sum_{k=1}^{\infty} a_k$  converges absolutely if  $\lim_{k \rightarrow \infty} \sqrt[k]{|a_k|} < 1$ .*

(ii) *Then  $\sum_{k=1}^{\infty} a_k$  diverges if  $\lim_{k \rightarrow \infty} \sqrt[k]{|a_k|} > 1$ .*

*Example.* For  $k \in \mathbb{N}$ , let

$$a_k := \frac{2 + (-1)^k}{2^{k-1}}.$$

It follows that

$$\frac{a_{k+1}}{a_k} = \frac{2 + (-1)^{k+1}}{2^k} \frac{2^{k-1}}{2 + (-1)^k} = \frac{1}{2} \frac{2 - (-1)^k}{2 + (-1)^k} = \begin{cases} \frac{1}{6}, & \text{if } k \text{ is even,} \\ \frac{3}{2}, & \text{if } k \text{ is odd.} \end{cases}$$

Hence, the Ratio Test is inconclusive. However, we have

$$\sqrt[k]{|a_k|} = \sqrt[k]{\frac{2(2 + (-1)^k)}{2^k}} \leq \frac{\sqrt[k]{6}}{2} \rightarrow \frac{1}{2}.$$

Hence, there exists  $k_0 \in \mathbb{N}$  such that  $\sqrt[k]{|a_k|} < \frac{2}{3}$  for  $k \geq k_0$ . Hence,  $\sum_{k=1}^{\infty} \frac{2+(-1)^k}{2^{k-1}}$  converges absolutely by the Root Test.

**Theorem 8.1.21.** *Let  $\sum_{k=1}^{\infty} a_k$  be absolutely convergent. Then  $\sum_{k=1}^{\infty} a_{\sigma(k)}$  converges absolutely for each bijective  $\sigma: \mathbb{N} \rightarrow \mathbb{N}$  such that  $\sum_{k=1}^{\infty} a_k = \sum_{k=1}^{\infty} a_{\sigma(k)}$ .*

*Proof.* Let  $\epsilon > 0$ , and choose  $n_0 \in \mathbb{N}$  such that  $\sum_{k=n_0}^{\infty} |a_k| < \frac{\epsilon}{2}$ . Set  $x := \sum_{k=1}^{\infty} a_k$ . It follows that

$$\left| x - \sum_{k=1}^{n_0-1} a_k \right| = \left| \sum_{k=n_0}^{\infty} a_k \right| \leq \sum_{k=n_0}^{\infty} |a_k| < \frac{\epsilon}{2}.$$

Let  $\sigma: \mathbb{N} \rightarrow \mathbb{N}$  be bijective. Choose  $n_{\epsilon} \in \mathbb{N}$  large enough so that  $\{1, \dots, n_0 - 1\} \subset \{\sigma(1), \dots, \sigma(n_{\epsilon})\}$ . For  $m \geq n_{\epsilon}$ , we then have

$$\left| \sum_{k=1}^m a_{\sigma(k)} - x \right| \leq \left| \sum_{k=1}^m a_{\sigma(k)} - \sum_{k=1}^{n_0-1} a_k \right| + \left| \sum_{k=1}^{n_0-1} a_k - x \right| \leq \sum_{k=n_0}^{\infty} |a_k| + \frac{\epsilon}{2} < \epsilon.$$

Consequently,  $\sum_{k=1}^{\infty} a_{\sigma(k)}$  converges to  $x$  as well. The same argument, applied to the series  $\sum_{k=1}^{\infty} |a_k|$ , yields the absolute convergence of  $\sum_{k=1}^{\infty} a_{\sigma(k)}$ .  $\square$

**Theorem 8.1.22** (Riemann's Rearrangement Theorem). *Let  $\sum_{k=1}^{\infty} a_k$  be convergent, but not absolutely convergent, and let  $x \in \mathbb{R}$ . Then there exists a bijective map  $\sigma : \mathbb{N} \rightarrow \mathbb{N}$  such that  $\sum_{k=1}^{\infty} a_{\sigma(k)} = x$ .*

*Proof.* We seek a rearrangement of  $a_1, a_2, a_3, \dots$  such that the rearranged series converges to  $x$ .

Let  $b_1, b_2, b_3, \dots$  denote the non-negative terms of  $(a_k)_{k=1}^{\infty}$ , and let  $c_1, c_2, c_3, \dots$  be the negative ones. We claim that  $\sum_{k=1}^{\infty} b_k = \infty$ . Otherwise,

$$\sum_{k=1}^{\infty} c_k = \sum_{k=1}^{\infty} a_k - \sum_{k=1}^{\infty} b_k$$

would converge as would, consequently,

$$\sum_{k=1}^{\infty} |a_k| = \sum_{k=1}^{\infty} b_k - \sum_{k=1}^{\infty} c_k.$$

This would contradict the hypothesis that  $\sum_{k=1}^{\infty} a_k$  does not converge absolutely. Similarly, one sees that  $\sum_{k=1}^{\infty} c_k = -\infty$ .

Choose  $n_1 \in \mathbb{N}$  *minimal* such that

$$\sum_{k=1}^{n_1} b_k > x.$$

Then choose  $m_1 \in \mathbb{N}$  *minimal* such that

$$\sum_{k=1}^{n_1} b_k + \sum_{k=1}^{m_1} c_k < x.$$

Now choose  $n_2 \in \mathbb{N}$ ,  $n_2 > n_1$  *minimal* such that

$$\sum_{k=1}^{n_1} b_k + \sum_{k=1}^{m_1} c_k + \sum_{k=n_1+1}^{n_2} b_k > x.$$

Then choose  $m_2 \in \mathbb{N}$ ,  $m_2 > m_1$  *minimal* such that

$$\sum_{k=1}^{n_1} b_k + \sum_{k=1}^{m_1} c_k + \sum_{k=n_1+1}^{n_2} b_k + \sum_{k=m_1+1}^{m_2} c_k < x.$$

Continuing in this fashion, we obtain a rearrangement

$$b_1, \dots, b_{n_1}, c_1, \dots, c_{m_1}, b_{n_1+1}, \dots, b_{n_2}, c_{m_1+1}, \dots, c_{m_2}, b_{n_2+1}, \dots, b_{n_3}, c_{m_2+1}, \dots$$

of  $a_1, a_2, a_3, \dots$

For  $N \in \mathbb{N}$ , let  $s_N$  denote the  $N^{\text{th}}$  partial sum of the rearranged series. Then  $s_N$  is of one of the following forms for some  $\nu \in \mathbb{N}$ :

$$\sum_{k=1}^{n_1} b_k + \sum_{k=1}^{m_1} c_k + \cdots + \sum_{k=n_\nu+1}^n b_k \quad (8.1)$$

with  $n \leq n_{\nu+1}$  or

$$\sum_{k=1}^{n_1} b_k + \sum_{k=1}^{m_1} c_k + \cdots + \sum_{k=n_\nu+1}^{n_{\nu+1}} b_k + \sum_{k=m_\nu+1}^m c_k \quad (8.2)$$

with  $m \leq m_{\nu+1}$ .

Suppose that  $s_N$  is of the form (8.1). Then the minimality of  $n_{\nu+1}$  yields

$$|x - s_N| \leq b_{n_{\nu+1}}$$

if  $n = n_{\nu+1}$  and

$$|x - s_N| \leq -c_{m_\nu}$$

if  $n < n_{\nu+1}$ . Similarly, if  $s_N$  is of the form (8.2), we see that

$$|x - s_N| \leq -c_{m_{\nu+1}}$$

if  $m = m_{\nu+1}$  and

$$|x - s_N| \leq b_{n_\nu}$$

if  $m < m_{\nu+1}$ . Thus

$$|x - s_N| \leq \max\{b_{n_{\nu+1}}, -c_{m_\nu}, -c_{m_{\nu+1}}, b_{n_\nu}\}.$$

Since  $\sum_{k=1}^{\infty} a_k$  converges,  $\lim_{k \rightarrow \infty} a_k = 0$  and therefore  $\lim_{k \rightarrow \infty} b_k = \lim_{k \rightarrow \infty} c_k = 0$  as well. It follows that  $x = \lim_{N \rightarrow \infty} s_N$ .  $\square$

*Remark.* We can choose  $\sigma$  such that  $\sum_{k=1}^{\infty} a_{\sigma(k)} = \infty$  as well. To see this pick  $n_1 \in \mathbb{N}$  such that

$$\sum_{k=1}^{n_1} b_k > 1.$$

Then pick  $n_2 > n_1$  such that

$$\sum_{k=1}^{n_1} b_k + c_1 + \sum_{k=n_1+1}^{n_2} b_k > 2,$$

then  $n_3 > n_2$  such that

$$\sum_{k=1}^{n_1} b_k + c_1 + \sum_{k=n_1+1}^{n_2} b_k + c_2 + \sum_{k=n_2+1}^{n_3} b_k > 3,$$

and so on. This way, we obtain a rearrangement

$$b_1, \dots, b_{n_1}, c_1, b_{n_1+1}, \dots, b_{n_2}, c_2, b_{n_2+1}, \dots, b_{n_3}, c_3, \dots$$

of  $a_1, a_2, a_3, \dots$  such that the rearranged series tends to  $\infty$ . Similarly, we can choose  $\sigma$  such that  $\sum_{k=1}^{\infty} a_{\sigma(k)} = -\infty$ .

**Theorem 8.1.23** (Cauchy Product Formula). *Suppose that  $\sum_{k=0}^{\infty} a_k$  and  $\sum_{k=0}^{\infty} b_k$  converge*

*absolutely. Then  $\sum_{n=0}^{\infty} \sum_{k=0}^n a_k b_{n-k}$  converges absolutely such that*

$$\sum_{n=0}^{\infty} \sum_{k=0}^n a_k b_{n-k} = \left( \sum_{k=0}^{\infty} a_k \right) \left( \sum_{k=0}^{\infty} b_k \right).$$

*Proof.* For notational simplicity, let

$$c_n := \sum_{k=0}^n a_k b_{n-k} \quad \text{and} \quad C_m := \sum_{n=0}^m c_n$$

for  $n \in \mathbb{N}_0$ ; moreover, define

$$A := \sum_{k=0}^{\infty} a_k \quad \text{and} \quad B := \sum_{k=0}^{\infty} b_k.$$

We first claim that  $\lim_{m \rightarrow \infty} C_m = AB$ . To see this, define for  $n \in \mathbb{N}_0$ ,

$$D_m := \left( \sum_{k=0}^m a_k \right) \left( \sum_{k=0}^m b_k \right),$$

so that  $\lim_{m \rightarrow \infty} D_m = AB$ . It is therefore sufficient to show that  $\lim_{m \rightarrow \infty} (D_m - C_m) = 0$ . First note for  $m \in \mathbb{N}_0$  that

$$C_m = \sum_{n=0}^m \sum_{k=0}^n a_k b_{n-k} = \sum_{\substack{0 \leq k, j \\ k+j \leq m}} a_k b_j$$

and

$$D_m = \sum_{0 \leq k, j \leq m} a_k b_j,$$

so that

$$D_m - C_m = \sum_{\substack{0 \leq k, j \leq m \\ k+j > m}} a_k b_j.$$

For  $m \in \mathbb{N}_0$ , let

$$P_m := \left( \sum_{k=0}^m |a_k| \right) \left( \sum_{k=0}^m |b_k| \right) = \sum_{0 \leq k, j \leq m} |a_k b_j|.$$

The absolute convergence of  $\sum_{k=0}^{\infty} a_k$  and  $\sum_{k=0}^{\infty} b_k$  yields the convergence of  $(P_m)_{m=0}^{\infty}$ . Let  $\epsilon > 0$ , and choose  $m_\epsilon \in \mathbb{N}$  such that  $|P_m - P_{m_\epsilon}| < \epsilon$  for  $m \geq m_\epsilon$ . Let  $m \geq 2m_\epsilon$ ; it follows that

$$\begin{aligned} |D_m - C_m| &\leq \sum_{\substack{0 \leq k, j \leq m \\ k+j > m}} |a_k b_j| \\ &\leq \sum_{\substack{0 \leq k, j \leq m \\ k+j > 2m_\epsilon}} |a_k b_j| \\ &\leq \sum_{\substack{0 \leq k, j \leq m \\ k > m_\epsilon \text{ or } j > m_\epsilon}} |a_k b_j| \\ &= \sum_{0 \leq k, j \leq m} |a_k b_j| - \sum_{\substack{0 \leq k, j \leq m \\ k \leq m_\epsilon \text{ and } j \leq m_\epsilon}} |a_k b_j| \\ &= P_m - P_{m_\epsilon} \\ &< \epsilon. \end{aligned}$$

Hence, we obtain  $\lim_{m \rightarrow \infty} (D_m - C_m) = 0$ .

To show that  $\sum_{n=0}^{\infty} |c_n| < \infty$ , let  $\tilde{c}_n := \sum_{k=0}^n |a_k b_{n-k}|$ . An argument analogous to the first part of the proof yields the convergence of  $\sum_{n=0}^{\infty} \tilde{c}_n$ . The absolute convergence of  $\sum_{n=0}^{\infty} c_n$  then follows from the Comparison Test, noting from the triangle inequality that  $|c_n| \leq \tilde{c}_n$ .  $\square$

*Example.* For  $x \in \mathbb{R}$ , define

$$\exp(x) := \sum_{n=0}^{\infty} \frac{x^n}{n!};$$

we know that  $\exp(x)$  converges absolutely for all  $x \in \mathbb{R}$ . Let  $x, y \in \mathbb{R}$ . From the Cauchy Product Formula we obtain

$$\begin{aligned} \exp(x) \exp(y) &= \sum_{n=0}^{\infty} \sum_{k=0}^n \frac{x^k}{k!} \frac{y^{n-k}}{(n-k)!} \\ &= \sum_{n=0}^{\infty} \frac{1}{n!} \sum_{k=0}^n \frac{n!}{k!(n-k)!} x^k y^{n-k} \\ &= \sum_{n=0}^{\infty} \frac{1}{n!} \sum_{k=0}^n \binom{n}{k} x^k y^{n-k} \\ &= \sum_{n=0}^{\infty} \frac{(x+y)^n}{n!} \\ &= \exp(x+y). \end{aligned}$$

This identity has important consequences.

For instance, since

$$1 = \exp(0) = \exp(x - x) = \exp(x) \exp(-x)$$

for all  $x \in \mathbb{R}$ , it follows that  $\exp(x) \neq 0$  for all  $x \in \mathbb{R}$ , with  $\exp(x)^{-1} = \exp(-x)$ . Moreover, we have

$$\exp(x) = \exp\left(\frac{x}{2} + \frac{x}{2}\right) = \exp\left(\frac{x}{2}\right)^2 > 0$$

for all  $x \in \mathbb{R}$ . Induction on  $n$  shows that

$$\exp(n) = \exp(1)^n$$

for all  $n \in \mathbb{N}_0$ . It follows that

$$\exp(q) = \exp(1)^q$$

for all  $q \in \mathbb{Q}$ .

### Exercises

- Determine whether or not each of the following series converges or converges absolutely.

(a)  $\sum_{k=1}^{\infty} \frac{1}{\pi + \cos k}$ ;

(b)  $\sum_{k=1}^{\infty} \frac{\cos(\pi k)}{\sqrt{k+4}}$ ;

(c)  $\sum_{k=1}^{\infty} \frac{(-1)^k (k+1)}{k^3}$ .

- Let  $(a_k)_{k=1}^{\infty}$  be a decreasing sequence of non-negative real numbers. Show that  $\sum_{k=1}^{\infty} a_k$  converges if and only if  $\sum_{k=1}^{\infty} 2^k a_{2^k}$  converges.

What can you conclude about the convergence of  $\sum_{k=1}^{\infty} \frac{1}{k^p}$  for  $k \in \mathbb{R}$ ?

- Prove or give a counterexample to the following generalization of the Alternating Series Test:

Let  $(a_k)_{k=1}^{\infty}$  be a sequence of non-negative reals such that  $\lim_{k \rightarrow \infty} a_k = 0$ .

Then  $\sum_{k=1}^{\infty} (-1)^k a_k$  converges.

(Hint: Try  $a_k := \left| \frac{1}{k} - \frac{(-1)^k}{\sqrt{k}} \right|$ .)

- Test the following series for convergence and absolute convergence:

(a)  $\sum_{n=1}^{\infty} \binom{2n}{n}^{-1}$ ;



- (b)  $\sum_{\nu=42}^{\infty} \frac{7\nu^2 \cos(2023\nu^7)}{\sqrt{\nu(\nu^4-1)}}$ ;
- (c)  $\sum_{k=4}^{\infty} \frac{(-1)^{k^3}}{\log(\sqrt{k}+\log k)}$ ;
- (d)  $\sum_{m=2}^{\infty} \frac{1}{(\log m)^p}$  where  $p > 0$ .
5. Let  $(a_k)_{k=1}^{\infty}$  be a decreasing sequence of non-negative real numbers. Show with the help of the Cauchy Criterion for infinite series that  $\lim_{k \rightarrow \infty} ka_k = 0$  if  $\sum_{k=1}^{\infty} a_k$  converges. Does the converse also hold?
6. Let  $p$  be a polynomial, and let  $r \in (-1, 1)$ . Show that the series  $\sum_{k=1}^{\infty} p(k)r^k$  converges absolutely.
7. Let  $\sum_{k=1}^{\infty} a_k$  be an absolutely convergent series, and let  $(\lambda_k)_{k=1}^{\infty}$  be a bounded sequence in  $\mathbb{R}$ . Show that  $\sum_{k=1}^{\infty} \lambda_k a_k$  is absolutely convergent as well.  
If  $\sum_{k=1}^{\infty} a_k$  is merely supposed to converge, does then  $\sum_{k=1}^{\infty} \lambda_k a_k$  necessarily converge as well?
8. Let  $p$  and  $q$  be polynomials, let  $\nu$  be the degree of  $p$ , and let  $\mu$  be the degree of  $q$ . Suppose that  $k_0$  is such that  $q(k) \neq 0$  for all  $k \geq k_0$ . Show that the series  $\sum_{k=k_0}^{\infty} \frac{p(k)}{q(k)}$  converges if and only if  $\mu - \nu \geq 2$ .
9. For  $k \in \mathbb{N}_0$  let  $a_k := b_k := \frac{(-1)^k}{\sqrt{k+1}}$  and

$$c_n := \sum_{k=0}^n a_{n-k} b_k.$$

Show that  $\sum_{k=0}^{\infty} a_k$  and  $\sum_{k=0}^{\infty} b_k$  converge whereas  $\sum_{k=0}^{\infty} c_k$  diverges.

10. The number  $e$  is defined as  $e := \lim_{n \rightarrow \infty} \left(1 + \frac{1}{n}\right)^n$ . In this problem, you are asked to identify  $e$  as  $\exp(1)$  as defined in class. Proceed as follows:

- (a) Show that

$$\left(1 + \frac{1}{n}\right)^n \leq \sum_{k=0}^n \frac{1}{k!}$$

for  $n \in \mathbb{N}$ .

- (b) Show that

$$\begin{aligned} & \left(1 + \frac{1}{m}\right)^m \\ & \geq 1 + 1 + \left(1 - \frac{1}{m}\right) \frac{1}{2!} + \cdots + \left(1 - \frac{1}{m}\right) \left(1 - \frac{2}{m}\right) \cdots \left(1 - \frac{n-1}{m}\right) \frac{1}{n!} \end{aligned}$$

for all  $n, m \in \mathbb{N}$  with  $m > n$ .

- (c) Conclude from (a) and (b) that  $e = \sum_{n=0}^{\infty} \frac{1}{n!}$ .

## 8.2 Improper Riemann Integrals

What is

$$\int_0^1 \frac{1}{\sqrt{x}} dx?$$

Since  $\frac{d}{dx} 2\sqrt{x} = \frac{1}{\sqrt{x}}$ , it is tempting to argue that

$$\int_0^1 \frac{1}{\sqrt{x}} dx = 2\sqrt{x} \Big|_0^1 = 2.$$

However:

- $\frac{1}{\sqrt{x}}$  is not defined at 0;
- $\frac{1}{\sqrt{x}}$  is unbounded on  $(0, 1]$  and thus cannot be extended to  $[0, 1]$  as a Riemann-integrable function.

Hence, the fundamental theorem of calculus is not applicable.

What can be done?

Let  $\epsilon \in (0, 1]$ . Since  $\frac{1}{\sqrt{x}}$  is continuous on  $[\epsilon, 1]$ , the Fundamental Theorem yields (correctly) that

$$\int_{\epsilon}^1 \frac{1}{\sqrt{x}} dx = 2\sqrt{x} \Big|_{\epsilon}^1 = 2(1 - \sqrt{\epsilon}).$$

It therefore makes sense to *define*

$$\int_0^1 \frac{1}{\sqrt{x}} dx := \lim_{\epsilon \downarrow 0} \int_{\epsilon}^1 \frac{1}{\sqrt{x}} dx = 2.$$

### Definition 8.2.1.

- (a) Let  $a \in \mathbb{R}$ , let  $b \in \mathbb{R} \cup \{\infty\}$  such that  $a < b$ , and suppose that  $f : [a, b) \rightarrow \mathbb{R}$  is Riemann integrable on  $[a, c]$  for each  $c \in [a, b)$ . Then the *improper Riemann integral* of  $f$  over  $[a, b)$  is defined as

$$\int_a^b f(x) dx := \lim_{c \uparrow b} \int_a^c f(x) dx$$

if the limit exists.

- (b) Let  $a \in \mathbb{R} \cup \{-\infty\}$ , let  $b \in \mathbb{R}$  such that  $a < b$ , and suppose that  $f : (a, b] \rightarrow \mathbb{R}$  is Riemann integrable on  $[c, b]$  for each  $c \in (a, b]$ . Then the *improper Riemann integral* of  $f$  over  $(a, b]$  is defined as

$$\int_a^b f(x) dx := \lim_{c \downarrow a} \int_c^b f(x) dx$$

if the limit exists.

- (c) Let  $a \in \mathbb{R} \cup \{-\infty\}$ , let  $b \in \mathbb{R} \cup \{\infty\}$  such that  $a < b$ , and suppose that  $f: (a, b) \rightarrow \mathbb{R}$  is Riemann integrable on  $[c, d]$  for each  $c, d \in (a, b)$  with  $c < d$ . Then the *improper Riemann integral* of  $f$  over  $[a, b]$  is defined as

$$\int_a^b f(x) dx := \int_a^c f(x) dx + \int_c^b f(x) dx \quad (8.3)$$

with  $c \in (a, b)$  if the integrals on the right hand side of (8.3) both exist in the sense of (a) and (b).

*Remarks.* 1. Suppose that  $f: [a, b] \rightarrow \mathbb{R}$  is Riemann integrable. Then the original meaning of  $\int_a^b f(x) dx$  and the one from Definition 8.2.1 coincide (see Exercise 3 on pg. 265).

2. When any of the three different situations in Definition 8.2.1 overlap, the resulting improper integrals coincide.
3. The definition of  $\int_a^b f(x) dx$  in Definition 8.2.1(c) is independent of the choice of  $c \in (a, b)$ .

4. Since  $\int_{-R}^R \sin(x) dx = 0$  for all  $R > 0$ ,  $\lim_{R \rightarrow \infty} \int_{-R}^R \sin(x) dx$  exists (and equals zero). However, since the limit of

$$\int_0^R \sin(x) dx = -\cos(x)|_0^R = -\cos(R) + 1$$

does not exist for  $R \rightarrow \infty$ , the improper integral  $\int_{-\infty}^{\infty} \sin(x) dx$  does *not* exist.

In the following, we will focus on the case covered by Definition 8.2.1(a): The other cases can be treated analogously.

As for infinite series, there is a Cauchy Criterion for improper integrals:

**Theorem 8.2.2** (Cauchy Criterion). *Let  $a \in \mathbb{R}$ , let  $b \in \mathbb{R} \cup \{\infty\}$  such that  $a < b$ , and suppose that  $f: [a, b) \rightarrow \mathbb{R}$  is Riemann integrable on  $[a, c]$  for each  $c \in [a, b)$ . Then  $\int_a^b f(x) dx$  exists if and only if, for each  $\epsilon > 0$ , there exists  $c_\epsilon \in [a, b)$  such that*

$$\left| \int_c^{c'} f(x) dx \right| < \epsilon$$

for all  $c \leq c'$  with  $c_\epsilon \leq c \leq c' < b$ .

And, as for infinite series, there is a notion of absolute convergence:

**Definition 8.2.3.** Let  $a \in \mathbb{R}$ , let  $b \in \mathbb{R} \cup \{\infty\}$  such that  $a < b$ , and suppose that  $f: [a, b) \rightarrow \mathbb{R}$  is Riemann integrable on  $[a, c]$  for each  $c \in [a, b)$ . Then  $\int_a^b f(x) dx$  is said to be *absolutely convergent* if  $\int_a^b |f(x)| dx$  exists.

**Theorem 8.2.4.** Let  $a \in \mathbb{R}$ , let  $b \in \mathbb{R} \cup \{\infty\}$  such that  $a < b$ , and suppose that  $f : [a, b) \rightarrow \mathbb{R}$  is Riemann integrable on  $[a, c]$  for each  $c \in [a, b)$ . Then  $\int_a^b f(x) dx$  exists if it is absolutely convergent.

*Proof.* Let  $\epsilon > 0$ . By the Cauchy Criterion, there exists  $c_\epsilon \in [a, b)$  such that

$$\int_c^{c'} |f(x)| dx < \epsilon$$

for all  $c \leq c'$  with  $c_\epsilon \leq c \leq c' < b$ . For any such  $c$  and  $c'$ , we thus have

$$\left| \int_c^{c'} f(x) dx \right| \leq \int_c^{c'} |f(x)| dx < \epsilon.$$

Hence,  $\int_a^b f(x) dx$  exists by the Cauchy criterion.  $\square$

The following are also proven as the corresponding statements about infinite series:

**Proposition 8.2.5.** Let  $a \in \mathbb{R}$ , let  $b \in \mathbb{R} \cup \{\infty\}$  such that  $a < b$ , and let  $f : [a, b) \rightarrow [0, \infty)$  be Riemann integrable on  $[a, c]$  for each  $c \in [a, b)$ . Then  $\int_a^b f(x) dx$  exists if and only if

$$[a, b) \rightarrow [0, \infty), \quad c \mapsto \int_a^c f(x) dx$$

is bounded.

**Theorem 8.2.6** (Comparison Test). Let  $a \in \mathbb{R}$ , let  $b \in \mathbb{R} \cup \{\infty\}$  such that  $a < b$ , and suppose that  $f, g : [a, b) \rightarrow \mathbb{R}$  are Riemann integrable on  $[a, c]$  for each  $c \in [a, b)$ .

- (i) Suppose that  $|f(x)| \leq g(x)$  for  $x \in [a, b)$  and that  $\int_a^b g(x) dx$  exists. Then  $\int_a^b f(x) dx$  converges absolutely.
- (ii) Suppose that  $0 \leq g(x) \leq f(x)$  for  $x \in [a, b)$  and that  $\int_a^b g(x) dx$  does not exist. Then  $\int_a^b f(x) dx$  does not exist.

*Examples.*

1. We want to find out if  $\int_0^\infty \frac{\sin x}{x} dx$  exists or even converges absolutely.

Fix  $c > 0$ , and let  $R > c$ . Integration by parts yields

$$\int_c^R \frac{\sin x}{x} dx = \frac{-\cos x}{x} \Big|_c^R - \int_c^R \frac{\cos x}{x^2} dx.$$

Since

$$\int_c^R \frac{1}{x^2} dx = -\frac{1}{x} \Big|_c^R = -\frac{1}{R} + \frac{1}{c} \xrightarrow{R \rightarrow \infty} \frac{1}{c},$$

we know that  $\int_c^\infty \frac{1}{x^2} dx$  exists. Since  $|\frac{\cos x}{x^2}| \leq \frac{1}{x^2}$  for all  $x > 0$ , the Comparison Test shows that  $\int_c^\infty \frac{\cos x}{x^2} dx$  exists. Since

$$\frac{\cos x}{x} \Big|_c^R = \frac{\cos R}{R} - \frac{\cos c}{c} \xrightarrow{R \rightarrow \infty} -\frac{\cos c}{c},$$

it follows that  $\int_c^\infty \frac{\sin x}{x} dx$  exists. Define

$$f: [0, c] \rightarrow \mathbb{R}, \quad x \mapsto \begin{cases} \frac{\sin x}{x}, & x \neq 0, \\ 1, & x = 0. \end{cases}$$

Since  $\lim_{x \downarrow 0} \frac{\sin x}{x} = 1$ , the function  $f$  is continuous and therefore Riemann integrable. Consequently,

$$\int_0^c \frac{\sin x}{x} dx = \lim_{\epsilon \downarrow 0} \int_\epsilon^c \frac{\sin x}{x} dx = \lim_{\epsilon \downarrow 0} \int_\epsilon^c f(x) dx = \int_0^c f(x) dx$$

exists. Thus the improper integral  $\int_0^\infty \frac{\sin x}{x} dx$  exists.

However,  $\int_0^\infty \frac{\sin x}{x} dx$  does not converge absolutely. To see this, let  $n \in \mathbb{N}$ , and note that

$$\int_0^{n\pi} \frac{|\sin x|}{x} dx = \sum_{k=1}^n \int_{(k-1)\pi}^{k\pi} \frac{|\sin x|}{x} dx \geq \sum_{k=1}^n \frac{1}{k\pi} \int_{(k-1)\pi}^{k\pi} |\sin x| dx = \frac{2}{\pi} \sum_{k=1}^n \frac{1}{k}.$$

Since the harmonic series diverges, it follows that the improper integral  $\int_0^\infty \frac{|\sin x|}{x} dx$  does not exist.

2. We claim that the integral  $\int_{-\infty}^\infty e^{-x^2} dx$  exists.

Let  $R \geq 1$ . As

$$\int_1^R e^{-x} dx = -e^{-x} \Big|_1^R = -e^{-R} + \frac{1}{e} \xrightarrow{R \rightarrow \infty} \frac{1}{e},$$

and since  $e^{-x^2} \leq e^{-x}$  for  $x \geq 1$ , it follows that  $\int_1^\infty e^{-x^2} dx$  and, consequently,  $\int_0^\infty e^{-x^2} dx$  exist. Similarly, we see that  $\int_{-\infty}^0 e^{-x^2} dx$  exists. Hence,  $\int_{-\infty}^\infty e^{-x^2} dx$  exists.

We shall now evaluate it. First, note that

$$\int_{-\infty}^\infty e^{-x^2} dx = \lim_{R \rightarrow \infty} \int_{-R}^R e^{-x^2} dx.$$

We shall evaluate  $\lim_{R \rightarrow \infty} \left( \int_{-R}^R e^{-x^2} dx \right)^2$  instead and then take roots.

Let  $R > 0$ , and note that

$$\begin{aligned} \left( \int_{-R}^R e^{-x^2} dx \right)^2 &= \left( \int_{-R}^R e^{-x^2} dx \right) \left( \int_{-R}^R e^{-y^2} dy \right) \\ &= \int_{-R}^R \int_{-R}^R e^{-(x^2+y^2)} dx dy = \int_{[-R,R]^2} e^{-(x^2+y^2)} \end{aligned}$$

by Fubini's Theorem. Passing to polar coordinates, we obtain

$$\int_{B_R[(0,0)]} e^{-(x^2+y^2)} = \int_0^{2\pi} \int_0^R r e^{-r^2} dr d\theta = 2\pi \left( -\frac{e^{-r^2}}{2} \Big|_0^R \right) = \pi(-e^{-R^2} + 1) \xrightarrow{R \rightarrow \infty} \pi$$

and, *mutatis mutandis*,

$$\int_{B_{\sqrt{2}R}[(0,0)]} e^{-(x^2+y^2)} = \pi(-e^{-2R^2} + 1) \xrightarrow{R \rightarrow \infty} \pi.$$

As  $B_R[(0,0)] \subset [-R, R]^2 \subset B_{\sqrt{2}R}[(0,0)]$ , we have

$$\begin{aligned} \pi(-e^{-R^2} + 1) &= \int_{B_R[(0,0)]} e^{-(x^2+y^2)} \leq \int_{[-R,R]^2} e^{-(x^2+y^2)} \\ &\leq \int_{B_{\sqrt{2}R}[(0,0)]} e^{-(x^2+y^2)} = \pi(-e^{-2R^2} + 1), \end{aligned}$$

so that

$$\lim_{R \rightarrow \infty} \int_{[-R,R]^2} e^{-(x^2+y^2)} = \lim_{R \rightarrow \infty} \left( \int_{-R}^R e^{-x^2} dx \right)^2 = \pi.$$

It follows that

$$\int_{-\infty}^{\infty} e^{-x^2} dx = \sqrt{\pi}.$$

The many parallels between infinite series and improper integrals must not be used to jump to (false) conclusions: there are functions  $f$  for which  $\int_0^{\infty} f(x) dx$  exists, even though  $f(x) \xrightarrow{x \rightarrow \infty} 0$ :

*Example.* For  $n \in \mathbb{N}$ , define

$$f_n: [n-1, n) \rightarrow \mathbb{R}, \quad x \mapsto \begin{cases} n, & x \in [n-1, (n-1) + \frac{1}{n^3}), \\ 0, & \text{otherwise,} \end{cases}$$

and define  $f: [0, \infty) \rightarrow \mathbb{R}$  by letting  $f(x) := f_n(x)$  if  $x \in [n-1, n)$ . Clearly,  $f(x) \xrightarrow{x \rightarrow \infty} 0$ .

Let  $R \geq 0$ , and choose  $n \in \mathbb{N}$  such that  $n \geq R$ . It follows that

$$\int_0^R f(x) dx \leq \int_0^n f(x) dx = \sum_{k=1}^n \int_{k-1}^k f_k(x) dx = \sum_{k=1}^n \frac{k}{k^3} \leq \sum_{k=1}^{\infty} \frac{1}{k^2}.$$

Hence,  $\int_0^{\infty} f(x) dx$  exists.

The parallels between infinite series and improper integrals are put to use in the following convergence test:

**Theorem 8.2.7** (Integral Comparison Test). *Let  $f : [1, \infty) \rightarrow [0, \infty)$  be a decreasing function such that  $f$  is Riemann integrable on  $[1, R]$  for each  $R > 1$ . Then the following are equivalent:*

$$(i) \sum_{k=1}^{\infty} f(k) < \infty;$$

$$(ii) \int_1^{\infty} f(x) dx \text{ exists.}$$

*Proof.* (i)  $\implies$  (ii): Let  $R \geq 1$  and choose  $n \in \mathbb{N}$  such that  $n \geq R$ . Then

$$\int_1^R f(x) dx \leq \int_1^n f(x) dx = \sum_{k=1}^{n-1} \int_k^{k+1} f(x) dx \leq \sum_{k=1}^{n-1} \int_k^{k+1} f(k) dx = \sum_{k=1}^{n-1} f(k).$$

Since  $\sum_{k=1}^{\infty} f(k) < \infty$ , it follows that  $\int_1^{\infty} f(x) dx$  exists.

(ii)  $\implies$  (i): Let  $n \in \mathbb{N}$ , and note that

$$\begin{aligned} \sum_{k=1}^n f(k) &= f(1) + \sum_{k=2}^n \int_{k-1}^k f(k) dx \\ &\leq f(1) + \sum_{k=2}^n \int_{k-1}^k f(x) dx \\ &= f(1) + \int_1^n f(x) dx \\ &\leq f(1) + \int_1^{\infty} f(x) dx. \end{aligned}$$

Hence,  $\sum_{k=1}^{\infty} f(k)$  converges. □

*Examples.*

1. Let  $p > 0$  and  $R > 1$ , so that

$$\int_1^R \frac{1}{x^p} dx = \begin{cases} \log R & \text{if } p = 1, \\ \frac{1}{1-p} \left( \frac{1}{R^{p-1}} - 1 \right) & \text{if } p \neq 1. \end{cases}$$

It follows that  $\int_1^{\infty} \frac{1}{x^p} dx$  exists if and only if  $p > 1$ . Consequently,  $\sum_{k=1}^{\infty} \frac{1}{k^p}$  converges if and only if  $p > 1$ .

2. Let  $R > 2$ . A change of variables yields

$$\int_2^R \frac{1}{x \log x} dx = \int_{\log 2}^{\log R} \frac{1}{u} du = \log u \Big|_{\log 2}^{\log R} = \log(\log R) - \log(\log 2).$$

Consequently,  $\int_2^\infty \frac{1}{x \log x} dx$  does not exist, and thus  $\sum_{k=2}^\infty \frac{1}{k \log k}$  diverges.

3. Does the series  $\sum_{k=1}^\infty \frac{\log k}{k^2}$  converge?

Let

$$f: [1, \infty) \rightarrow \mathbb{R}, \quad x \mapsto \frac{\log x}{x^2}.$$

It follows that

$$f'(x) = \frac{x - 2x \log x}{x^4} \leq 0$$

for  $x \geq 3$ . Hence,  $f$  is decreasing on  $[3, \infty)$ : this is sufficient for the integral comparison test to be applicable. Let  $R > 1$ , and note that

$$\int_1^R \frac{\log x}{x^2} dx = \underbrace{-\frac{\log x}{x} \Big|_1^R}_{R \rightarrow \infty \rightarrow 0} + \underbrace{\int_1^R \frac{1}{x^2} dx}_{= -\frac{1}{x} \Big|_1^{R \rightarrow \infty} \rightarrow 1} \rightarrow 1.$$

Hence,  $\int_1^\infty \frac{\log x}{x^2} dx$  exists, and  $\sum_{k=1}^\infty \frac{\log k}{k^2}$  converges.

4. For which  $\theta > 0$  does  $\sum_{k=1}^\infty (\sqrt[k]{\theta} - 1)$  converge?

Let

$$f: [1, \infty) \rightarrow \mathbb{R}, \quad x \mapsto \theta^{\frac{1}{x}} - 1.$$

First consider the case where  $\theta \geq 1$ . Since

$$f'(x) = -\frac{\log \theta}{x^2} \theta^{\frac{1}{x}} \leq 0,$$

and  $f(x) \geq 0$  for  $x \geq 1$ , the integral comparison test is applicable. For any  $x \geq 1$ , there exists  $\xi \in (0, \frac{1}{x})$  such that

$$\frac{\theta^{\frac{1}{x}} - 1}{\frac{1}{x}} = \theta^\xi \log \theta \geq \log \theta,$$

so that

$$\theta^{\frac{1}{x}} - 1 \geq \frac{\log \theta}{x}$$



for  $x \geq 1$ . Since  $\int_1^\infty \frac{1}{x} dx$  does not exist, the comparison test yields that  $\int_1^\infty f(x) dx$  does not exist either unless  $\theta = 1$ . Consequently, if  $\theta \geq 1$ , the series  $\sum_{k=1}^\infty (\sqrt[k]{\theta} - 1)$  converges only if  $\theta = 1$ .

Consider now the case where  $\theta \leq 1$ , the same argument with  $-f$  instead of  $f$  shows that  $\sum_{k=1}^\infty (\sqrt[k]{\theta} - 1)$  converges only if  $\theta = 1$ .

Thus for  $\theta > 0$ , the infinite series  $\sum_{k=1}^\infty (\sqrt[k]{\theta} - 1)$  converges if and only if  $\theta = 1$ .

### Exercises

1. Determine whether or not the improper integral

$$\int_0^\infty e^{-\alpha x} \cos(\beta x) dx$$

exists for  $\alpha > 0$ , and evaluate it if possible.

2. Determine whether or not the improper integral

$$\int_{-1}^1 \frac{1}{\sqrt{1-x^2}} dx$$

exists, and evaluate it if possible.

3. Let  $f: [a, b] \rightarrow \mathbb{R}$  be Riemann integrable. Show that

$$\int_a^b f(x) dx = \lim_{c \uparrow b} \int_a^c f(x) dx.$$

4. Determine whether or not the following improper integrals exist:

- (a)  $\int_0^\infty \frac{x}{\sqrt{1+x^3}} dx$ ;  
 (b)  $\int_0^1 \frac{dx}{\sqrt{\sin x}}$ ;  
 (c)  $\int_0^\infty \sin(x^2) dx$ .

(Hint for (c): Substitute  $x = \sqrt{u}$ .)

5. Show that the improper integral

$$\int_0^\infty \frac{\cos x}{1+x} dx$$

exists, but does not converge absolutely.

6. For  $a \in \mathbb{R}$  and  $b \in \mathbb{R} \cup \{\infty\}$  with  $a < b$ , let  $f, g: [a, b) \rightarrow \mathbb{R}$  be such that such that:

- (a)  $f$  and  $g$  are both Riemann integrable on  $[a, c]$  for each  $c \in [a, b)$ ;

(b)  $\int_a^b f(x) dx$  converges absolutely;

(c)  $g$  is bounded.

Show that  $\int_a^b f(x)g(x) dx$  converges absolutely.

If  $\int_a^b f(x) dx$  is only required to converge, does then  $\int_a^b f(x)g(x) dx$  necessarily converge?

7. Let  $a \in \mathbb{R}$ , let  $b \in \mathbb{R} \cup \{\infty\}$  with  $b > a$ , and let  $f : [a, b) \rightarrow \mathbb{R}$  be such that  $f$  is Riemann integrable on  $[a, c]$  for each  $c \in (a, b)$ . Define  $f^+, f^- : [a, b) \rightarrow \mathbb{R}$  by letting

$$f^+(x) := \begin{cases} f(x), & f(x) \geq 0, \\ 0, & \text{otherwise} \end{cases} \quad \text{and} \quad f^-(x) := \begin{cases} -f(x), & f(x) \leq 0, \\ 0, & \text{otherwise} \end{cases}$$

for  $x \in [a, b)$ . Show that  $\int_a^b f(x) dx$  is absolutely convergent if and only if both  $\int_a^b f^+(x) dx$  and  $\int_a^b f^-(x) dx$  exist.

8. Determine those  $p > 0$  for which the series  $\sum_{k=10}^{\infty} \frac{1}{k(\log k)(\log(\log k))^p}$  converges.

9. *The Gamma Function.*

(a) Show that, for all  $x > 0$ , the improper integral

$$\Gamma(x) := \int_0^{\infty} t^{x-1} e^{-t} dt$$

exists. (*Hint:* Show that  $t^{x-1} e^{-t} \leq \frac{1}{t^2}$  for sufficiently large  $t$ .)

(b) Show that

$$x \Gamma(x) = \Gamma(x + 1) \quad (x > 0).$$

(*Hint:* Integration by parts.)

(c) Conclude that  $\Gamma(n + 1) = n!$  for  $n \in \mathbb{N}_0$ .

## Chapter 9

# Sequences and Series of Functions

### 9.1 Uniform Convergence

**Definition 9.1.1.** Let  $\emptyset \neq D \subset \mathbb{R}^N$ , and let  $f, f_1, f_2, \dots$  be  $\mathbb{R}$ -valued functions on  $D$ . Then the sequence  $(f_n)_{n=1}^\infty$  is said to converge *pointwise* to  $f$  on  $D$  if

$$\lim_{n \rightarrow \infty} f_n(x) = f(x)$$

for each  $x \in D$ .

*Example.* For  $n \in \mathbb{N}$ , let

$$f_n: [0, 1] \rightarrow \mathbb{R}, \quad x \mapsto x^n$$

and

$$f: [0, 1] \rightarrow \mathbb{R}, \quad x \mapsto \begin{cases} 0, & x \in [0, 1), \\ 1, & x = 1. \end{cases}$$

Notice that  $f_n \rightarrow f$  pointwise on  $[0, 1]$ .

This example illustrates a problem with the notion of pointwise convergence: each of the  $f_n$  functions is continuous whereas  $f$  clearly isn't. To find a better notion of convergence, let us carefully examine the definition of pointwise convergence:

$(f_n)_{n=1}^\infty$  converges pointwise to  $f$  if, for each  $x \in D$  and each  $\epsilon > 0$ , there exists  $n_{x,\epsilon} \in \mathbb{N}$  such that  $|f_n(x) - f(x)| < \epsilon$  for all  $n \geq n_{x,\epsilon}$ .

Here the threshold  $n_{x,\epsilon}$  depends both on  $x \in D$  and on  $\epsilon > 0$ .

The key to a better notion of convergence to functions is to remove the dependence of  $n_{x,\epsilon}$  on  $x$ :

**Definition 9.1.2.** Let  $\emptyset \neq D \subset \mathbb{R}^N$ , and let  $f, f_1, f_2, \dots$  be  $\mathbb{R}$ -valued functions on  $D$ . Then the sequence  $(f_n)_{n=1}^\infty$  is said to converge *uniformly* to  $f$  on  $D$  if, for each  $\epsilon > 0$ , there exists  $n_\epsilon \in \mathbb{N}$  such that  $|f_n(x) - f(x)| < \epsilon$  for all  $n \geq n_\epsilon$  and for all  $x \in D$ .

*Example.* For  $n \in \mathbb{N}$ , let

$$f_n: \mathbb{R} \rightarrow \mathbb{R}, \quad x \mapsto \frac{\sin(n\pi x)}{n}.$$

Since

$$\left| \frac{\sin(n\pi x)}{n} \right| \leq \frac{1}{n}$$

for all  $x \in \mathbb{R}$  and  $n \in \mathbb{N}$ , it follows that  $f_n \rightarrow 0$  uniformly on  $\mathbb{R}$ .

**Theorem 9.1.3.** Let  $\emptyset \neq D \subset \mathbb{R}^N$ , and let  $f, f_1, f_2, \dots$  be functions on  $D$  such that  $f_n \rightarrow f$  uniformly on  $D$  and such that  $f_1, f_2, \dots$  are continuous. Then  $f$  is continuous.

*Proof.* Let  $\epsilon > 0$ , and let  $x_0 \in D$ . Choose  $n_\epsilon \in \mathbb{N}$  such that

$$|f_n(x) - f(x)| < \frac{\epsilon}{3}$$

for all  $n \geq n_\epsilon$  and for all  $x \in D$ . Since  $f_{n_\epsilon}$  is continuous, there exists  $\delta > 0$  such that  $|f_{n_\epsilon}(x) - f_{n_\epsilon}(x_0)| < \frac{\epsilon}{3}$  for all  $x \in D$  with  $\|x - x_0\| < \delta$ . For any such  $x$  we obtain

$$|f(x) - f(x_0)| \leq \underbrace{|f(x) - f_{n_\epsilon}(x)|}_{< \frac{\epsilon}{3}} + \underbrace{|f_{n_\epsilon}(x) - f_{n_\epsilon}(x_0)|}_{< \frac{\epsilon}{3}} + \underbrace{|f_{n_\epsilon}(x_0) - f(x_0)|}_{< \frac{\epsilon}{3}} < \epsilon.$$

Hence,  $f$  is continuous at  $x_0$ . Since  $x_0 \in D$  was arbitrary,  $f$  is continuous on all of  $D$ .  $\square$

**Corollary 9.1.4.** Let  $\emptyset \neq D \subset \mathbb{R}^N$  have content, and let  $(f_n)_{n=1}^\infty$  be a sequence of continuous functions on  $D$  that converges uniformly on  $D$  to  $f: D \rightarrow \mathbb{R}$ . Then

$$\int_D f = \lim_{n \rightarrow \infty} \int_D f_n.$$

*Proof.* Let  $\epsilon > 0$ . Choose  $n_\epsilon \in \mathbb{N}$  such that

$$|f_n(x) - f(x)| < \frac{\epsilon}{\mu(D) + 1}$$

for all  $x \in D$  and  $n \geq n_\epsilon$ . For any  $n \geq n_\epsilon$ ,

$$\left| \int_D f_n - \int_D f \right| \leq \int_D |f_n - f| \leq \int_D \frac{\epsilon}{\mu(D) + 1} = \frac{\epsilon \mu(D)}{\mu(D) + 1} < \epsilon.$$

This proves the claim.  $\square$

Unlike integration, differentiation cannot be interchanged with uniform limits:

*Example.* For  $n \in \mathbb{N}$ , let

$$f_n: [0, 1] \rightarrow \mathbb{R}, \quad x \mapsto \frac{x^n}{n},$$

so that  $f_n \rightarrow 0$  uniformly on  $[0, 1]$ . Nevertheless, since

$$f'_n(x) = x^{n-1}$$

for  $x \in [0, 1]$  and  $n \in \mathbb{N}$ , it follows that  $f'_n \not\rightarrow 0$  (not even pointwise).

**Theorem 9.1.5.** Let  $a < b$ , and let  $(f_n)_{n=1}^{\infty}$  be a sequence of continuously differentiable functions on  $[a, b]$  such that:

- (a)  $(f_n(x_0))_{n=1}^{\infty}$  converges at some  $x_0 \in [a, b]$ ;
- (b)  $(f'_n)_{n=1}^{\infty}$  is uniformly convergent.

Then there exists a continuously differentiable function  $f : [a, b] \rightarrow \mathbb{R}$  such that  $f_n \rightarrow f$  and  $f'_n \rightarrow f'$  uniformly on  $[a, b]$ .

*Proof.* Let  $g : [a, b] \rightarrow \mathbb{R}$  be such that  $\lim_{n \rightarrow \infty} f'_n = g$  uniformly on  $[a, b]$ , and let  $y_0 := \lim_{n \rightarrow \infty} f_n(x_0)$ . Define

$$f : [a, b] \rightarrow \mathbb{R}, \quad x \mapsto y_0 + \int_{x_0}^x g(t) dt.$$

It follows that  $f' = g$ , so that  $f'_n \rightarrow f'$  uniformly on  $[a, b]$ .

Let  $\epsilon > 0$ , and choose  $n_\epsilon \in \mathbb{N}$  such that  $|f'_n(x) - g(x)| < \frac{\epsilon}{2(b-a)}$  and  $|f_n(x_0) - y_0| < \frac{\epsilon}{2}$  for all  $x \in [a, b]$  and  $n \geq n_\epsilon$ . For any  $n \geq n_\epsilon$  and  $x \in [a, b]$ ,

$$\begin{aligned} |f_n(x) - f(x)| &= \left| f_n(x_0) + \int_{x_0}^x f'_n(t) dt - y_0 - \int_{x_0}^x g(t) dt \right| \\ &\leq |f_n(x_0) - y_0| + \left| \int_{x_0}^x [f'_n(t) - g(t)] dt \right| \\ &< \frac{\epsilon}{2} + \int_{x_0}^x |f'_n(t) - g(t)| dx \\ &< \frac{\epsilon}{2} + \frac{\epsilon|x - x_0|}{2(b-a)} \\ &< \frac{\epsilon}{2} + \frac{\epsilon}{2} = \epsilon. \end{aligned}$$

This proves that  $f_n \rightarrow f$  uniformly on  $[a, b]$ . □

**Definition 9.1.6.** Let  $\emptyset \neq D \subset \mathbb{R}^N$ . A sequence  $(f_n)_{n=1}^{\infty}$  of  $\mathbb{R}$ -valued functions on  $D$  is called a *uniform Cauchy sequence* on  $D$  if, for each  $\epsilon > 0$ , there exists  $n_\epsilon \in \mathbb{N}$  such that  $|f_n(x) - f_m(x)| < \epsilon$  for all  $x \in D$  and all  $n, m \geq n_\epsilon$ .

**Theorem 9.1.7.** Let  $\emptyset \neq D \subset \mathbb{R}^N$ , and let  $(f_n)_{n=1}^{\infty}$  be a sequence of  $\mathbb{R}$ -valued functions on  $D$ . Then the following are equivalent:

- (i) there exists a function  $f : D \rightarrow \mathbb{R}$  such that  $f_n \rightarrow f$  uniformly on  $D$ ;
- (ii)  $(f_n)_{n=1}^{\infty}$  is a uniform Cauchy sequence on  $D$ .

*Proof.*

(i)  $\implies$  (ii): Let  $\epsilon > 0$  and choose  $n_\epsilon \in \mathbb{N}$  such that

$$|f_n(x) - f(x)| < \frac{\epsilon}{2}$$

for all  $x \in D$  and  $n \geq n_\epsilon$ . For  $x \in D$  and  $n, m \geq n_\epsilon$ , we thus obtain:

$$|f_n(x) - f_m(x)| \leq |f_n(x) - f(x)| + |f(x) - f_m(x)| < \frac{\epsilon}{2} + \frac{\epsilon}{2} = \epsilon.$$

This proves (ii).

(ii)  $\implies$  (i): At each  $x \in D$ , the sequence  $(f_n(x))_{n=1}^\infty$  is a Cauchy sequence in  $\mathbb{R}$  and therefore convergent. Define

$$f: D \rightarrow \mathbb{R}, \quad x \mapsto \lim_{n \rightarrow \infty} f_n(x).$$

Let  $\epsilon > 0$  and choose  $n_\epsilon \in \mathbb{N}$  such that

$$|f_n(x) - f_m(x)| < \frac{\epsilon}{2}$$

for all  $x \in D$  and all  $n, m \geq n_\epsilon$ . Fix  $x \in D$  and  $n \geq n_\epsilon$ . Thus

$$|f_n(x) - f(x)| = \lim_{m \rightarrow \infty} |f_n(x) - f_m(x)| \leq \frac{\epsilon}{2} < \epsilon.$$

Hence,  $(f_n)_{n=1}^\infty$  converges to  $f$  not only pointwise, but uniformly.  $\square$

**Theorem 9.1.8** (Weierstraß  $M$ -Test). *Let  $\emptyset \neq D \subset \mathbb{R}^N$ , let  $(f_k)_{k=1}^\infty$  be a sequence of  $\mathbb{R}$ -valued functions on  $D$ , and suppose that, for each  $k \in \mathbb{N}$ , there exists  $M_k \geq 0$  such that  $|f_k(x)| \leq M_k$  for  $x \in D$  and such that  $\sum_{k=1}^\infty M_k < \infty$ . Then  $\sum_{k=1}^\infty f_k$  converges uniformly and absolutely on  $D$ .*

*Proof.* Let  $\epsilon > 0$  and choose  $n_\epsilon \in \mathbb{N}$  such that

$$\sum_{k=m+1}^n M_k < \epsilon$$

for all  $n > m \geq n_\epsilon$ . For all such  $n$  and  $m$  and for all  $x \in D$ , we obtain that

$$\left| \sum_{k=1}^n f_k(x) - \sum_{k=1}^m f_k(x) \right| \leq \sum_{k=m+1}^n |f_k(x)| \leq \sum_{k=m+1}^n M_k < \epsilon.$$

Hence, the sequence  $(\sum_{k=1}^n f_k)_{n=1}^\infty$  is uniformly Cauchy on  $D$  and thus uniformly convergent. It is easy to see that the convergence is even absolute.  $\square$

*Example.* Let  $R > 0$ , and note that

$$\left| \frac{x^k}{k!} \right| \leq \frac{R^k}{k!}$$

for all  $k \in \mathbb{N}_0$  and  $x \in [-R, R]$ . Since  $\sum_{k=0}^{\infty} \frac{R^k}{k!} < \infty$ , it follows from the  $M$ -test that  $\sum_{k=0}^{\infty} \frac{x^k}{k!}$  converges uniformly on  $[-R, R]$ . From Theorem 9.1.3, we conclude that  $\exp$  is continuous on  $[-R, R]$ . Since  $R > 0$  was arbitrary, we obtain the continuity of  $\exp$  on all of  $\mathbb{R}$ . Let  $x \in \mathbb{R}$  be arbitrary. Then there exists a sequence  $(q_n)_{n=1}^{\infty}$  in  $\mathbb{Q}$  such that  $x = \lim_{n \rightarrow \infty} q_n$ . Since  $\exp(q) = e^q$  for all  $q \in \mathbb{Q}$ , and since both  $\exp$  and the exponential function are continuous, we obtain

$$\exp(x) = \lim_{n \rightarrow \infty} \exp(q_n) = \lim_{n \rightarrow \infty} e^{q_n} = e^x.$$

**Theorem 9.1.9** (Dini's Lemma). *Let  $\emptyset \neq K \subset \mathbb{R}^N$  be compact and let  $(f_n)_{n=1}^{\infty}$  be a sequence of continuous functions on  $K$  that decreases pointwise to a continuous function  $f: K \rightarrow \mathbb{R}$ . Then  $(f_n)_{n=1}^{\infty}$  converges to  $f$  uniformly on  $K$ .*

*Proof.* Let  $\epsilon > 0$ . For each  $n \in \mathbb{N}$ , let

$$V_n := \{x \in K : f_n(x) - f(x) < \epsilon\}.$$

Since each  $f_n - f$  is continuous, there exists an open set  $U_n \subset \mathbb{R}^N$  such that  $U_n \cap K = V_n$ . Let  $x \in K$ . Since  $\lim_{n \rightarrow \infty} f_n(x) = f(x)$ , there exists  $n_0 \in \mathbb{N}$  such that  $f_{n_0}(x) - f(x) < \epsilon$ , i.e.  $x \in V_{n_0}$ . It follows that

$$K = \bigcup_{n=1}^{\infty} V_n \subset \bigcup_{n=1}^{\infty} U_n.$$

Since  $K$  is compact, there exist  $n_1, \dots, n_k \in \mathbb{N}$  such that  $K \subset U_{n_1} \cup \dots \cup U_{n_k}$  and hence  $K = V_{n_1} \cup \dots \cup V_{n_k}$ . Let  $n_{\epsilon} := \max\{n_1, \dots, n_k\}$ . Since  $(f_n)_{n=1}^{\infty}$  is a decreasing sequence, the sequence  $(V_n)_{n=1}^{\infty}$  is an increasing sequence of sets. Hence, we have for  $n \geq n_{\epsilon}$  that

$$V_n \supset V_{n_{\epsilon}} \supset V_{n_j}$$

for  $j = 1, \dots, k$ , and thus  $V_n = K$ . For  $n \geq n_{\epsilon}$  and  $x \in K$ , we thus have  $x \in V_n$  and therefore

$$|f_n(x) - f(x)| = f_n(x) - f(x) < \epsilon.$$

That is,  $(f_n)_{n=1}^{\infty}$  converges to  $f$  uniformly on  $K$ . □

### Exercises

1. Let  $\emptyset \neq D \subset \mathbb{R}^N$ , and let  $f, f_1, f_2, \dots: D \rightarrow \mathbb{R}$ . The sequence  $(f_n)_{n=1}^{\infty}$  is said to converge to  $f$  *locally uniformly* on  $D$  if, for each  $x \in D$ , there exists a neighborhood  $U$  of  $x$  such that  $(f_n)_{n=1}^{\infty}$  converges to  $f$  uniformly on  $U \cap D$ .

Let  $\emptyset \neq K \subset \mathbb{R}^N$  be compact, and let  $f, f_1, f_2, \dots: K \rightarrow \mathbb{R}$  be such that  $(f_n)_{n=1}^\infty$  converges to  $f$  locally uniformly on  $K$ . Show that  $(f_n)_{n=1}^\infty$  converges to  $f$  uniformly on  $K$ .

2. Let  $\emptyset \neq K \subset \mathbb{R}^N$  and  $\emptyset \neq L \subset \mathbb{R}^M$  be compact, let  $F: K \times L \rightarrow \mathbb{R}$  be continuous, and let  $(y_n)_{n=1}^\infty$  be a sequence in  $L$ . For  $n \in \mathbb{N}$ , Let

$$f_n: K \rightarrow \mathbb{R}, \quad x \mapsto F(x, y_n).$$

Show that  $(f_n)_{n=1}^\infty$  has a subsequence that converges uniformly on  $K$ .

3. For  $n \in \mathbb{N}$ , let

$$f_n: [0, \infty) \rightarrow \mathbb{R}, \quad x \mapsto \frac{x}{n^2} e^{-\frac{x}{n}}.$$

Show that  $f_n \rightarrow 0$  uniformly on  $[0, \infty)$ , but that

$$\lim_{n \rightarrow \infty} \int_0^\infty f_n(x) dx = 1.$$

Why doesn't this contradict Corollary 9.1.4?

4. Show that the series  $\sum_{k=0}^\infty \frac{x^k}{k!}$  does *not* uniformly converge to  $e^x$  on all of  $\mathbb{R}$ .
5. Let  $\emptyset \neq D \subset \mathbb{R}^N$ , and let  $(f_n)_{n=1}^\infty$  be a sequence of  $\mathbb{R}$ -valued functions on  $D$  that converges to  $f: D \rightarrow \mathbb{R}$  uniformly on  $D$ . Show that, if  $g: \mathbb{R} \rightarrow \mathbb{R}$  is uniformly continuous, then  $(g \circ f_n)_{n=1}^\infty$  converges to  $g \circ f$  uniformly on  $D$ .
6. Let  $\emptyset \neq D \subset \mathbb{R}^N$  have content, and let  $(f_n)_{n=1}^\infty$  be a sequence of Riemann-integrable functions on  $D$  that converges uniformly to a function  $f: D \rightarrow \mathbb{R}$ . Show that  $f$  is Riemann-integrable as well such that

$$\int_D f = \lim_{n \rightarrow \infty} \int_D f_n.$$

Give an example of a sequence of Riemann-integrable functions on  $[0, 1]$  that converges pointwise to a bounded, but not Riemann-integrable function.

## 9.2 Power Series

Power series can be thought of as “polynomials of infinite degree”:

**Definition 9.2.1.** Let  $x_0 \in \mathbb{R}$ , and let  $a_0, a_1, a_2, \dots \in \mathbb{R}$ . The *power series* about  $x_0$  with coefficients  $a_0, a_1, a_2, \dots$  is the infinite series of functions  $\sum_{n=0}^\infty a_n(x - x_0)^n$ .

This definitions makes *no* assertion whatsoever about convergence of the series. Whether or not  $\sum_{n=0}^\infty a_n(x - x_0)^n$  converges depends, of course, on  $x$ , and the natural question that comes up immediately is: Which are the  $x \in \mathbb{R}$  for which  $\sum_{n=0}^\infty a_n(x - x_0)^n$  converges?



*Examples.*

1. Trivially, each power series  $\sum_{n=0}^{\infty} a_n(x - x_0)^n$  converges for  $x = x_0$ .
2. The power series  $\sum_{n=0}^{\infty} \frac{x^n}{n!}$  converges for all  $x \in \mathbb{R}$ .
3. The power series  $\sum_{n=0}^{\infty} n^n(x - \pi)^n$  converges only for  $x = \pi$ .
4. The power series  $\sum_{n=0}^{\infty} x^n$  converges if and only if  $x \in (-1, 1)$ .

**Theorem 9.2.2.** *Let  $x_0 \in \mathbb{R}$ , let  $a_0, a_1, a_2, \dots \in \mathbb{R}$ , and let  $R > 0$  be such that the sequence  $(a_n R^n)_{n=0}^{\infty}$  is bounded. Then the power series*

$$\sum_{n=0}^{\infty} a_n(x - x_0)^n \quad \text{and} \quad \sum_{n=1}^{\infty} n a_n(x - x_0)^{n-1}$$

*converge uniformly and absolutely on  $[x_0 - r, x_0 + r]$  for each  $r \in (0, R)$ .*

*Proof.* Let  $C \geq 0$  such that  $|a_n|R^n \leq C$  for all  $n \in \mathbb{N}_0$ . Let  $r \in (0, R)$ , and let  $x \in [x_0 - r, x_0 + r]$ . It follows that

$$n|a_n||x - x_0|^{n-1} \leq n|a_n|r^{n-1} = n \left(\frac{r}{R}\right)^{n-1} \frac{|a_n|R^n}{R} \leq n \frac{C}{R} \left(\frac{r}{R}\right)^{n-1}.$$

Since  $\frac{r}{R} \in (0, 1)$ , the series  $\sum_{n=1}^{\infty} n \left(\frac{r}{R}\right)^{n-1}$  converges. By the Weierstraß  $M$ -Test, the power series  $\sum_{n=1}^{\infty} n a_n(x - x_0)^{n-1}$  converges uniformly and absolutely on  $[x_0 - r, x_0 + r]$ .

The corresponding claim for  $\sum_{n=0}^{\infty} a_n(x - x_0)^n$  is proven analogously.  $\square$

**Definition 9.2.3.** Let  $\sum_{n=0}^{\infty} a_n(x - x_0)^n$  be a power series. The *radius of convergence* of  $\sum_{n=0}^{\infty} a_n(x - x_0)^n$  is defined as

$$R := \sup \{r \geq 0 : (a_n r^n)_{n=0}^{\infty} \text{ is bounded}\},$$

where possibly  $R = \infty$  (in case  $(a_n r^n)_{n=0}^{\infty}$  is bounded for all  $r \geq 0$ ).

If  $\sum_{n=0}^{\infty} a_n(x - x_0)^n$  has radius of convergence  $R$ , then it converges uniformly on  $[x_0 - r, x_0 + r]$  for each  $r \in [0, R)$ , but diverges for each  $x \in \mathbb{R}$  with  $|x - x_0| > R$ : this is an immediate consequence of Theorem 9.2.2 and the fact that  $(a_n r^n)_{n=1}^{\infty}$  converges to zero—and thus is bounded—whenever  $\sum_{n=0}^{\infty} a_n r^n$  converges.

And more is true:

**Corollary 9.2.4.** *Let  $\sum_{n=0}^{\infty} a_n(x - x_0)^n$  be a power series with radius of convergence  $R > 0$ . Then  $\sum_{n=0}^{\infty} a_n(x - x_0)^n$  converges, for each  $r \in (0, R)$ , uniformly and absolutely on  $[x_0 - r, x_0 + r]$  to a  $\mathcal{C}^1$ -function  $f: (x_0 - R, x_0 + R) \rightarrow \mathbb{R}$  with first derivative*

$$f'(x) = \sum_{n=1}^{\infty} n a_n(x - x_0)^{n-1}$$

for  $x \in (x_0 - R, x_0 + R)$ . Moreover,  $F: (x_0 - R, x_0 + R) \rightarrow \mathbb{R}$  given by

$$F(x) := \sum_{n=0}^{\infty} \frac{a_n}{n+1} (x - x_0)^{n+1}$$

for  $x \in (x_0 - R, x_0 + R)$  is an antiderivative of  $f$ .

*Proof.* Apply Theorems 9.2.2 and 9.1.5. □

In short, Corollary 9.2.4 asserts that, within its radius of convergence, a power series can be differentiated and integrated term by term.

*Examples.*

1. For  $x \in (-1, 1)$ , we have

$$\begin{aligned} \sum_{n=1}^{\infty} nx^n &= x \sum_{n=1}^{\infty} nx^{n-1} \\ &= x \sum_{n=0}^{\infty} \frac{d}{dx} x^n \\ &= x \frac{d}{dx} \sum_{n=0}^{\infty} x^n, \quad \text{by Corollary 9.2.4,} \\ &= x \frac{d}{dx} \frac{1}{1-x} \\ &= \frac{x}{(1-x)^2}. \end{aligned}$$

2. For  $x \in (-1, 1)$ , we have

$$\frac{1}{x^2 + 1} = \frac{1}{1 - (-x^2)} = \sum_{n=0}^{\infty} (-1)^n x^{2n}.$$

Corollary 9.2.4 yields  $C \in \mathbb{R}$  such that

$$\arctan x + C = \sum_{n=0}^{\infty} (-1)^n \frac{x^{2n+1}}{2n+1}$$

for all  $x \in (-1, 1)$ . Letting  $x = 0$ , we see that  $C = 0$ , so that

$$\arctan x = \sum_{n=0}^{\infty} (-1)^n \frac{x^{2n+1}}{2n+1}$$

for  $x \in (-1, 1)$ .

3. For  $x \in (0, 2)$ , we have

$$\frac{1}{x} = \frac{1}{1 - (1 - x)} = \sum_{n=0}^{\infty} (1 - x)^n = \sum_{n=0}^{\infty} (-1)^n (x - 1)^n.$$

By Corollary 9.2.4, there exists  $C \in \mathbb{R}$  such that

$$\log x + C = \sum_{n=0}^{\infty} \frac{(-1)^n}{n+1} (x-1)^{n+1} = \sum_{n=1}^{\infty} \frac{(-1)^{n-1}}{n} (x-1)^n$$

for  $x \in (0, 2)$ . Letting  $x = 1$ , we see that  $C = 0$ , so that

$$\log x = \sum_{n=1}^{\infty} \frac{(-1)^{n-1}}{n} (x-1)^n$$

for  $x \in (0, 2)$ .

**Proposition 9.2.5** (Cauchy–Hadamard Formula). *The radius of convergence  $R$  of the power series  $\sum_{n=0}^{\infty} a_n(x - x_0)^n$  is given by*

$$R = \frac{1}{\limsup_{n \rightarrow \infty} \sqrt[n]{|a_n|}},$$

where the convention applies that  $\frac{1}{0} = \infty$  and  $\frac{1}{\infty} = 0$ .

*Proof.* Let

$$R' := \frac{1}{\limsup_{n \rightarrow \infty} \sqrt[n]{|a_n|}}.$$

Let  $x \in \mathbb{R}$  be such that  $0 < |x - x_0| < R'$ , so that

$$\limsup_{n \rightarrow \infty} \sqrt[n]{|a_n|} < \frac{1}{|x - x_0|}.$$

Let  $\theta \in \left( \limsup_{n \rightarrow \infty} \sqrt[n]{|a_n|}, \frac{1}{|x - x_0|} \right)$ . By the definition of  $\limsup$ , there exists  $n_0 \in \mathbb{N}$  such that

$$\sqrt[n]{|a_n|} < \theta$$

for  $n \geq n_0$  and therefore

$$\sqrt[n]{|a_n| |x - x_0|^n} < \theta |x - x_0| < 1$$

for  $n \geq n_0$ . Hence, by the root test,  $\sum_{n=0}^{\infty} a_n(x - x_0)^n$  converges, so that  $R' \leq R$ .

Let  $x \in \mathbb{R}$  such that  $|x - x_0| > R'$ , i.e.,

$$\limsup_{n \rightarrow \infty} \sqrt[n]{|a_n|} > \frac{1}{|x - x_0|}.$$

By Proposition B.1.5, there exists a subsequence  $(a_{n_k})_{k=1}^{\infty}$  of  $(a_n)_{n=0}^{\infty}$  such that  $\limsup_{n \rightarrow \infty} \sqrt[n]{|a_n|} = \lim_{k \rightarrow \infty} \sqrt[n_k]{|a_{n_k}|}$ . Then there exists  $k_0 \in \mathbb{N}$  such that

$$\sqrt[n_k]{|a_{n_k}|} > \frac{1}{|x - x_0|}$$

and hence

$$\sqrt[n_k]{|a_{n_k}|} |x - x_0|^{n_k} > 1$$

for  $k \geq k_0$ . Consequently,  $(a_n(x - x_0)^n)_{n=0}^{\infty}$  does not converge to zero, so that  $\sum_{n=0}^{\infty} a_n(x - x_0)^n$  must diverge. It follows that  $R \leq R'$ .  $\square$

*Examples.*

1. Consider the power series

$$\sum_{n=1}^{\infty} \left(1 + \frac{1}{n}\right)^{n^2} x^n,$$

so that

$$\sqrt[n]{a_n} = \left(1 + \frac{1}{n}\right)^n$$

for  $n \in \mathbb{N}$ . Since

$$\lim_{n \rightarrow \infty} \sqrt[n]{a_n} = \lim_{n \rightarrow \infty} \left(1 + \frac{1}{n}\right)^n = e,$$

the Cauchy–Hadamard Formula tells us that the radius of convergence of the power series is  $\frac{1}{e}$ .

2. We will now use the Cauchy–Hadamard formula to prove that  $\lim_{n \rightarrow \infty} \sqrt[n]{n} = 1$ .

Since  $\sum_{n=1}^{\infty} nx^n$  converges for  $|x| < 1$  and diverges for  $|x| > 1$ , the radius of convergence  $R$  of that series must equal 1. By the Cauchy–Hadamard formula, this means that  $\limsup_{n \rightarrow \infty} \sqrt[n]{n} = 1$ . Hence, 1 is the largest accumulation point of  $(\sqrt[n]{n})_{n=1}^{\infty}$ . Since, trivially,  $\sqrt[n]{n} \geq 1$  for all  $n \in \mathbb{N}$ , all accumulation points of the sequence must be greater or equal to 1. Hence,  $(\sqrt[n]{n})_{n=1}^{\infty}$  has only one accumulation point, namely 1, and therefore converges to 1.

**Definition 9.2.6.** We say that a function  $f$  has a *series expansion* about  $x_0 \in \mathbb{R}$  if  $f(x) = \sum_{n=0}^{\infty} a_n(x - x_0)^n$  for some power series  $\sum_{n=0}^{\infty} a_n(x - x_0)^n$  and all  $x$  in some open interval centered at  $x_0$ .

From Corollary 9.2.4, we obtain immediately:

**Corollary 9.2.7.** *Let  $f$  be a function with a power series expansion  $\sum_{n=0}^{\infty} a_n(x - x_0)^n$  about  $x_0 \in \mathbb{R}$ . Then  $f$  is infinitely often differentiable on an open interval about  $x_0$  such that*

$$a_n = \frac{f^{(n)}(x_0)}{n!}$$

for all  $n \in \mathbb{N}_0$ . In particular, the power series expansion of  $f$  about  $x_0$  is unique.

Let  $f$  be a function that is infinitely often differentiable on some neighborhood of  $x_0 \in \mathbb{R}$ . Then the *Taylor series* of  $f$  at  $x_0$  is the power series  $\sum_{n=0}^{\infty} \frac{f^{(n)}(x_0)}{n!} (x - x_0)^n$ . Corollary 9.2.7 asserts that, whenever  $f$  has a power series expansion about  $x_0$ , then the corresponding power series must be the function's Taylor series. We thus may also speak of the *Taylor expansion* of  $f$  about  $x_0$ .

Does every infinitely often differentiable function have a Taylor expansion?

*Example.* Let  $\mathcal{F}$  be the collection of all functions  $f: \mathbb{R} \rightarrow \mathbb{R}$  of the following form: there exists a polynomial  $p$  such that

$$f(x) = \begin{cases} p\left(\frac{1}{x}\right) e^{-\frac{1}{x^2}}, & x \neq 0, \\ 0, & x = 0, \end{cases} \quad (9.1)$$

for all  $x \in \mathbb{R}$ . It is clear that each  $f \in \mathcal{F}$  is continuous on  $\mathbb{R} \setminus \{0\}$ , and from l'Hospital's Rule, it follows that each  $f \in \mathcal{F}$  is also continuous at  $x = 0$ .

We claim that each  $f \in \mathcal{F}$  is differentiable such that  $f' \in \mathcal{F}$ .

Let  $f \in \mathcal{F}$  be as in (9.1). It is easy to see that  $f$  is differentiable at each  $x \neq 0$  with

$$\begin{aligned} f'(x) &= -\frac{1}{x^2} p' \left( \frac{1}{x} \right) e^{-\frac{1}{x^2}} + p \left( \frac{1}{x} \right) \left( -\frac{2}{x^3} \right) e^{-\frac{1}{x^2}} \\ &= \left( -\frac{1}{x^2} p' \left( \frac{1}{x} \right) - \frac{2}{x^3} p \left( \frac{1}{x} \right) \right) e^{-\frac{1}{x^2}}, \end{aligned}$$

so that

$$f'(x) = q \left( \frac{1}{x} \right) e^{-\frac{1}{x^2}}$$

for such  $x$ , where

$$q(y) := -y^2 p'(y) - 2y^3 p(y)$$

for all  $y \in \mathbb{R}$ . Let  $r(y) := y p(y)$  for  $y \in \mathbb{R}$ , so that  $r$  is a polynomial. Since functions in  $\mathcal{F}$  are continuous at  $x = 0$ , we see that

$$\lim_{\substack{h \rightarrow 0 \\ h \neq 0}} \frac{f(h) - f(0)}{h} = \lim_{\substack{h \rightarrow 0 \\ h \neq 0}} \frac{1}{h} p \left( \frac{1}{h} \right) e^{-\frac{1}{h^2}} = \lim_{\substack{h \rightarrow 0 \\ h \neq 0}} r \left( \frac{1}{h} \right) e^{-\frac{1}{h^2}} = 0.$$

This proves the claim.

Consider

$$f: \mathbb{R} \rightarrow \mathbb{R}, \quad x \mapsto \begin{cases} e^{-\frac{1}{x^2}}, & x \neq 0, \\ 0, & x = 0, \end{cases}$$

so that  $f \in \mathcal{F}$ . By the claim just proven, it follows that  $f$  is a infinitely often differentiable with  $f^{(n)} \in \mathcal{F}$  for all  $n \in \mathbb{N}$ . In particular,  $f^{(n)}(0) = 0$  holds for all  $n \in \mathbb{N}$ . The Taylor series of  $f$  thus converges (to 0) on all of  $\mathbb{R}$ , but  $f$  does not have a Taylor expansion about 0.

**Theorem 9.2.8.** Let  $x_0 \in \mathbb{R}$ , let  $R > 0$ , and let  $f: [x_0 - R, x_0 + R] \rightarrow \mathbb{R}$  be infinitely often differentiable such that the set

$$\left\{ |f^{(n)}(x)| : x \in [x_0 - R, x_0 + R], n \in \mathbb{N}_0 \right\} \quad (9.2)$$

is bounded. Then

$$\sum_{n=0}^{\infty} \frac{f^{(n)}(x_0)}{n!} (x - x_0)^n$$

converges uniformly to  $f(x)$  on  $[x_0 - R, x_0 + R]$ .

*Proof.* Let  $C \geq 0$  be an upper bound for (9.2), and let  $x \in [x_0 - R, x_0 + R]$ . For each  $n \in \mathbb{N}$ , Taylor's Theorem guarantees that

$$f(x) = \sum_{k=0}^n \frac{f^{(k)}(x_0)}{k!} (x - x_0)^k + \frac{f^{(n+1)}(\xi)}{(n+1)!} (x - x_0)^{n+1}$$

for some  $\xi \in [x_0 - R, x_0 + R]$ , so that

$$\left| f(x) - \sum_{k=0}^n \frac{f^{(k)}(x_0)}{k!} (x - x_0)^k \right| = \left| \frac{f^{(n+1)}(\xi)}{(n+1)!} \right| |x - x_0|^{n+1} \leq C \frac{R^{n+1}}{(n+1)!}.$$

Since  $\lim_{n \rightarrow \infty} \frac{R^{n+1}}{(n+1)!} = 0$ , this completes the proof.  $\square$

*Example.* For all  $x \in \mathbb{R}$ ,

$$\sin x = \sum_{n=0}^{\infty} (-1)^n \frac{x^{2n+1}}{(2n+1)!} \quad \text{and} \quad \cos x = \sum_{n=0}^{\infty} (-1)^n \frac{x^{2n}}{(2n)!}.$$

Let  $\sum_{n=0}^{\infty} a_n (x - x_0)^n$  be a power series with radius of convergence  $R$ . What happens at  $x = x_0 \pm R$ ?

In general, nothing can be said.

**Theorem 9.2.9** (Abel's Theorem). Suppose that the series  $\sum_{n=0}^{\infty} a_n$  converges. Then the power series  $\sum_{n=0}^{\infty} a_n x^n$  converges pointwise on  $(-1, 1]$  to a continuous function.

*Proof.* For  $x \in (-1, 1]$ , define

$$f(x) := \sum_{n=0}^{\infty} a_n x^n.$$

Since  $\sum_{n=1}^{\infty} a_n x^n$  converges uniformly on compact subsets of  $(-1, 1)$ , we know that  $f$  is continuous on  $(-1, 1)$ . What remains to be shown is that  $f$  is continuous at 1, i.e.,  $\lim_{x \uparrow 1} f(x) = f(1)$ .

For  $n \in \mathbb{Z}$  with  $n \geq -1$ , define  $r_n := \sum_{k=n+1}^{\infty} a_k$ . It follows that  $r_{-1} = f(1)$ ,  $r_n - r_{n-1} = -a_n$  for all  $n \in \mathbb{N}_0$ , and  $\lim_{n \rightarrow \infty} r_n = 0$ . Since  $(r_n)_{n=-1}^{\infty}$  is bounded, the series  $\sum_{n=0}^{\infty} r_n x^n$  and  $\sum_{n=0}^{\infty} r_{n-1} x^n$  converge for  $x \in (-1, 1)$ . We then find for  $x \in (-1, 1)$  that

$$\begin{aligned} (1-x) \sum_{n=0}^{\infty} r_n x^n &= \sum_{n=0}^{\infty} r_n x^n - \sum_{n=0}^{\infty} r_n x^{n+1} \\ &= \sum_{n=0}^{\infty} r_n x^n - \sum_{n=0}^{\infty} r_{n-1} x^n + r_{-1} \\ &= \sum_{n=0}^{\infty} (r_n - r_{n-1}) x^n + r_{-1} \\ &= - \underbrace{\sum_{n=0}^{\infty} a_n x^n}_{=f(x)} + f(1), \end{aligned}$$

i.e.,

$$f(1) - f(x) = (1-x) \sum_{n=0}^{\infty} r_n x^n.$$

Let  $\epsilon > 0$  and let  $C \geq 0$  be such that  $|r_n| \leq C$  for  $n \geq -1$ . Choose  $n_\epsilon \in \mathbb{N}$  such that  $|r_n| \leq \frac{\epsilon}{2}$  for  $n \geq n_\epsilon$ , and set  $\delta := \frac{\epsilon}{2Cn_\epsilon + 1}$ . Let  $x \in (0, 1)$  such that  $1-x < \delta$ . It follows that

$$\begin{aligned} |f(1) - f(x)| &\leq (1-x) \sum_{n=0}^{\infty} |r_n| x^n \\ &= (1-x) \sum_{n=0}^{n_\epsilon-1} |r_n| x^n + (1-x) \sum_{n=n_\epsilon}^{\infty} |r_n| x^n \\ &\leq (1-x) C n_\epsilon + (1-x) \frac{\epsilon}{2} \sum_{n=n_\epsilon}^{\infty} x^n \\ &< \frac{\epsilon}{2} + (1-x) \frac{\epsilon}{2} \underbrace{\sum_{n=0}^{\infty} x^n}_{=\frac{1}{1-x}} \\ &= \frac{\epsilon}{2} + \frac{\epsilon}{2} \\ &= \epsilon, \end{aligned}$$

so that  $f$  is indeed continuous at 1. □

*Examples.*

1. For  $x \in (-1, 1)$ , the identity

$$\log(x + 1) = \sum_{n=1}^{\infty} \frac{(-1)^{n-1}}{n} x^n \quad (9.3)$$

holds. By Abel's Theorem, the right-hand side of (9.3) defines a continuous function on all of  $(-1, 1]$ . Since the left hand side of (9.3) is also continuous on  $(-1, 1]$ , it follows that (9.3) holds for all  $x \in (-1, 1]$ . Letting  $x = 1$ , we obtain that

$$\sum_{n=1}^{\infty} \frac{(-1)^{n-1}}{n} = \log 2.$$

2. Since

$$\arctan x = \sum_{n=0}^{\infty} (-1)^n \frac{x^{2n+1}}{2n+1}$$

holds for all  $x \in (-1, 1)$ , a similar argument as in the previous example yields that this identity holds for all  $x \in (-1, 1]$ . In particular, letting  $x = 1$  yields

$$\frac{\pi}{4} = \arctan 1 = \sum_{n=0}^{\infty} \frac{(-1)^n}{2n+1}.$$

### ***Exercises***

1. Determine the radii of convergence for the following power series:

- (a)  $\sum_{n=0}^{\infty} \binom{2n}{n} x^n$ ;
- (b)  $\sum_{n=2}^{\infty} (-1)^n \left( \frac{5n+3}{3n-4} \right)^n (x - 2023)^n$ ;
- (c)  $\sum_{n=0}^{\infty} \frac{1}{n^n} (x - e)^n$ ;
- (d)  $\sum_{n=0}^{\infty} \frac{n^n}{n!} (x - 6)^n$ .

2. For the power series

$$\sum_{n=1}^{\infty} \frac{x^n}{n}$$

determine the following:

- (a) its radius of convergence;
  - (b) the set of those  $x$  for which it converges;
  - (c) its value for all such  $x$ .
3. Let  $(a_n)_{n=0}^{\infty}$  be a sequence in  $\mathbb{R}$  such that  $R := \lim_{n \rightarrow \infty} \frac{|a_n|}{|a_{n+1}|}$  exists. Show that  $R$ , for any  $x_0 \in \mathbb{R}$ , is the radius of convergence of the power series  $\sum_{n=0}^{\infty} a_n (x - x_0)^n$ .



4. Show that the power series  $\sum_{n=1}^{\infty} n^2 x^n$  has radius of convergence 1 and that

$$\sum_{n=1}^{\infty} n^2 x^n = \frac{x(x+1)}{(1-x)^3}$$

for  $x \in (-1, 1)$ .

5. For any  $\alpha \in \mathbb{R}$  and  $n \in \mathbb{N}_0$ , let

$$\binom{\alpha}{n} := \prod_{j=1}^n \frac{\alpha - j + 1}{j}.$$

You may use without proving it that

$$\binom{\alpha - 1}{n} + \binom{\alpha - 1}{n - 1} = \binom{\alpha}{n} \quad (9.4)$$

for  $n \in \mathbb{N}$ .

- (a) Show that the *binomial series*  $\sum_{n=0}^{\infty} \binom{\alpha}{n} x^n$  converges on  $(-1, 1)$  to a differentiable function  $f$ .

- (b) Show that  $(1+x)f'(x) = \alpha f(x)$  for  $x \in (-1, 1)$ .

*Hint:* Use (9.4).

- (c) Conclude that

$$\sum_{n=0}^{\infty} \binom{\alpha}{n} x^n = (1+x)^\alpha$$

for  $x \in (-1, 1)$ .

*Hint:* Let  $g(x) := (1+x)^\alpha$ , consider  $f(x)/g(x)$ , and differentiate.

6. Although the theory of power series was developed in class only for real variables, it all works perfectly well over  $\mathbb{C}$  as well. We can thus extend  $\exp$ ,  $\sin$ , and  $\cos$  to  $\mathbb{C}$  by *defining*

$$e^z := \sum_{n=0}^{\infty} \frac{z^n}{n!}, \quad \sin z := \sum_{n=0}^{\infty} (-1)^n \frac{z^{2n+1}}{(2n+1)!}, \quad \text{and} \quad \cos z := \sum_{n=0}^{\infty} (-1)^n \frac{z^{2n}}{(2n)!}$$

for  $z \in \mathbb{C}$ .

Show that

$$e^{iz} = \cos z + i \sin z$$

holds for all  $z \in \mathbb{C}$ , and derive *Euler's Identity*:  $e^{i\pi} + 1 = 0$ .

### 9.3 Fourier Series

The theory of Fourier series is about approximating periodic functions through terms involving sine and cosine.

**Definition 9.3.1.** Let  $\omega > 0$ , and let  $\mathcal{PC}_\omega(\mathbb{R})$  denote the collection of all functions  $f: \mathbb{R} \rightarrow \mathbb{R}$  with the following properties:

- (a)  $f(x + \omega) = f(x)$  for  $x \in \mathbb{R}$ .
- (b) there exists a partition  $-\frac{\omega}{2} = t_0 < t_1 < \dots < t_n = \frac{\omega}{2}$  of  $[-\frac{\omega}{2}, \frac{\omega}{2}]$  such that  $f$  is continuous on  $(t_{j-1}, t_j)$  for  $j = 1, \dots, n$  and such that  $\lim_{t \uparrow t_j} f(t)$  exists for  $j = 1, \dots, n$  and  $\lim_{t \downarrow t_j} f(t)$  exists for  $j = 0, \dots, n - 1$ .

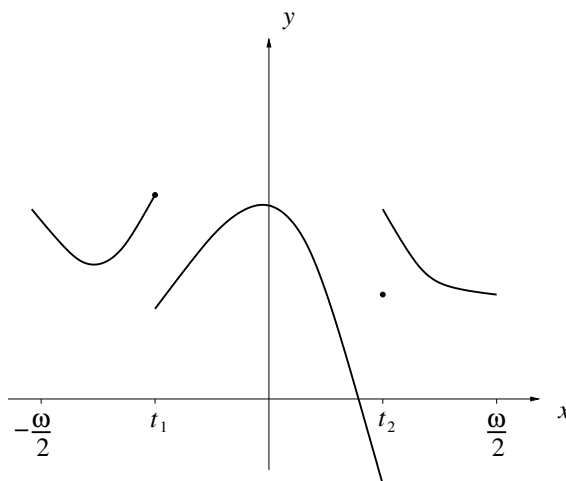

Figure 9.1: A function in  $\mathcal{PC}_\omega(\mathbb{R})$

We will focus on the case where  $\omega = 2\pi$ .

*Example.* The functions  $\sin$  and  $\cos$  belong to  $\mathcal{PC}_{2\pi}(\mathbb{R})$ .

How can we approximate arbitrary  $f \in \mathcal{PC}_{2\pi}(\mathbb{R})$  by linear combinations of  $\sin$  and  $\cos$ ?

**Definition 9.3.2.** For  $f \in \mathcal{PC}_{2\pi}(\mathbb{R})$ , the *Fourier coefficients*  $a_0, a_1, a_2, \dots, b_1, b_2, \dots$  of  $f$  are defined as

$$a_n := \frac{1}{\pi} \int_{-\pi}^{\pi} f(t) \cos(nt) dt$$

for  $n \in \mathbb{N}_0$  and

$$b_n := \frac{1}{\pi} \int_{-\pi}^{\pi} f(t) \sin(nt) dt$$

for  $n \in \mathbb{N}$ . The infinite series  $\frac{a_0}{2} + \sum_{n=1}^{\infty} (a_n \cos(nx) + b_n \sin(nx))$  is called the *Fourier series* of  $f$ . We write

$$f(x) \sim \frac{a_0}{2} + \sum_{n=1}^{\infty} (a_n \cos(nx) + b_n \sin(nx)).$$

The fact that

$$f(x) \sim \frac{a_0}{2} + \sum_{n=1}^{\infty} (a_n \cos(nx) + b_n \sin(nx))$$

does not mean that we have convergence—not even pointwise.

*Example.* Let

$$f: (-\pi, \pi] \rightarrow \mathbb{R}, \quad x \mapsto \begin{cases} -1, & x \in (-\pi, 0), \\ 1, & x \in [0, \pi]. \end{cases}$$

Extend  $f$  to a function in  $\mathcal{PC}_{2\pi}(x)$  (using Definition 9.3.1(a)). For  $n \in \mathbb{N}_0$ , we obtain

$$\begin{aligned} a_n &= \frac{1}{\pi} \int_{-\pi}^{\pi} f(t) \cos(nt) dt \\ &= \frac{1}{\pi} \left( - \int_{-\pi}^0 \cos(nt) dt + \int_0^{\pi} \cos(nt) dt \right) \\ &= \frac{1}{\pi} \left( - \int_0^{\pi} \cos(nt) dt + \int_0^{\pi} \cos(nt) dt \right) \\ &= 0. \end{aligned}$$

For  $n \in \mathbb{N}$ , we have

$$\begin{aligned} b_n &= \frac{1}{\pi} \int_{-\pi}^{\pi} f(t) \sin(nt) dt \\ &= \frac{1}{\pi} \left( - \int_{-\pi}^0 \sin(nt) dt + \int_0^{\pi} \sin(nt) dt \right) \\ &= \frac{1}{\pi} \left( - \frac{1}{n} \int_{-\pi n}^0 \sin(t) dt + \frac{1}{n} \int_0^{\pi n} \sin(t) dt \right) \\ &= \frac{1}{\pi n} \left( \cos t \Big|_{-\pi n}^0 - \cos t \Big|_0^{\pi n} \right) \\ &= \frac{1}{\pi n} (1 - \cos(\pi n) - \cos(n\pi) + 1) \\ &= \frac{2 - 2 \cos(\pi n)}{\pi n} \\ &= \begin{cases} 0, & n \text{ even,} \\ \frac{4}{\pi n}, & n \text{ odd.} \end{cases} \end{aligned}$$

It follows that

$$f(x) \sim \frac{4}{\pi} \sum_{n=0}^{\infty} \frac{1}{2n+1} \sin((2n+1)x).$$

The Fourier series converges to zero whenever  $x$  is an integer multiple of  $\pi$ , i.e., it does *not* converge to  $f$  for such  $x$ .

In general, it is too much to expect pointwise convergence. Suppose that  $f \in \mathcal{PC}_{2\pi}(\mathbb{R})$  has a Fourier series that converges pointwise to  $f$ . Let  $g: \mathbb{R} \rightarrow \mathbb{R}$  be another function in  $\mathcal{PC}_{2\pi}(\mathbb{R})$  obtained from  $f$  by altering  $f$  at finitely many points in  $(-\pi, \pi]$ . Then  $f$  and  $g$  have the same Fourier series, but at those points where  $f$  differs from  $g$ , the series cannot converge pointwise to  $g$ .

We need a different type of convergence.

**Definition 9.3.3.** For  $f \in \mathcal{PC}_{2\pi}(\mathbb{R})$ , define

$$\|f\|_2 := \left( \int_{-\pi}^{\pi} |f(t)|^2 dt \right)^{\frac{1}{2}}.$$

**Proposition 9.3.4.** Let  $f, g \in \mathcal{PC}_{2\pi}(\mathbb{R})$ , and let  $\lambda \in \mathbb{R}$ . Then we have:

- (i)  $\|f\|_2 \geq 0$ ;
- (ii)  $\|\lambda f\|_2 = |\lambda| \|f\|_2$ ;
- (iii)  $\|f + g\|_2 \leq \|f\|_2 + \|g\|_2$ .

*Proof.* (i) and (ii) are obvious.

For (iii), we first claim that

$$\int_{-\pi}^{\pi} |f(t)g(t)| dt \leq \|f\|_2 \|g\|_2 \tag{9.5}$$

Let  $\epsilon > 0$ , and choose a partition  $-\pi = t_0 < \dots < t_n = \pi$  and sample points  $\xi_j \in (t_{j-1}, t_j)$  for  $j = 1, \dots, n$  such that

$$\left| \int_{-\pi}^{\pi} |f(t)g(t)| dt - \sum_{j=1}^n |f(\xi_j)g(\xi_j)|(t_j - t_{j-1}) \right| < \epsilon,$$

$$\left| \left( \int_{-\pi}^{\pi} |f(t)|^2 dt \right)^{\frac{1}{2}} - \left( \sum_{j=1}^n |f(\xi_j)|^2 (t_j - t_{j-1}) \right)^{\frac{1}{2}} \right| < \epsilon,$$

and

$$\left| \left( \int_{-\pi}^{\pi} |g(t)|^2 dt \right)^{\frac{1}{2}} - \left( \sum_{j=1}^n |g(\xi_j)|^2 (t_j - t_{j-1}) \right)^{\frac{1}{2}} \right| < \epsilon.$$

We therefore obtain

$$\begin{aligned}
\int_{-\pi}^{\pi} |f(t)g(t)| dt &< \sum_{j=1}^n |f(\xi_j)g(\xi_j)|(t_j - t_{j-1}) + \epsilon \\
&= \sum_{j=1}^n |f(\xi_j)|(t_j - t_{j-1})^{\frac{1}{2}} |g(\xi_j)|(t_j - t_{j-1})^{\frac{1}{2}} + \epsilon \\
&\leq \left( \sum_{j=1}^n |f(\xi_j)|^2 (t_j - t_{j-1}) \right)^{\frac{1}{2}} \left( \sum_{j=1}^n |g(\xi_j)|^2 (t_j - t_{j-1}) \right)^{\frac{1}{2}} + \epsilon, \\
&\quad \text{by the Cauchy-Schwarz Inequality,} \\
&< \left( \left( \int_{-\pi}^{\pi} |f(t)|^2 dt \right)^{\frac{1}{2}} + \epsilon \right) \left( \left( \int_{-\pi}^{\pi} |g(t)|^2 dt \right)^{\frac{1}{2}} + \epsilon \right) + \epsilon.
\end{aligned}$$

Since  $\epsilon > 0$  is arbitrary, this yields (9.5).

Since

$$\begin{aligned}
\|f + g\|_2^2 &= \int_{-\pi}^{\pi} (f(t)^2 + 2f(t)g(t) + g(t)^2) dt \\
&= \int_{-\pi}^{\pi} |f(t)|^2 dt + 2 \int_{-\pi}^{\pi} f(t)g(t) dt + \int_{-\pi}^{\pi} |g(t)|^2 dt \\
&\leq \|f\|_2^2 + 2 \int_{-\pi}^{\pi} |f(t)g(t)| dt + \|g\|_2^2 \\
&\leq \|f\|_2^2 + 2\|f\|_2\|g\|_2 + \|g\|_2^2, \quad \text{by (9.5),} \\
&= (\|f\|_2 + \|g\|_2)^2,
\end{aligned}$$

which proves (iii).  $\square$

One cannot improve Proposition 9.3.4(i) to  $\|f\|_2 > 0$  for non-zero  $f$ : Any function  $f$  that is different from zero at only finitely many points provides a counterexample.

**Definition 9.3.5.** Let  $\alpha_0, \alpha_1, \dots, \alpha_n, \beta_1, \dots, \beta_n \in \mathbb{R}$ . A function of the form

$$T_n(x) = \frac{\alpha_0}{2} + \sum_{k=1}^n (\alpha_k \cos(kx) + \beta_k \sin(kx)) \quad (9.6)$$

for  $x \in \mathbb{R}$  is called a *trigonometric polynomial* of degree  $n$ .

We note that trigonometric polynomials belong to  $\mathcal{PC}_{2\pi}(\mathbb{R})$ .

**Lemma 9.3.6.** Let  $f \in \mathcal{PC}_{2\pi}(\mathbb{R})$  have the Fourier coefficients  $a_0, a_1, a_2, \dots, b_1, b_2, \dots$  and  $T_n$  be a trigonometric polynomial of degree  $n \in \mathbb{N}$  as in (9.6). Then

$$\begin{aligned}
&\|f - T_n\|_2^2 \\
&= \|f\|_2^2 - \pi \left( \frac{a_0^2}{2} + \sum_{k=1}^n (a_k^2 + b_k^2) \right) + \pi \left( \frac{1}{2} (\alpha_0 - a_0)^2 + \sum_{k=1}^n ((\alpha_k - a_k)^2 + (\beta_k - b_k)^2) \right).
\end{aligned}$$

*Proof.* First note that

$$\|f - T_n\|_2^2 = \underbrace{\int_{-\pi}^{\pi} f(t)^2 dt}_{=\|f\|_2^2} - 2 \int_{-\pi}^{\pi} f(t)T_n(t) dt + \int_{-\pi}^{\pi} T_n(t)^2 dt.$$

Then, observe that

$$\begin{aligned} & \int_{-\pi}^{\pi} f(t)T_n(t) dt \\ &= \frac{\alpha_0}{2} \int_{-\pi}^{\pi} f(t) dt + \sum_{k=1}^n \alpha_k \int_{-\pi}^{\pi} f(t) \cos(kt) dt + \sum_{k=1}^n \beta_k \int_{-\pi}^{\pi} f(t) \sin(kt) dt \\ &= \pi \left( \frac{\alpha_0}{2} a_0 + \sum_{k=1}^n (\alpha_k a_k + \beta_k b_k) \right), \end{aligned}$$

and

$$\begin{aligned} & \int_{-\pi}^{\pi} T_n(t)^2 dt \\ &= 2\pi \frac{\alpha_0^2}{4} + \frac{\alpha_0}{2} \sum_{k=1}^n \left( \underbrace{\alpha_k \int_{-\pi}^{\pi} \cos(kt) dt}_{=0} + \underbrace{\beta_k \int_{-\pi}^{\pi} \sin(kt) dt}_{=0} \right) \\ & \quad + \sum_{k,j=1}^n \left( \alpha_k \alpha_j \int_{-\pi}^{\pi} \cos(kt) \cos(jt) dt + 2\alpha_k \beta_j \int_{-\pi}^{\pi} \cos(kt) \sin(jt) dt \right. \\ & \quad \left. + \beta_k \beta_j \int_{-\pi}^{\pi} \sin(kt) \sin(jt) dt \right) \\ &= \pi \frac{\alpha_0^2}{2} + \sum_{k=1}^n \left( \alpha_k^2 \int_{-\pi}^{\pi} \cos(kt)^2 dt + \beta_k^2 \int_{-\pi}^{\pi} \sin(kt)^2 dt \right) \\ &= \pi \left( \frac{\alpha_0^2}{2} + \sum_{k=1}^n (\alpha_k^2 + \beta_k^2) \right). \end{aligned}$$

We thus obtain

$$\begin{aligned} & \|f - T_n\|_2^2 \\ &= \|f\|_2^2 + \pi \left( -\alpha_0 a_0 - 2 \sum_{k=1}^n (\alpha_k a_k + \beta_k b_k) + \frac{\alpha_0^2}{2} + \sum_{k=1}^n (\alpha_k^2 + \beta_k^2) \right) \\ &= \|f\|_2^2 + \pi \left( \frac{1}{2} (\alpha_0^2 - 2\alpha_0 a_0) + \sum_{k=1}^n (\alpha_k^2 - 2\alpha_k a_k + \beta_k^2 - 2\beta_k b_k) \right) \\ &= \|f\|_2^2 + \pi \left( \frac{1}{2} (\alpha_0 - a_0)^2 + \sum_{k=1}^n ((\alpha_k - a_k)^2 + (\beta_k - b_k)^2) - \frac{1}{2} a_0^2 - \sum_{k=1}^n (a_k^2 + b_k^2) \right) \end{aligned}$$

This proves the claim.  $\square$

**Proposition 9.3.7.** For  $f \in \mathcal{PC}_{2\pi}(\mathbb{R})$  with the Fourier coefficients  $a_0, a_1, a_2, \dots, b_1, b_2, \dots$  and  $n \in \mathbb{N}$ , let  $S_n(f) \in \mathcal{PC}_{2\pi}(\mathbb{R})$  be given by

$$S_n(f)(x) = \frac{a_0}{2} + \sum_{k=1}^n (a_k \cos(kx) + b_k \sin(kx))$$

for  $x \in \mathbb{R}$ . Then  $S_n(f)$  is the unique trigonometric polynomial  $T_n$  of degree  $n$  for which  $\|f - T_n\|_2$  becomes minimal. In fact, we have

$$\|f - S_n(f)\|_2^2 = \|f\|_2^2 - \pi \left( \frac{a_0^2}{2} + \sum_{k=1}^n (a_k^2 + b_k^2) \right).$$

**Corollary 9.3.8** (Bessel's Inequality). Let  $f \in \mathcal{PC}_{2\pi}(\mathbb{R})$  have the Fourier coefficients  $a_0, a_1, a_2, \dots, b_1, b_2, \dots$ . Then we have the inequality

$$\frac{a_0^2}{2} + \sum_{n=1}^{\infty} (a_n^2 + b_n^2) \leq \frac{1}{\pi} \|f\|_2^2.$$

In particular,  $\lim_{n \rightarrow \infty} a_n = \lim_{n \rightarrow \infty} b_n = 0$ .

**Definition 9.3.9.** Let  $n \in \mathbb{N}_0$ . The  $n$ -th Dirichlet kernel is defined on  $[-\pi, \pi]$  by letting

$$D_n(t) := \begin{cases} \frac{\sin((n+\frac{1}{2})t)}{2 \sin(\frac{1}{2}t)}, & 0 < |t| \leq \pi, \\ n + \frac{1}{2}, & t = 0. \end{cases}$$

**Lemma 9.3.10.** Let  $f \in \mathcal{PC}_{2\pi}(\mathbb{R})$ . Then

$$S_n(f)(x) = \frac{1}{\pi} \int_{-\pi}^{\pi} f(x+t) D_n(t) dt$$

for all  $n \in \mathbb{N}_0$  and  $x \in [-\pi, \pi]$ .

*Proof.* Let  $n \in \mathbb{N}_0$  and let  $x \in [-\pi, \pi]$ . We have

$$\begin{aligned} S_n(f)(x) &= \frac{1}{2\pi} \int_{-\pi}^{\pi} f(t) dt + \frac{1}{\pi} \int_{-\pi}^{\pi} \sum_{k=1}^n f(t) (\cos(kt) \cos(kx) + \sin(kt) \sin(kx)) dt \\ &= \frac{1}{\pi} \int_{-\pi}^{\pi} f(t) \left( \frac{1}{2} + \sum_{k=1}^n \cos(kt - kx) \right) dt \\ &= \frac{1}{\pi} \int_{-\pi-x}^{\pi-x} f(x+s) \left( \frac{1}{2} + \sum_{k=1}^n \cos(ks) \right) ds \\ &= \frac{1}{\pi} \int_{-\pi}^{\pi} f(x+s) \left( \frac{1}{2} + \sum_{k=1}^n \cos(ks) \right) ds, \end{aligned}$$

where we have used the substitution  $s = t - x$ .

We now claim for all  $s \in [-\pi, \pi]$  that

$$D_n(s) = \frac{1}{2} + \sum_{k=1}^n \cos(ks).$$

If  $s = 0$ , the claim is seen to hold. Otherwise, note for any real  $s$  and  $k$  that

$$2 \cos(ks) \sin\left(\frac{1}{2}s\right) = \sin\left(\left(k + \frac{1}{2}\right)s\right) - \sin\left(\left(k - \frac{1}{2}\right)s\right).$$

On summing this identity from  $k = 1$  to  $n \in \mathbb{N}$  we obtain

$$\begin{aligned} 2 \sin\left(\frac{1}{2}s\right) \sum_{k=1}^n \cos(ks) &= \sum_{k=1}^n \left[ \sin\left(\left(k + \frac{1}{2}\right)s\right) - \sin\left(\left(k - \frac{1}{2}\right)s\right) \right] \\ &= \sin\left(\left(n + \frac{1}{2}\right)s\right) - \sin\left(\frac{1}{2}s\right) \end{aligned}$$

and thus, for  $s \in [-\pi, 0) \cup (0, \pi]$ ,

$$\sum_{k=1}^n \cos(ks) = \frac{\sin\left(\left(n + \frac{1}{2}\right)s\right) - \sin\left(\frac{1}{2}s\right)}{2 \sin\left(\frac{1}{2}s\right)} = D_n(s) - \frac{1}{2}.$$

□

**Lemma 9.3.11** (Riemann–Lebesgue Lemma). *For  $f \in \mathcal{PC}_{2\pi}(\mathbb{R})$ , we have that*

$$\lim_{n \rightarrow \infty} \int_{-\pi}^{\pi} f(t) \sin\left(\left(n + \frac{1}{2}\right)t\right) dt = 0.$$

*Proof.* Note that, for  $n \in \mathbb{N}$ , we have

$$\begin{aligned} &\int_{-\pi}^{\pi} f(t) \sin\left(\left(n + \frac{1}{2}\right)t\right) dt \\ &= \frac{1}{\pi} \int_{-\pi}^{\pi} \pi f(t) \sin\left(\frac{1}{2}t\right) \cos(nt) dt + \frac{1}{\pi} \int_{-\pi}^{\pi} \pi f(t) \cos\left(\frac{1}{2}t\right) \sin(nt) dt. \end{aligned}$$

Since both of these terms are Fourier coefficients, it follows from Bessel's Inequality that

$$\lim_{n \rightarrow \infty} \frac{1}{\pi} \int_{-\pi}^{\pi} \left( \pi f(t) \sin\left(\frac{1}{2}t\right) \right) \cos(nt) dt = \lim_{n \rightarrow \infty} \frac{1}{\pi} \int_{-\pi}^{\pi} \left( \pi f(t) \cos\left(\frac{1}{2}t\right) \right) \sin(nt) dt = 0.$$

This proves the claim. □

**Definition 9.3.12.** Let  $f: \mathbb{R} \rightarrow \mathbb{R}$ , and let  $x \in \mathbb{R}$ . We say that:

(a)  $f$  has a *right-hand derivative* at  $x$  if

$$\lim_{h \downarrow 0} \frac{f(x+h) - f(x^+)}{h}$$

exists, where  $f(x^+) := \lim_{h \downarrow 0} f(x+h)$  is supposed to exist.



(b)  $f$  has a *left-hand derivative* at  $x$  if

$$\lim_{h \uparrow 0} \frac{f(x+h) - f(x^-)}{h}$$

exists, where  $f(x^-) := \lim_{h \uparrow 0} f(x+h)$  is supposed to exist.

**Theorem 9.3.13.** *Let  $f \in \mathcal{PC}_{2\pi}(\mathbb{R})$  and suppose that  $f$  has left- and right-hand derivatives at  $x \in \mathbb{R}$ . Then*

$$\frac{a_0}{2} + \sum_{n=1}^{\infty} (a_n \cos(nx) + b_n \sin(nx)) = \frac{1}{2}(f(x^+) + f(x^-)).$$

*Proof.* In the proof of Lemma 9.3.10, we saw for  $t \in [-\pi, \pi]$  and  $n \in \mathbb{N}$  that

$$\frac{1}{2} + \sum_{k=1}^n \cos(kt) = D_n(t),$$

so that

$$\frac{1}{\pi} \int_0^{\pi} f(x^+) D_n(t) dt = \frac{1}{2} f(x^+) + \sum_{k=1}^n \frac{1}{\pi} f(x^+) \underbrace{\int_0^{\pi} \cos(kt) dt}_{=0} = \frac{1}{2} f(x^+)$$

and similarly

$$\frac{1}{\pi} \int_{-\pi}^0 f(x^-) D_n(t) dt = \frac{1}{2} f(x^-).$$

It follows for  $n \in \mathbb{N}$  that

$$\begin{aligned} S_n(f)(x) - \frac{1}{2}(f(x^+) + f(x^-)) &= \frac{1}{\pi} \int_{-\pi}^{\pi} f(x+t) D_n(t) dt - \frac{1}{\pi} \int_0^{\pi} f(x^+) D_n(t) dt - \frac{1}{\pi} \int_{-\pi}^0 f(x^-) D_n(t) dt \\ &= \frac{1}{\pi} \int_{-\pi}^0 \frac{f(x+t) - f(x^-)}{2 \sin(\frac{1}{2}t)} \sin\left(\left(n + \frac{1}{2}\right)t\right) dt \\ &\quad + \frac{1}{\pi} \int_0^{\pi} \frac{f(x+t) - f(x^+)}{2 \sin(\frac{1}{2}t)} \sin\left(\left(n + \frac{1}{2}\right)t\right) dt. \end{aligned}$$

Define  $g: (-\pi, \pi] \rightarrow \mathbb{R}$  by letting

$$g(t) := \begin{cases} 0, & t \in (-\pi, 0), \\ \frac{f(x+t) - f(x^+)}{2 \sin(\frac{1}{2}t)}, & t \in (0, \pi]. \end{cases}$$

Since

$$\lim_{t \downarrow 0} \frac{f(x+t) - f(x^+)}{2 \sin(\frac{1}{2}t)} = \lim_{t \downarrow 0} \frac{f(x+t) - f(x^+)}{t} \frac{\frac{1}{2}t}{\sin(\frac{1}{2}t)} = \lim_{t \downarrow 0} \frac{f(x+t) - f(x^+)}{t}$$

exists, it follows that  $g \in \mathcal{PC}_{2\pi}(\mathbb{R})$ . From the Riemann–Lebesgue Lemma, it follows that

$$\lim_{n \rightarrow \infty} \int_0^\pi \frac{f(x+t) - f(x^+)}{2 \sin(\frac{1}{2}t)} \sin\left(\left(n + \frac{1}{2}\right)t\right) dt = \lim_{n \rightarrow \infty} \int_{-\pi}^\pi g(t) \sin\left(\left(n + \frac{1}{2}\right)t\right) dt = 0$$

and, analogously,

$$\lim_{n \rightarrow \infty} \int_{-\pi}^0 \frac{f(x+t) - f(x^-)}{2 \sin(\frac{1}{2}t)} \sin\left(\left(n + \frac{1}{2}\right)t\right) dt = 0.$$

This completes the proof.  $\square$

*Example.* Let

$$f: (-\pi, \pi] \rightarrow \mathbb{R}, \quad x \mapsto \begin{cases} -1, & x \in (-\pi, 0), \\ 1, & x \in [0, \pi]. \end{cases}$$

It follows that

$$f(x) = \frac{4}{\pi} \sum_{n=0}^{\infty} \frac{1}{2n+1} \sin((2n+1)x)$$

for all  $x$  that are not integer multiples of  $\pi$ .

In the following definitions, being differentiable at the left- (right-) hand endpoint of a closed interval is understood as meaning that the right- (left-) hand derivative exists at that point. Given  $a < b$ , we call a function  $f: [a, b] \rightarrow \mathbb{R}$ :

- *piecewise differentiable* if there exists a partition  $a = t_0 < t_1 < \dots < t_n = b$  such that  $f|_{[t_{j-1}, t_j]}$  is differentiable for  $j = 1, \dots, n$ ;
- *piecewise continuously differentiable* if there exists a partition  $a = t_0 < t_1 < \dots < t_n = b$  such that  $f|_{[t_{j-1}, t_j]}$  is continuously differentiable for  $j = 1, \dots, n$ ;
- *piecewise linear* if there exists a partition  $a = t_0 < t_1 < \dots < t_n = b$  such that, for  $j = 1, \dots, n$ , the graph of  $f|_{[t_{j-1}, t_j]}$  is the line segment connecting  $(t_{j-1}, f(t_{j-1}))$  and  $(t_j, f(t_j))$ .

The following is immediate from Theorem 9.3.13:

**Corollary 9.3.14.** *Let  $f \in \mathcal{PC}_{2\pi}(\mathbb{R})$  be continuous and piecewise differentiable on  $[-\pi, \pi]$ . Then*

$$\frac{a_0}{2} + \sum_{n=1}^{\infty} (a_n \cos(nx) + b_n \sin(nx)) = f(x)$$

for all  $x \in \mathbb{R}$ .

**Theorem 9.3.15.** *Let  $f \in \mathcal{PC}_{2\pi}(\mathbb{R})$  be continuous and piecewise continuously differentiable on  $[-\pi, \pi]$ . Then*

$$\frac{a_0}{2} + \sum_{n=1}^{\infty} (a_n \cos(nx) + b_n \sin(nx)) \tag{9.7}$$

converges uniformly to  $f(x)$  on  $\mathbb{R}$ .

*Proof.* Let  $-\pi = t_0 < t_1 < \dots < t_m = \pi$  be such that  $f$  is continuously differentiable on  $[t_{j-1}, t_j]$  for  $j = 1, \dots, m$ . Then  $f'(t)$  exists for  $t \in [-\pi, \pi]$ —except possibly at  $t \in \{t_0, \dots, t_m\}$ —and thus gives rise to a function in  $\mathcal{PC}_{2\pi}(\mathbb{R})$ , which we shall denote by  $f'$  for the sake of simplicity.

Let  $a'_0, a'_1, a'_2, \dots, b'_1, b'_2, \dots$  be the Fourier coefficients of  $f'$ . For  $n \in \mathbb{N}$ ,

$$\begin{aligned} a'_n &= \frac{1}{\pi} \int_{-\pi}^{\pi} f'(t) \cos(nt) dt \\ &= \frac{1}{\pi} \sum_{j=1}^m \int_{t_{j-1}}^{t_j} f'(t) \cos(nt) dt \\ &= \frac{1}{\pi} \sum_{j=1}^m \left( f(t) \cos(nt) \Big|_{t_{j-1}}^{t_j} + n \int_{t_{j-1}}^{t_j} f(t) \sin(nt) dt \right) \\ &= \frac{n}{\pi} \int_{-\pi}^{\pi} f(t) \sin(nt) dt \\ &= nb_n \end{aligned}$$

and, in a similar vein,

$$b'_n = -na_n.$$

From Bessel's Inequality, we know that  $\sum_{n=1}^{\infty} (b'_n)^2 < \infty$ , and from the Cauchy–Schwarz Inequality, we conclude that

$$\sum_{n=1}^{\infty} |a_n| = \sum_{n=1}^{\infty} \frac{1}{n} |b'_n| \leq \left( \sum_{n=1}^{\infty} \frac{1}{n^2} \right)^{\frac{1}{2}} \left( \sum_{n=1}^{\infty} (b'_n)^2 \right)^{\frac{1}{2}} < \infty;$$

analogously, we see that  $\sum_{n=1}^{\infty} |b_n| < \infty$  as well.

Since

$$|a_n \cos(nx) + b_n \sin(nx)| \leq |a_n| + |b_n|$$

for all  $x \in \mathbb{R}$ , the Weierstraß  $M$ -Test yields that the Fourier series  $\frac{a_0}{2} + \sum_{n=1}^{\infty} (a_n \cos(nx) + b_n \sin(nx))$  converges uniformly on  $\mathbb{R}$ . Since the identity (9.7) holds pointwise by Corollary 9.3.14, the uniform limit of the Fourier series must be  $f$ .  $\square$

*Example.* Let  $f \in \mathcal{PC}_{2\pi}(\mathbb{R})$  be given by  $f(x) := x^2$  for  $x \in (-\pi, \pi]$ . It is easy to see that  $b_n = 0$  for all  $n \in \mathbb{N}$ .

We have

$$a_0 = \frac{1}{\pi} \int_{-\pi}^{\pi} t^2 dt = \frac{1}{\pi} \left( \frac{t^3}{3} \Big|_{-\pi}^{\pi} \right) = \frac{1}{\pi} \left( \frac{\pi^3}{3} + \frac{\pi^3}{3} \right) = \frac{2\pi^2}{3}.$$

For  $n \in \mathbb{N}$ , we compute

$$\begin{aligned}
 a_n &= \frac{1}{\pi} \int_{-\pi}^{\pi} t^2 \cos(nt) dt \\
 &= \frac{1}{\pi} \left( \frac{t^2}{n} \sin(nt) \Big|_{-\pi}^{\pi} - \frac{2}{n} \int_{-\pi}^{\pi} t \sin(nt) dt \right) \\
 &= -\frac{2}{\pi n} \int_{-\pi}^{\pi} t \sin(nt) dt \\
 &= -\frac{2}{\pi n} \left( -\frac{t}{n} \cos(nt) \Big|_{-\pi}^{\pi} + \frac{1}{n} \int_{-\pi}^{\pi} \cos(nt) dt \right) \\
 &= \frac{4}{n^2} \cos(\pi n) \\
 &= (-1)^n \frac{4}{n^2}.
 \end{aligned}$$

Hence, we have the identity

$$f(x) = \frac{\pi^2}{3} + \sum_{n=1}^{\infty} (-1)^n \frac{4}{n^2} \cos(nx),$$

where the convergence is uniform on  $\mathbb{R}$ .

Letting  $x = 0$ , we obtain

$$0 = \frac{\pi^2}{3} + \sum_{n=1}^{\infty} (-1)^n \frac{4}{n^2},$$

so that

$$\frac{\pi^2}{12} = \sum_{n=1}^{\infty} \frac{(-1)^{n-1}}{n^2}.$$

Letting  $x = \pi$  yields

$$\pi^2 = \frac{\pi^2}{3} + \sum_{n=1}^{\infty} (-1)^n \frac{4}{n^2} (-1)^n = \frac{\pi^2}{3} + \sum_{n=1}^{\infty} \frac{4}{n^2}$$

and thus

$$\sum_{n=1}^{\infty} \frac{1}{n^2} = \frac{\pi^2}{6}.$$

For our last two theorems, we require the following lemma:

**Lemma 9.3.16.** *Let  $a < b$ ,  $f : [a, b] \rightarrow \mathbb{R}$  be continuous, and  $\epsilon > 0$ . Then there exists a continuous, piecewise linear function  $g : [a, b] \rightarrow \mathbb{R}$  such that  $g(a) = f(a)$ ,  $g(b) = f(b)$ , and  $|f(t) - g(t)| < \epsilon$  for all  $t \in [a, b]$ .*

*Proof.* As  $[a, b]$  is compact and  $f$  is continuous,  $f$  is uniformly continuous. Choose  $\delta > 0$  such that  $|f(s) - f(t)| < \frac{\epsilon}{2}$  for  $s, t \in [a, b]$  with  $|s - t| < \delta$ . Let  $a = t_0 < t_1 < \dots < t_n = b$

be a partition of  $[a, b]$  with  $\max_{j=1, \dots, n} |t_j - t_{j-1}| < \delta$ . Define  $g : [a, b] \rightarrow \mathbb{R}$  as follows: if  $t \in [t_{j-1}, t_j]$  with  $j \in \{1, \dots, n\}$ , let

$$g(t) := \frac{1}{t_j - t_{j-1}}((t_j - t)f(t_{j-1}) + (t - t_{j-1})f(t_j)).$$

Then  $g$  is a piecewise linear, continuous function with  $g(t_j) = f(t_j)$  for  $j = 0, 1, \dots, n$ . Let  $t \in [a, b]$ , and let  $j \in \{1, \dots, n\}$  be such that  $t \in [t_{j-1}, t_j]$ . We obtain

$$\begin{aligned} |f(t) - g(t)| &= \left| \frac{1}{t_j - t_{j-1}}((t_j - t)f(t) + (t - t_{j-1})f(t)) \right. \\ &\quad \left. - \frac{1}{t_j - t_{j-1}}((t_j - t)f(t_{j-1}) + (t - t_{j-1})f(t_j)) \right| \\ &\leq \frac{1}{t_j - t_{j-1}}((t_j - t)|f(t) - f(t_{j-1})| + (t - t_{j-1})|f(t) - f(t_j)|) \\ &\leq \underbrace{|f(t) - f(t_{j-1})|}_{< \frac{\epsilon}{2}} + \underbrace{|f(t) - f(t_j)|}_{< \frac{\epsilon}{2}} \\ &< \epsilon. \end{aligned}$$

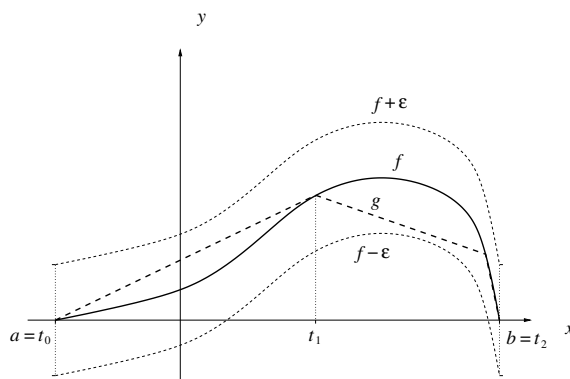

Figure 9.2: The functions  $f$  and  $g$

This proves the claim.  $\square$

**Theorem 9.3.17** (Weierstraß' Approximation Theorem). *Let  $a < b$ ,  $f : [a, b] \rightarrow \mathbb{R}$  be continuous, and  $\epsilon > 0$ . Then there exists a polynomial  $p$  such that  $|f(t) - p(t)| < \epsilon$  for  $t \in [a, b]$ . In particular, there exists a sequence of polynomials that converges to  $f$  uniformly on  $[a, b]$ .*

*Proof.* Without loss of generality let  $a = -\pi$  and  $b = \pi$ .

Consider first the case where  $f(-\pi) = f(\pi) = 0$ . We can then extend  $f$  to a continuous function in  $\mathcal{PC}_{2\pi}(\mathbb{R})$  (likewise denoted by  $f$ ). By Lemma 9.3.16, there exists a continuous,

piecewise linear function  $g: [-\pi, \pi] \rightarrow \mathbb{R}$  such that  $g(-\pi) = g(\pi) = 0$  and  $|f(t) - g(t)| < \frac{\epsilon}{3}$  for  $t \in [-\pi, \pi]$ . Extend  $g$  to a function in  $\mathcal{PC}_{2\pi}(\mathbb{R})$  (also denoted by  $g$ ). As  $g$  is, in particular, piecewise continuously differentiable, Theorem 9.3.15 yields  $n_\epsilon \in \mathbb{N}$  such that  $|g(t) - S_n(g)(t)| < \frac{\epsilon}{3}$  for all  $n \geq n_\epsilon$  and all  $t \in [-\pi, \pi]$ . For  $k = 1, \dots, n_\epsilon$ , the Taylor series of  $\cos(kt)$  and  $\sin(kt)$  converge uniformly to those functions on  $[-\pi, \pi]$ . Truncating these series after sufficiently many terms, we obtain a polynomial  $p$  with  $|S_{n_\epsilon}(g)(t) - p(t)| < \frac{\epsilon}{3}$  for all  $t \in [-\pi, \pi]$ . Consequently,

$$|f(t) - p(t)| \leq \underbrace{|f(t) - g(t)|}_{< \frac{\epsilon}{3}} + \underbrace{|g(t) - S_{n_\epsilon}(g)(t)|}_{< \frac{\epsilon}{3}} + \underbrace{|S_{n_\epsilon}(g)(t) - p(t)|}_{< \frac{\epsilon}{3}} < \epsilon$$

for all  $t \in [-\pi, \pi]$ .

Suppose now that  $f$  is arbitrary. Define

$$h: [-\pi, \pi] \rightarrow \mathbb{R}, \quad t \mapsto f(t) - \frac{1}{2\pi}((\pi - t)f(-\pi) + (t + \pi)f(\pi)).$$

Then  $h$  is continuous with  $h(-\pi) = h(\pi) = 0$ . By the first part of the proof, there exists a polynomial  $q$  such that  $|h(t) - q(t)| < \epsilon$  for  $t \in [-\pi, \pi]$ . Let

$$p(t) := \frac{1}{2\pi}((\pi - t)f(-\pi) + (t + \pi)f(\pi)) + q(t)$$

for  $t \in \mathbb{R}$ . Then  $p$  is a polynomial such that  $|f(t) - p(t)| = |h(t) - q(t)| < \epsilon$  for  $t \in [-\pi, \pi]$ .  $\square$

**Theorem 9.3.18.** *Let  $f \in \mathcal{PC}_{2\pi}(\mathbb{R})$ . Then  $\lim_{n \rightarrow \infty} \|f - S_n(f)\|_2 \rightarrow 0$ .*

*Proof.* Let  $\epsilon > 0$ , and choose a partition  $-\pi = t_0 < t_1 < \dots < t_m = \pi$  such that  $f$  is continuous on  $(t_{j-1}, t_j)$  for  $j = 1, \dots, m$ . Choose  $\delta > 0$  so small that the intervals

$$[-\pi, t_0 + \delta], [t_1 - \delta, t_1 + \delta], \dots, [t_{m-1} - \delta, t_{m-1} + \delta], [t_m - \delta, \pi] \quad (9.8)$$

are pairwise disjoint. Define  $g: [-\pi, \pi] \rightarrow \mathbb{R}$  as follows:

- $g(-\pi) = g(\pi) = 0$ ;
- $g(t) = f(t)$  for all  $t$  in the complement of  $[-\pi, t_0 + \delta] \cup (t_1 - \delta, t_1 + \delta) \cup \dots \cup (t_{m-1} - \delta, t_{m-1} + \delta) \cup (t_m - \delta, \pi]$ ;
- $g$  linearly connects its values at the endpoints of the intervals (9.8) on those intervals.

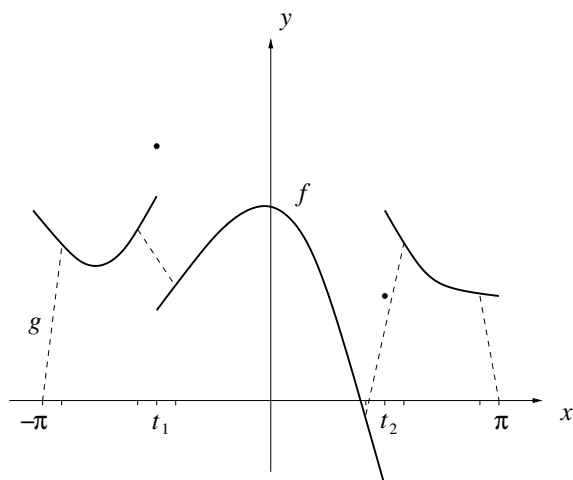
Figure 9.3: The functions  $f$  and  $g$ 

Let  $C \geq 0$  be such that  $|f(t)| \leq C$  for  $t \in [-\pi, \pi]$ . Then  $g$  is continuous such that  $|g(t)| \leq C$  for  $t \in [-\pi, \pi]$  as well and extends to a continuous function in  $\mathcal{PC}_{2\pi}(\mathbb{R})$ , which is likewise denoted by  $g$ .

We have

$$\begin{aligned}
 & \|f - g\|_2^2 \\
 &= \int_{-\pi}^{\pi} |f(t) - g(t)|^2 dt \\
 &= \int_{-\pi}^{t_0+\delta} \underbrace{|f(t) - g(t)|^2}_{\leq 4C^2} dt + \sum_{j=1}^{m-1} \int_{t_{j-\delta}}^{t_j+\delta} \underbrace{|f(t) - g(t)|^2}_{\leq 4C^2} dt + \int_{t_{m-\delta}}^{\pi} \underbrace{|f(t) - g(t)|^2}_{\leq 4C^2} dt \\
 &\leq \delta 4C^2 + (m-1)\delta 8C^2 + \delta 4C^2 \\
 &= m\delta 8C^2.
 \end{aligned}$$

Making  $\delta > 0$  small enough, we can thus suppose that  $\|f - g\|_2 < \frac{\epsilon}{7}$ .

Invoking Lemma 9.3.16, there exists a continuous, piecewise linear function  $h: [-\pi, \pi] \rightarrow \mathbb{R}$  such that

$$|g(t) - h(t)| < \frac{\epsilon}{7}$$

for  $t \in [-\pi, \pi]$  and  $h(-\pi) = h(\pi) = 0$ . By Theorem 9.3.15, there exists  $n_\epsilon \in \mathbb{N}$  such that

$$|h(t) - S_{n_\epsilon}(h)(t)| < \frac{\epsilon}{7}$$

for  $n \geq n_\epsilon$  and  $t \in \mathbb{R}$ . For  $n \geq n_\epsilon$ , we thus obtain

$$\begin{aligned} \|f - S_n(h)\|_2 &\leq \|f - g\|_2 + \|g - h\|_2 + \|h - S_n(h)\|_2 \\ &< \frac{\epsilon}{7} + \sqrt{2\pi} \sup\{|g(t) - h(t)| : t \in [-\pi, \pi]\} \\ &\quad + \sqrt{2\pi} \sup\{|h(t) - S_n(h)(t)| : t \in [-\pi, \pi]\} \\ &< \frac{\epsilon}{7} + 3\frac{\epsilon}{7} + 3\frac{\epsilon}{7} \\ &= \epsilon. \end{aligned}$$

Since  $S_n(h)$  is a trigonometric polynomial of degree  $n$ , we obtain from Proposition 9.3.7 that

$$\|f - S_n(f)\|_2 \leq \|f - S_n(h)\|_2 < \epsilon$$

for  $n \geq n_\epsilon$ . □

**Corollary 9.3.19** (Parseval's Identity). *Let  $f \in \mathcal{PC}_{2\pi}(\mathbb{R})$  have the Fourier coefficients  $a_0, a_1, a_2, \dots, b_1, b_2, \dots$ . Then*

$$\frac{a_0^2}{2} + \sum_{n=1}^{\infty} (a_n^2 + b_n^2) = \frac{1}{\pi} \|f\|_2^2.$$

### Exercises

1. Let  $f \in \mathcal{PC}_{2\pi}(\mathbb{R})$  have the Fourier coefficients  $a_0, a_1, a_2, \dots, b_1, b_2, \dots$ . Show that  $a_0 = a_1 = a_2 = \dots = 0$  if  $f$  is odd and  $b_1 = b_2 = \dots = 0$  if  $f$  is even.
2. For  $n \in \mathbb{Z}$ , the  $n$ -th complex Fourier coefficient of  $f \in \mathcal{PC}_{2\pi}(\mathbb{R})$  is defined as

$$c_n := \frac{1}{2\pi} \int_{-\pi}^{\pi} f(t) e^{-int} dt.$$

Express the complex Fourier coefficients of  $f$  in terms of its real Fourier coefficients  $a_0, a_1, a_2, \dots$  and  $b_1, b_2, \dots$ .

3. Let  $f \in \mathcal{PC}_{2\pi}(\mathbb{R})$ , and let  $F : \mathbb{R} \rightarrow \mathbb{R}$  be an antiderivative of  $f$ . Show that  $F \in \mathcal{PC}_{2\pi}(\mathbb{R})$  if and only if

$$\int_{-\pi}^{\pi} f(t) dt = 0.$$

4. Let  $f \in \mathcal{PC}_{2\pi}(\mathbb{R})$  be given by

$$f : (-\pi, \pi] \rightarrow \mathbb{R}, \quad x \mapsto x.$$

Determine the Fourier series  $\frac{a_0}{2} + \sum_{n=1}^{\infty} (a_n \cos(nx) + b_n \sin(nx))$  of  $f$ .



5. Let  $f \in \mathcal{PC}_{2\pi}(\mathbb{R})$  be given by

$$f(t) := \begin{cases} -1, & t \in (-\pi, 0), \\ 1, & t \in (0, \pi] \end{cases}$$

for  $t \in (-\pi, \pi]$ . Show that the Fourier series of  $f$  converges pointwise on  $\mathbb{R}$ , but not uniformly.

6. Let  $f \in \mathcal{PC}_{2\pi}(\mathbb{R})$  be given by

$$f: (-\pi, \pi] \rightarrow \mathbb{R}, \quad x \mapsto |x|.$$

Determine the Fourier series of  $f$  and argue that it converges to  $f$  uniformly on  $\mathbb{R}$ . Conclude that

$$\frac{\pi^2}{8} = \sum_{n=0}^{\infty} \frac{1}{(2n+1)^2}.$$

7. Let  $f, F \in \mathcal{PC}_{2\pi}(\mathbb{R})$ , let  $a_0, a_1, a_2, \dots, b_1, b_2, \dots$  be the Fourier coefficients of  $f$ , and let  $A_0, A_1, A_2, \dots, B_1, B_2, \dots$  be the Fourier coefficients of  $F$ . Show that

$$\frac{1}{\pi} \int_{-\pi}^{\pi} f(t)F(t) dt = \frac{a_0A_0}{2} + \sum_{n=1}^{\infty} (a_nA_n + b_nB_n).$$

(Hint: Apply Parseval's Identity to  $f + F$ .)

8. Let  $a < b$ , let  $f: [a, b] \rightarrow \mathbb{R}$  be continuous, let  $a \leq t_1 < t_2 < \dots < t_n \leq b$ , and let  $\epsilon > 0$ . Show that there exists a polynomial  $p$  with  $|f(t) - p(t)| < \epsilon$  for  $t \in [a, b]$  and  $p(t_j) = f(t_j)$  for  $j = 1, \dots, n$ . (Hint: First, treat the case where  $f(t_1) = \dots = f(t_n) = 0$ , then apply this to the auxiliary function  $[a, b] \ni t \mapsto f(t) - \sum_{k=1}^n f(t_k) \prod_{\substack{j=1 \\ j \neq k}}^n \frac{t-t_j}{t_k-t_j}$ .)

## 9.4 Uniform Convergence of Improper Integrals

Let  $\emptyset \neq D \subset \mathbb{R}^N$  and  $f: D \times [0, \infty) \rightarrow \mathbb{R}$ ,  $(x, t) \mapsto f(x, t)$  be continuous. How do we test for uniform convergence of

$$\int_0^{\infty} f(x, t) dt = \lim_{T \rightarrow \infty} \int_0^T f(x, t) dt?$$

We can't use Corollary 9.1.4 here since we are taking the limit of the integration domain, not the integrand. Instead, we will use a uniform Cauchy Criterion for improper integrals:

**Theorem 9.4.1.** *Let  $\emptyset \neq D \subset \mathbb{R}^N$  and  $f: D \times [0, \infty) \rightarrow \mathbb{R}$ ,  $(x, t) \mapsto f(x, t)$  be continuous. Then  $\int_0^{\infty} f(x, t) dt$  converges uniformly on  $D$  iff for each  $\epsilon > 0$ , there exists  $T$  such that  $\left| \int_{T_1}^{T_2} f(x, t) dt \right| < \epsilon$  for all  $x \in D$  and all  $T_1, T_2 \geq T$ .*

We now formulate improper integral versions of Theorems 9.1.3, 9.1.4, 9.1.5, and 9.1.8:

**Theorem 9.4.2.** Let  $\emptyset \neq D \subset \mathbb{R}^N$  and  $f : D \times [0, \infty) \rightarrow \mathbb{R}$ ,  $(x, t) \mapsto f(x, t)$  be continuous such that  $\int_0^\infty f(x, t) dt$  is uniformly convergent on  $D$ . Then  $x \mapsto \int_0^\infty f(x, t) dt$  is continuous on  $D$ .

*Proof.* Apply Theorem 9.1.3 to the sequence of continuous functions

$$\left\{ x \mapsto \int_0^n f(x, t) dt \right\}_{n=1}^\infty.$$

□

**Theorem 9.4.3.** Let  $\emptyset \neq D \subset \mathbb{R}^N$  have content, and let  $f : D \times [0, \infty) \rightarrow \mathbb{R}$ ,  $(x, t) \mapsto f(x, t)$  be continuous such that  $\int_0^\infty f(x, t) dt$  is uniformly convergent on  $D$ . Then

$$\int_D \int_0^\infty f(x, t) dt = \int_0^\infty \int_D f(x, t) dt.$$

*Proof.* Apply Theorem 9.1.4 to the sequence of continuous functions

$$\left\{ x \mapsto \int_0^n f(x, t) dt \right\}_{n=1}^\infty$$

and use Fubini's theorem. □

**Theorem 9.4.4.** Let  $a < b$  and  $f : [a, b] \times [0, \infty) \rightarrow \mathbb{R}$ ,  $(x, t) \mapsto f(x, t)$  be continuous such that  $\frac{\partial f}{\partial x}$  exists and is continuous on  $[a, b] \times [0, \infty)$ . Suppose that

(a)  $\int_0^\infty f(x_0, t) dt$  converges at some  $x_0 \in [a, b]$ ;

(b)  $\int_0^\infty \frac{\partial f}{\partial x}(x, t) dt$  is uniformly convergent on  $[a, b]$ .

Then  $\int_0^\infty f(x, t) dt$  converges uniformly on  $[a, b]$ , with

$$\frac{d}{dx} \int_0^\infty f(x, t) dt = \int_0^\infty \frac{\partial f}{\partial x}(x, t) dt$$

for all  $x \in [a, b]$ .

*Proof.* Apply Theorem 9.1.5 to the sequence of continuous functions

$$\left\{ x \mapsto \int_0^n f(x, t) dt \right\}_{n=1}^\infty.$$

□

**Theorem 9.4.5** (Weierstraß  $M$ -Test). *Let  $\emptyset \neq D \subset \mathbb{R}^N$  and  $f : D \times [0, \infty) \rightarrow \mathbb{R}$ . If for every  $x \in D$ ,  $t \mapsto f(x, t)$  is Riemann integrable over compact subintervals of  $[0, \infty)$  and  $|f(x, t)| \leq M(t)$  for all  $x \in D$  and  $t \in [0, \infty)$ , such that  $\int_0^\infty M(t) dt$  converges, then  $\int_0^\infty f(x, t) dt$  is absolutely and uniformly convergent on  $D$ .*

*Proof.* For any non-negative numbers  $T_2 > T_1$ ,

$$\left| \int_{T_1}^{T_2} f(x, t) dt \right| \leq \int_{T_1}^{T_2} |f(x, t)| dt \leq \int_{T_1}^{T_2} M(t) dt.$$

Apply the Cauchy Criterion, Theorem 9.4.1. □

# Appendix A

## Linear Algebra

### A.1 Linear Maps and Matrices

**Definition A.1.1.** A map  $T: \mathbb{R}^N \rightarrow \mathbb{R}^M$  is called *linear* if

$$T(\lambda x + \mu y) = \lambda T(x) + \mu T(y)$$

holds for all  $x, y \in \mathbb{R}^N$  and  $\lambda, \mu \in \mathbb{R}$ .

*Example.* Let  $A$  be an  $M \times N$ -matrix, i.e.,

$$A = \begin{bmatrix} a_{1,1} & \cdots & a_{1,N} \\ \vdots & \ddots & \vdots \\ a_{M,1} & \cdots & a_{M,N} \end{bmatrix}.$$

Then we obtain a linear map  $T_A: \mathbb{R}^N \rightarrow \mathbb{R}^M$  by letting  $T_A(x) = Ax$  for  $x \in \mathbb{R}^N$ , i.e., for  $x = (x_1, \dots, x_N)$ , we have

$$T_A(x) = Ax = \begin{bmatrix} a_{1,1}x_1 + \cdots + a_{1,N}x_N \\ \vdots \\ a_{M,1}x_1 + \cdots + a_{M,N}x_N \end{bmatrix}.$$

**Theorem A.1.2.** *The following are equivalent for a map  $T: \mathbb{R}^N \rightarrow \mathbb{R}^M$ :*

- (i)  $T$  is linear;
- (ii) there is a (necessarily unique)  $M \times N$  matrix  $A$  such that  $T = T_A$ .

*Proof.* (ii)  $\implies$  (i) follows in view of the above example.

(i)  $\implies$  (ii): For  $j = 1, \dots, N$  let  $\mathbf{e}_j$  be the  $j$ -th canonical basis vector of  $\mathbb{R}^N$ , i.e.,

$$\mathbf{e}_j := (0, \dots, 0, 1, 0, \dots, 0),$$

where the 1 stands in the  $j$ -th coordinate. For  $j = 1, \dots, N$ , there are  $a_{1,j}, \dots, a_{M,j} \in \mathbb{R}$  such that

$$T(\mathbf{e}_j) = \begin{bmatrix} a_{1,j} \\ \vdots \\ a_{M,j} \end{bmatrix}.$$

Let

$$A := \begin{bmatrix} a_{1,1} & \cdots & a_{1,N} \\ \vdots & \ddots & \vdots \\ a_{M,1} & \cdots & a_{M,N} \end{bmatrix}.$$

In order to see that  $T_A = T$ , let  $x = (x_1, \dots, x_N) \in \mathbb{R}^N$ . Then we obtain

$$\begin{aligned} T(x) &= T(x_1\mathbf{e}_1 + \cdots + x_N\mathbf{e}_N) \\ &= x_1T(\mathbf{e}_1) + \cdots + x_NT(\mathbf{e}_N) \\ &= x_1 \begin{bmatrix} a_{1,1} \\ \vdots \\ a_{M,1} \end{bmatrix} + \cdots + x_N \begin{bmatrix} a_{1,N} \\ \vdots \\ a_{M,N} \end{bmatrix} \\ &= \begin{bmatrix} a_{1,1}x_1 + \cdots + a_{1,N}x_N \\ \vdots \\ a_{M,1}x_1 + \cdots + a_{M,N}x_N \end{bmatrix} \\ &= Ax. \end{aligned}$$

This completes the proof.  $\square$

**Corollary A.1.3.** *Let  $T: \mathbb{R}^N \rightarrow \mathbb{R}^M$  be linear. Then  $T$  is continuous.*

We will henceforth not strictly distinguish anymore between linear maps and their matrix representations.

**Lemma A.1.4.** *Let  $A: \mathbb{R}^N \rightarrow \mathbb{R}^M$  be a linear map. Then  $\{\|Ax\| : x \in \mathbb{R}^N, \|x\| \leq 1\}$  is bounded.*

*Proof.* Assume otherwise. Then, for each  $n \in \mathbb{N}$ , there is  $x_n \in \mathbb{R}^N$  such that  $\|x_n\| \leq 1$  such that  $\|Ax_n\| \geq n$ . Let  $y_n := \frac{x_n}{n}$ , so that  $y_n \rightarrow 0$ . However,

$$\|Ay_n\| = \frac{1}{n}\|Ax_n\| \geq \frac{1}{n}n = 1$$

holds for all  $n \in \mathbb{N}$ , so that  $Ay_n \not\rightarrow 0$ . This contradicts the continuity of  $A$ .  $\square$

**Definition A.1.5.** Let  $A: \mathbb{R}^N \rightarrow \mathbb{R}^M$  be a linear map. Then the *operator norm* of  $A$  is defined as

$$\|A\| := \sup\{\|Ax\| : x \in \mathbb{R}^N, \|x\| \leq 1\}.$$

**Theorem A.1.6.** Let  $A, B: \mathbb{R}^N \rightarrow \mathbb{R}^M$  and  $C: \mathbb{R}^M \rightarrow \mathbb{R}^K$  be linear maps, and let  $\lambda \in \mathbb{R}$ . Then the following are true:

- (i)  $\|A\| = 0 \iff A = 0$ ;
- (ii)  $\|\lambda A\| = |\lambda| \|A\|$ ;
- (iii)  $\|A + B\| \leq \|A\| + \|B\|$ ;
- (iv)  $\|CA\| \leq \|C\| \|A\|$ ;
- (v)  $\|A\|$  is the smallest number  $\gamma \geq 0$  such that  $\|Ax\| \leq \gamma \|x\|$  for all  $x \in \mathbb{R}^N$ .

*Proof.* (i) and (ii) are straightforward.

(iii): Let  $x \in \mathbb{R}^N$  such that  $\|x\| \leq 1$ . Then we have

$$\|(A + B)x\| \leq \|Ax\| + \|Bx\| \leq \|A\| + \|B\|$$

and consequently

$$\|A + B\| = \sup\{\|(A + B)x\| : x \in \mathbb{R}^N, \|x\| \leq 1\} \leq \|A\| + \|B\|.$$

We prove (v) before (iv): Let  $x \in \mathbb{R}^N \setminus \{0\}$ . Then

$$\left\| A \left( \frac{x}{\|x\|} \right) \right\| \leq \|A\|$$

holds, so that  $\|Ax\| \leq \|A\| \|x\|$ . Let  $\gamma \geq 0$  be any number such that  $\|Ax\| \leq \gamma \|x\|$  for all  $x \in \mathbb{R}^N$ . Then

$$\|A\| = \sup\{\|Ax\| : x \in \mathbb{R}^N, \|x\| \leq 1\} \leq \sup\{\gamma \|x\| : x \in \mathbb{R}^N, \|x\| \leq 1\} = \gamma.$$

This completes the proof.

(iv): Let  $x \in \mathbb{R}^N$ , then applying (v) twice yields

$$\|CAx\| \leq \|C\| \|Ax\| \leq \|C\| \|A\| \|x\|,$$

so that  $\|CA\| \leq \|C\| \|A\|$ , by (v) again.  $\square$

**Corollary A.1.7.** Let  $A: \mathbb{R}^N \rightarrow \mathbb{R}^M$  be a linear map. Then  $A$  is uniformly continuous.

*Proof.* Let  $\epsilon > 0$ , and let  $x, y \in \mathbb{R}^N$ . Then we have

$$\|Ax - Ay\| = \|A(x - y)\| \leq \|A\| \|x - y\|.$$

Let  $\delta := \frac{\epsilon}{\|A\| + 1}$ .  $\square$

## A.2 Determinants

There is some interdependence between this section and the following one (on eigenvalues).

For  $N \in \mathbb{N}$ , let  $\mathfrak{S}_N$  denote the *permutations* of  $\{1, \dots, N\}$ , i.e., the bijective maps from  $\{1, \dots, N\}$  into itself. There are  $N!$  such permutations. The *sign*  $\text{sgn } \sigma$  of a permutation  $\sigma \in \mathfrak{S}_N$  is  $-1$  to the number of times  $\sigma$  reverses the order in  $\{1, \dots, N\}$ , i.e.,

$$\text{sgn } \sigma := \prod_{1 \leq j < k \leq N} \frac{\sigma(k) - \sigma(j)}{k - j}.$$

**Definition A.2.1.** The *determinant* of an  $N \times N$ -matrix

$$A = \begin{bmatrix} a_{1,1} & \dots & a_{1,N} \\ \vdots & \ddots & \vdots \\ a_{N,1} & \dots & a_{N,N} \end{bmatrix} \quad (\text{A.1})$$

with entries from  $\mathbb{C}$  is defined as

$$\det A := \sum_{\sigma \in \mathfrak{S}_N} \text{sgn } \sigma a_{1,\sigma(1)} \cdots a_{N,\sigma(N)}. \quad (\text{A.2})$$

*Example.*

$$\det \begin{bmatrix} a & b \\ c & d \end{bmatrix} = ad - bc.$$

To actually compute the determinant of larger matrices, the formula (A.2) is of little use. However, it allows some insight into the properties of the determinant:

(A) if we multiply one column of a matrix  $A$  with a scalar  $\lambda$ , then the determinant of that new matrix is  $\lambda \det A$ , i.e.,

$$\begin{aligned} \det \begin{bmatrix} a_{1,1} & \dots & \lambda a_{1,j} & \dots & a_{1,N} \\ \vdots & \ddots & \vdots & \ddots & \vdots \\ a_{N,1} & \dots & \lambda a_{N,j} & \dots & a_{N,N} \end{bmatrix} \\ = \lambda \det \begin{bmatrix} a_{1,1} & \dots & a_{1,j} & \dots & a_{1,N} \\ \vdots & \ddots & \vdots & \ddots & \vdots \\ a_{N,1} & \dots & a_{N,j} & \dots & a_{N,N} \end{bmatrix}; \end{aligned}$$

(B) the determinant respects addition in a fixed column, i.e.,

$$\begin{aligned} \det \begin{bmatrix} a_{1,1} & \cdots & a_{1,j} + b_{1,j} & \cdots & a_{1,N} \\ \vdots & \ddots & \vdots & \ddots & \vdots \\ a_{N,1} & \cdots & a_{N,j} + b_{N,j} & \cdots & a_{N,N} \end{bmatrix} \\ = \det \begin{bmatrix} a_{1,1} & \cdots & a_{1,j} & \cdots & a_{1,N} \\ \vdots & \ddots & \vdots & \ddots & \vdots \\ a_{N,1} & \cdots & a_{N,j} & \cdots & a_{N,N} \end{bmatrix} + \\ \det \begin{bmatrix} a_{1,1} & \cdots & b_{1,j} & \cdots & a_{1,N} \\ \vdots & \ddots & \vdots & \ddots & \vdots \\ a_{N,1} & \cdots & b_{N,j} & \cdots & a_{N,N} \end{bmatrix}; \end{aligned}$$

(C) switching two columns of a matrix changes the sign of the determinant, i.e., for  $j < k$ ,

$$\begin{aligned} \det \begin{bmatrix} a_{1,1} & \cdots & a_{1,j} & \cdots & a_{1,k} & \cdots & a_{1,N} \\ \vdots & \ddots & \vdots & \ddots & \vdots & \ddots & \vdots \\ a_{N,1} & \cdots & a_{N,j} & \cdots & a_{N,k} & \cdots & a_{N,N} \end{bmatrix} \\ = -\det \begin{bmatrix} a_{1,1} & \cdots & a_{1,k} & \cdots & a_{1,j} & \cdots & a_{1,N} \\ \vdots & \ddots & \vdots & \ddots & \vdots & \ddots & \vdots \\ a_{N,1} & \cdots & a_{N,k} & \cdots & a_{N,j} & \cdots & a_{N,N} \end{bmatrix}; \end{aligned}$$

(D)  $\det I_N = 1$ .

These properties have several consequences:

- If a matrix has two identical columns, its determinant is zero (by (C)).
- More generally, if the columns of a matrix are linearly dependent, the matrix's determinant is zero (by (A), (B), and (C)).
- Adding one column to another one, does not change the value of the determinant (by (B) and (D)).

More importantly, properties (A), (B), (C), and (D), characterize the determinant:

**Theorem A.2.2.** *The determinant is the only map from  $M_N(\mathbb{C})$  to  $\mathbb{C}$  such that (A), (B), (C), and (D) hold.*

Given a square matrix as in (A.1), its *transpose* is defined as

$$A^t = \begin{bmatrix} a_{1,1} & \cdots & a_{N,1} \\ \vdots & \ddots & \vdots \\ a_{1,N} & \cdots & a_{N,N} \end{bmatrix}.$$

We have:



**Corollary A.2.3.** *Let  $A$  be an  $N \times N$ -matrix. Then  $\det A = \det A^t$  holds.*

*Proof.* The map

$$M_N(\mathbb{C}) \rightarrow \mathbb{C}, \quad A \mapsto \det A^t$$

satisfies (A), (B), (C), and (D). □

*Remark.* In particular, all operations on columns of a matrix can be performed on the rows as well and affect the determinant in the same way.

Given  $A \in M_N(\mathbb{C})$  and  $j, k \in \{1, \dots, N\}$ , the  $(N-1) \times (N-1)$ -matrix  $A^{(j,k)}$  is obtained from  $A$  by deleting the  $j$ -th row and the  $k$ -th column.

**Theorem A.2.4.** *For any  $N \times N$ -matrix  $A$ , we have*

$$\det A = \sum_{k=1}^N (-1)^{j+k} a_{j,k} \det A^{(j,k)}$$

for all  $j = 1, \dots, N$  as well as

$$\det A = \sum_{j=1}^N (-1)^{j+k} a_{j,k} \det A^{(j,k)}$$

for all  $k = 1, \dots, N$ .

*Proof.* The right hand sides of both equations satisfy (A), (B), (C), and (D). □

*Example.*

$$\begin{aligned} \det \begin{bmatrix} 1 & 3 & -2 \\ 2 & 4 & 8 \\ 0 & -5 & 1 \end{bmatrix} &= 2 \det \begin{bmatrix} 1 & 3 & -2 \\ 1 & 2 & 4 \\ 0 & -5 & 1 \end{bmatrix} \\ &= 2 \det \begin{bmatrix} 1 & 3 & -2 \\ 0 & -1 & 6 \\ 0 & -5 & 1 \end{bmatrix} \\ &= 2 \det \begin{bmatrix} -1 & 6 \\ -5 & 1 \end{bmatrix} \\ &= 2[-1 + 30] \\ &= 58. \end{aligned}$$

**Corollary A.2.5.** *Let  $T = [t_{j,k}]_{j,k=1,\dots,N}$  be a triangular  $N \times N$ -matrix. Then*

$$\det T = \prod_{j=1}^N t_{j,j}$$

holds.

*Proof.* We use induction on  $N$ . The claim is clear for  $N = 1$ . Let  $N > 1$ , and suppose the claim has been proven for  $N - 1$ . Since  $T^{(1,1)}$  is again a triangular matrix, we conclude from Theorem A.2.4 that

$$\begin{aligned} \det T &= t_{1,1} \det T^{(1,1)} \\ &= t_{1,1} \prod_{j=2}^N t_{j,j}, && \text{by the induction hypothesis,} \\ &= \prod_{j=1}^N t_{j,j}. \end{aligned}$$

This proves the claim. □

**Lemma A.2.6.** *Let  $A, B \in M_N(\mathbb{C})$ . Then  $\det(AB) = (\det A)(\det B)$  holds.*

For the notion of eigenvalue, see the next section in this appendix.

**Theorem A.2.7.** *Let  $A$  be an  $N \times N$ -matrix with eigenvalues  $\lambda_1, \dots, \lambda_N$  (counted with multiplicities). Then*

$$\det A = \prod_{j=1}^N \lambda_j$$

*holds.*

*Proof.* By the Jordan Normal Form Theorem, there are a triangular matrix  $T$  with  $t_{j,j} = \lambda_j$  for  $j = 1, \dots, N$  and an invertible matrix  $S$  such that  $A = STS^{-1}$ . With Lemma A.2.6 and Corollary A.2.5, it follows that

$$\begin{aligned} \det A &= \det(STS^{-1}) \\ &= (\det S)(\det T)(\det S^{-1}) \\ &= (\det SS^{-1}) \det T \\ &= \det T \\ &= \prod_{j=1}^N \lambda_j. \end{aligned}$$

This completes the proof. □

### A.3 Eigenvalues

In analogy with  $M_N(\mathbb{R})$ , we denote by  $M_N(\mathbb{C})$  the  $N \times N$  matrices with complex entries.

**Definition A.3.1.** Let  $A \in M_N(\mathbb{C})$ . Then  $\lambda \in \mathbb{C}$  is called an *eigenvalue* of  $A$  if there is  $x \in \mathbb{C}^N \setminus \{0\}$ —an *eigenvector* of  $A$ —such that  $Ax = \lambda x$ .

**Definition A.3.2.** Let  $A \in M_N(\mathbb{C})$ . Then the *characteristic polynomial*  $\chi_A$  of  $A$  is defined as  $\chi_A(\lambda) := \det(\lambda I_N - A)$ .

**Theorem A.3.3.** *The following are equivalent for  $A \in M_N(\mathbb{C})$  and  $\lambda \in \mathbb{C}$ :*

- (i)  $\lambda$  is an eigenvalue of  $A$ ;
- (ii)  $\chi_A(\lambda) = 0$ .

*Proof.* Note that:

$$\begin{aligned} \lambda \text{ is an eigenvalue of } A &\iff \text{there is } x \in \mathbb{C}^N \setminus \{0\} \text{ such that } Ax = \lambda x \\ &\iff \text{there is } x \in \mathbb{C}^N \setminus \{0\} \text{ such that } \lambda x - Ax = 0 \\ &\iff \lambda I_N - A \text{ has rank strictly less than } N \\ &\iff \det(\lambda I_N - A) = 0. \end{aligned}$$

This proves (i)  $\iff$  (ii). □

*Examples.*

1. Let

$$A = \begin{bmatrix} 3 & 7 & -4 \\ 0 & 1 & 2 \\ 0 & -1 & -2 \end{bmatrix}.$$

It follows that

$$\begin{aligned} \chi_A(\lambda) &= \det \begin{bmatrix} \lambda - 3 & -7 & 4 \\ 0 & \lambda - 1 & -2 \\ 0 & 1 & \lambda + 2 \end{bmatrix} \\ &= (\lambda - 3) \det \begin{bmatrix} \lambda - 1 & -2 \\ 1 & \lambda + 2 \end{bmatrix} \\ &= (\lambda - 3)(\lambda^2 + \lambda - 2 + 2) \\ &= \lambda(\lambda + 1)(\lambda - 3). \end{aligned}$$

Hence, 0,  $-1$ , and 3 are the eigenvalues of  $A$ .

2. Let

$$A = \begin{bmatrix} 0 & 1 \\ -1 & 0 \end{bmatrix},$$

so that  $\chi_A(\lambda) = \lambda^2 + 1$ . Hence,  $i$  and  $-i$  are the eigenvalues of  $A$ .

This last examples shows that a real matrix, need not have real eigenvalues in general.

**Theorem A.3.4** (Spectral Theorem for Symmetric Matrices). *Let  $A \in M_N(\mathbb{R})$  be symmetric, i.e.,  $A = A^t$  where  $A^t$  is the transpose of  $A$ . Then:*

- (i) *all eigenvalues of  $A$  are real;*
- (ii) *there is an orthonormal basis of  $\mathbb{R}^N$  consisting of eigenvectors of  $A$ , i.e., there are  $\xi_1, \dots, \xi_N \in \mathbb{R}$  such that:*
  - (a)  $\xi_1, \dots, \xi_N$  *are eigenvectors of  $A$ ;*
  - (b)  $\|\xi_j\| = 1$  *for  $j = 1, \dots, N$ ;*
  - (c)  $\xi_j \cdot \xi_k = 0$  *for  $j \neq k$ .*

**Definition A.3.5.** Let  $A \in M_N(\mathbb{R})$  be symmetric. Then  $A$  is called:

- (a) *positive definite* if all eigenvalues of  $A$  are positive;
- (b) *negative definite* if all eigenvalues of  $A$  are negative;
- (c) *indefinite* if  $A$  has both positive and negative eigenvalues.

*Remark.* Note that

$$A \text{ is positive definite} \iff -A \text{ is negative definite.}$$

**Theorem A.3.6.** *The following are equivalent for a symmetric matrix  $A \in M_N(\mathbb{R})$ :*

- (i)  *$A$  is positive definite;*
- (ii)  *$Ax \cdot x > 0$  for all  $x \in \mathbb{R}^N \setminus \{0\}$ .*

*Proof.* (ii)  $\implies$  (i): Let  $\lambda \in \mathbb{R}$  be an eigenvalue of  $A$ , and let  $x \in \mathbb{R}^N$  be a corresponding eigenvector. It follows that

$$0 < Ax \cdot x = \lambda x \cdot x = \lambda \|x\|^2,$$

so that  $\lambda > 0$ .

(i)  $\implies$  (ii): Let  $x \in \mathbb{R}^N \setminus \{0\}$ . By Theorem A.3.4,  $\mathbb{R}^N$  has an orthonormal basis  $\xi_1, \dots, \xi_N$  of eigenvectors of  $A$ . Hence, there are  $t_1, \dots, t_N \in \mathbb{R}$ —not all of them zero—such that  $x = t_1\xi_1 + \dots + t_N\xi_N$ . For  $j = 1, \dots, N$ , let  $\lambda_j$  denote the eigenvalue corresponding to the eigenvector  $\xi_j$ . Hence, we have

$$\begin{aligned} Ax \cdot x &= \sum_{j,k} t_j t_k A\xi_j \cdot \xi_k \\ &= \sum_{j,k} t_j t_k \lambda_j (\xi_j \cdot \xi_k) \\ &= \sum_{j=1}^n t_j^2 \lambda_j \\ &> 0, \end{aligned}$$

which proves (i). □

**Corollary A.3.7.** *The following are equivalent for a symmetric matrix  $A \in M_N(\mathbb{R})$ :*

- (i)  $A$  is negative definite;
- (ii)  $Ax \cdot x < 0$  for all  $x \in \mathbb{R}^N \setminus \{0\}$ .

If  $A \in M_N(\mathbb{R})$  is positive definite, then  $\det A > 0$  whereas the converse is clearly false. Still, the following is true:

**Theorem A.3.8** (Hurwitz' Theorem). *A symmetric matrix  $A \in M_N(\mathbb{R})$  as in (A.1) is positive definite if and only if*

$$\det \begin{bmatrix} a_{1,1} & \cdots & a_{1,K} \\ \vdots & \ddots & \vdots \\ a_{K,1} & \cdots & a_{K,K} \end{bmatrix} > 0$$

for all  $K = 1, \dots, N$ .

**Corollary A.3.9.** *A symmetric matrix  $A \in M_N(\mathbb{R})$  is negative definite if and only if*

$$(-1)^{K-1} \det \begin{bmatrix} a_{1,1} & \cdots & a_{1,K} \\ \vdots & \ddots & \vdots \\ a_{K,1} & \cdots & a_{K,K} \end{bmatrix} < 0$$

for all  $K = 1, \dots, N$ .

*Example.* For the symmetric matrix

$$A = \begin{bmatrix} a & b \\ b & d \end{bmatrix},$$

we see that

- $A$  is positive definite if and only if  $a > 0$  and  $ad - b^2 > 0$ ;
- $A$  is negative definite if and only if  $a < 0$  and  $ad - b^2 > 0$ ;
- $A$  is indefinite if and only if  $ad - b^2 < 0$ .

### Exercises

1. Prove the “only if” part of Theorem A.3.8.
2. Let  $\begin{bmatrix} a & b \\ b & d \end{bmatrix} \in M_2(\mathbb{R})$  be such that  $a > 0$  and  $ad - b^2 > 0$ . Show that  $A$  is positive definite. (*Hint:* Take a look at  $\chi_A(\lambda)$  from two different perspectives.)

## Appendix B

# Limit Superior and Limit Inferior

### B.1 The Limit Superior

**Definition B.1.1.** A number  $a \in \mathbb{R}$  is called an *accumulation point* of a sequence  $(a_n)_{n=1}^{\infty}$  if there exists a subsequence  $(a_{n_k})_{k=1}^{\infty}$  of  $(a_n)_{n=1}^{\infty}$  such that  $\lim_{k \rightarrow \infty} a_{n_k} = a$ .

If  $(a_n)_{n=1}^{\infty}$  is convergent with limit  $a$ , then  $a$  is the only accumulation point of  $(a_n)_{n=1}^{\infty}$ . It is possible that  $(a_n)_{n=1}^{\infty}$  has only one accumulation point, but nevertheless does not converge: for  $n \in \mathbb{N}$ , let

$$a_n := \begin{cases} n, & n \text{ odd,} \\ 0, & n \text{ even.} \end{cases}$$

Then 0 is the only accumulation point of  $(a_n)_{n=1}^{\infty}$ , even though the sequence is unbounded and thus not convergent. On the other hand, we have:

**Proposition B.1.2.** *Let  $(a_n)_{n=1}^{\infty}$  be a bounded sequence in  $\mathbb{R}$  which only has one accumulation point, say  $a$ . Then  $(a_n)_{n=1}^{\infty}$  is convergent with limit  $a$ .*

*Proof.* Assume otherwise. Then there exists  $\epsilon_0 > 0$  and a subsequence  $(a_{n_k})_{k=1}^{\infty}$  of  $(a_n)_{n=1}^{\infty}$  with  $|a_{n_k} - a| \geq \epsilon_0$ . Since  $(a_{n_k})_{k=1}^{\infty}$  is bounded, it has—by the Bolzano–Weierstraß Theorem—a convergent subsequence  $(a_{n_{k_j}})_{j=1}^{\infty}$  with limit  $a'$ . Since  $|a - a'| \geq \epsilon_0$ , we have  $a' \neq a$ . On the other hand,  $(a_{n_{k_j}})_{j=1}^{\infty}$  is also a subsequence of  $(a_n)_{n=1}^{\infty}$ , so that  $a'$  is also an accumulation point of  $(a_n)_{n=1}^{\infty}$ . Since  $a' \neq a$ , this is a contradiction.  $\square$

**Proposition B.1.3.** *Let  $(a_n)_{n=1}^{\infty}$  be a bounded sequence in  $\mathbb{R}$ . Then the set of accumulation points of  $(a_n)_{n=1}^{\infty}$  is non-empty and bounded.*

*Proof.* By the Bolzano–Weierstraß Theorem,  $(a_n)_{n=1}^{\infty}$  has at least one accumulation point.

Let  $a$  be any accumulation point of  $(a_n)_{n=1}^{\infty}$ , and let  $C \geq 0$  be such that  $|a_n| \leq C$  for  $n \in \mathbb{N}$ . Let  $(a_{n_k})_{k=1}^{\infty}$  be a subsequence of  $(a_n)_{n=1}^{\infty}$  such that  $a = \lim_{k \rightarrow \infty} a_{n_k}$ . It follows that  $|a| = \lim_{k \rightarrow \infty} |a_{n_k}| \leq C$ .  $\square$

**Definition B.1.4.** Let  $(a_n)_{n=1}^\infty$  be bounded below. If  $(a_n)_{n=1}^\infty$  is bounded, define the *limit superior*  $\limsup_{n \rightarrow \infty} a_n$  of  $(a_n)_{n=1}^\infty$  by letting

$$\limsup_{n \rightarrow \infty} a_n := \sup\{a \in \mathbb{R} : a \text{ is an accumulation point of } (a_n)_{n=1}^\infty\};$$

otherwise, let  $\limsup_{n \rightarrow \infty} a_n := \infty$ .

Of course, if  $(a_n)_{n=1}^\infty$  converges, we have  $\limsup_{n \rightarrow \infty} a_n = \lim_{n \rightarrow \infty} a_n$ .

**Proposition B.1.5.** *Let  $(a_n)_{n=1}^\infty$  be bounded below. Then there exists a subsequence  $(a_{n_k})_{k=1}^\infty$  of  $(a_n)_{n=1}^\infty$  such that  $\limsup_{n \rightarrow \infty} a_n = \lim_{k \rightarrow \infty} a_{n_k}$ .*

*Proof.* If  $\limsup_{n \rightarrow \infty} a_n = \infty$ , the claim is clear (since  $(a_n)_{n=1}^\infty$  is not bounded above, there has to be a subsequence converging to  $\infty$ )

Suppose that  $a := \limsup_{n \rightarrow \infty} a_n < \infty$ . there exists an accumulation point  $p_1$  of  $(a_n)_{n=1}^\infty$  such that  $|a - p_1| < \frac{1}{2}$ . From the definition of an accumulation point, we can find  $n_1 \in \mathbb{N}$  such that  $|p_1 - a_{n_1}| < \frac{1}{2}$ , so that

$$|a - a_{n_1}| \leq |a - p_1| + |p_1 - a_{n_1}| < 1.$$

Suppose now that  $n_1 < \dots < n_k$  have already been found such that

$$|a - a_{n_j}| < \frac{1}{j}$$

for  $j = 1, \dots, k$ . Let  $p_{k+1}$  be an accumulation point of  $(a_n)_{n=1}^\infty$  such that  $|a - p_{k+1}| < \frac{1}{2(k+1)}$ . By the definition of an accumulation point, there exists  $n_{k+1} > n_k$  such that  $|p_{k+1} - a_{n_{k+1}}| < \frac{1}{2(k+1)}$ , so that

$$|a - a_{n_{k+1}}| \leq |a - p_{k+1}| + |p_{k+1} - a_{n_{k+1}}| < \frac{1}{k+1}.$$

Inductively, we thus obtain a subsequence  $(a_{n_k})_{k=1}^\infty$  of  $(a_n)_{n=1}^\infty$  such that  $a = \lim_{k \rightarrow \infty} a_{n_k}$ . □

*Example.* It is easy to see that

$$\limsup_{n \rightarrow \infty} n(1 + (-1)^n) = \infty \quad \text{and} \quad \limsup_{n \rightarrow \infty} (-1)^n \left(1 + \frac{1}{n}\right)^n = e.$$

The following is easily checked:

**Proposition B.1.6.** *Let  $(a_n)_{n=1}^\infty$  and  $(b_n)_{n=1}^\infty$  be bounded below, and let  $\lambda, \mu \geq 0$ . Then*

$$\limsup_{n \rightarrow \infty} (\lambda a_n + \mu b_n) \leq \lambda \limsup_{n \rightarrow \infty} a_n + \mu \limsup_{n \rightarrow \infty} b_n$$

*holds.*

The scalars in this proposition have to be non-negative, and in general, we cannot expect equality:

$$0 = \limsup_{n \rightarrow \infty} ((-1)^n + (-1)^{n-1}) < 2 = \limsup_{n \rightarrow \infty} (-1)^n + \limsup_{n \rightarrow \infty} (-1)^{n-1}.$$

## B.2 The Limit Inferior

Paralell to the limit superior, there is a limit inferior:

**Definition B.2.1.** Let  $(a_n)_{n=1}^{\infty}$  be bounded above. If  $(a_n)_{n=1}^{\infty}$  is bounded, define the *limit inferior*  $\liminf_{n \rightarrow \infty} a_n$  of  $(a_n)_{n=1}^{\infty}$  by letting

$$\liminf_{n \rightarrow \infty} a_n := \inf\{a \in \mathbb{R} : a \text{ is an accumulation point of } (a_n)_{n=1}^{\infty}\};$$

otherwise, let  $\liminf_{n \rightarrow \infty} a_n := -\infty$ .

As for the limit superior, we have that, if  $(a_n)_{n=1}^{\infty}$  converges, we have  $\liminf_{n \rightarrow \infty} a_n = \lim_{n \rightarrow \infty} a_n$ .

Also, as for the limit superior, we have:

**Proposition B.2.2.** *Let  $(a_n)_{n=1}^{\infty}$  be bounded above. Then there is a subsequence  $(a_{n_k})_{k=1}^{\infty}$  of  $(a_n)_{n=1}^{\infty}$  such that  $\liminf_{n \rightarrow \infty} a_n = \lim_{k \rightarrow \infty} a_{n_k}$ .*

If  $(a_n)_{n=1}^{\infty}$  is bounded, then  $\limsup_{n \rightarrow \infty} a_n$  and  $\liminf_{n \rightarrow \infty} a_n$  both exist. Then, by definition,

$$\liminf_{n \rightarrow \infty} a_n \leq \limsup_{n \rightarrow \infty} a_n$$

holds with equality if and only if  $(a_n)_{n=1}^{\infty}$  converges.

Furthermore, if  $(a_n)_{n=1}^{\infty}$  is bounded below, then

$$\liminf_{n \rightarrow \infty} (-a_n) = -\limsup_{n \rightarrow \infty} a_n$$

holds, as is straightforwardly verified. (An analogous statement holds for  $(a_n)_{n=1}^{\infty}$  bounded above.)



# Index

- 1-form, 202
- Abel's Summation by Parts, 246
- Abel's Theorem, 278
- absolutely convergent
  - improper Riemann integral, 259
  - infinite series, 245
- accumulation point, 310
- admissible parameter transformation, 199
- affine  $r$ -chain, 232
- alternating
  - $r$ -linear form, 216
  - harmonic series, 248
- alternating 2-form, 203
- alternating series, 246
- Alternating Series Test, 247
- angle between two curves, 172
- antiderivative, 113
- Archimedean field, 15
- associativity, 8
- axioms
  - field, 8
  - order, 11
- Baby Inverse Function Theorem, 138
- ball
  - closed, 28
  - open, 28
- Banach's Fixed Point Theorem, 65
- Bernoulli's Inequality, 54
- Bessel's Inequality, 287
- bijective map, 21
  - inverse of, 21
- binomial series, 281
- Bolzano–Weierstraß Theorem, 36
- bound
  - lower, 14
  - upper, 14
- boundary
  - of a set, 38
  - point, 38
  - positively oriented, 191, 193
- bounded
  - sequence, 49
  - set, 14, 36
    - above, 14
    - below, 14
- bounded variation, 247
- $\mathcal{C}^0$ -function, 133
- $\mathcal{C}^1$ -
  - curve, 168
    - piecewise, 175
  - parameter transformation, 174
    - orientation preserving, 174
    - orientation reversing, 174
- Cantor's Diagonal Argument, 24
- cardinality, 22

- Cartesian product, 24
- Cauchy
  - Criterion
    - for improper Riemann integrals, 259
    - for infinite series, 245
    - for Riemann Integrability, 103
  - Product Formula, 254
  - sequence, 53
    - uniform, 269
- Cauchy–Hadamard Formula, 275
- Cauchy–Schwarz Inequality, 26
- Cavalieri’s Principle, 120
- Chain Rule, 68, 82
- Change of Variables, 123, 151
  - in one variable, 114
- characteristic polynomial, 307
- Clairaut’s Theorem, 73
- closed
  - ball, 28
  - curve, 182
  - differential form, 228
  - interval, 17
  - set, 33
- closure of a set, 39
- cluster point, 35
- co-domain, 20
- commutativity, 8
- compact
  - $N$ -dimensional interval, 97
    - partition of, 100
    - subdivision of, 100
  - set, 41
- Comparison Test
  - for improper Riemann integrals, 260
  - for infinite series, 248
  - Limit, 249
- concatenation, 177
  - of two curves, 175
- conditionally convergent
  - infinite series, 246
- connected set, 43
- conservative vector field, 181
- content, 107
  - of a compact  $N$ -dimensional interval, 97
  - set with, 107
  - zero, 97
- continuous function, 58
  - at  $x_0$ , 56
- continuously partially differentiable
  - function, 73
  - twice, 73
- convergence
  - locally uniform, 272
  - pointwise, 267
  - uniform, 267
- convergent
  - sequence, 48
  - series, 243
- convex set, 28
- coordinates, 24
  - cylindrical, 128
  - polar, 125
  - spherical, 127
- countable set, 23
- $C^p$ -function, 133
- cross product, 197
- cube, 152
  - with center  $x$  and side length  $2r$ , 157
- curl, 76
- curve, 166
  - $C^1$ -, 168
    - piecewise, 175
  - closed, 182
  - functional, 202

- integral
  - properties of, 177
- integral of a vector field, 177
- length of, 168
- level, 137
- line element of, 166
- piecewise continuously
  - differentiable, 175
- rectifiable, 168
- regular, 172
- regular at a point, 172
- singular at a point, 172
- tangent vector to, 172
- trace of, 166
- cycloid, 170
- cylindrical coordinates, 128
- decreasing sequence, 51
- derivative
  - first, 66
  - left-hand, 288
  - partial
    - first, 70
    - higher order, 72
    - second, 72
  - right-hand, 289
- determinant, 303
- differentiable function, 68
  - at  $x_0$ , 79
- differential
  - $r$ -form, *see* differential form
  - form, 221
    - closed, 228
    - exact, 228
    - of class  $C^p$ , 221
    - outer differential of, 223
    - pullback of, 226
    - standard representation of, 222
    - surface integral of, 228
  - of a  $C^1$ -function, 223
  - of a totally differentiable function, 80
  - outer
    - of a differential form, 223
- Dini's Lemma, 271
- directional derivative, 83
- Dirichlet kernel, 287
- Dirichlet Test, 247
- disconnected set, 43
- disconnection of a set, 43
- discrete set, 63
- distributivity, 8
- divergence, 76
- divergent sequence, 48
- domain, 20
- dot product, 25
- eigenvalue, 306
- eigenvector, 306
- elements
  - inverse
    - existence of, 8
    - uniqueness of, 10
  - neutral
    - existence of, 8
    - uniqueness of, 10
- equation
  - heat, 78
  - potential, 77
  - wave, 77
- Euclidean
  - norm, 25
  - space, 24
- Euler's Identity, 281
- exact differential form, 228
- existence
  - of inverse elements, 8
  - of neutral elements, 8

- extremum
  - local, 68, 72
  - under the constraint  $\phi(x) = 0$ , 145
- field, 8
  - Archimedean, 15
  - axioms, 8
  - ordered, 11
    - complete, 14
- finite intersection property, 46
- first
  - derivative, 66
    - partial, 70
- First Derivative Test, 72
- form
  - $r$ -linear, 216
    - alternating, 216
- Fourier
  - coefficients, 282
  - complex, 296
  - series, 283
- Fubini's Theorem, 116
- function, *see* map
  - $\mathcal{C}^0$ -, 133
  - continuous, 58
    - at  $x_0$ , 56
  - $\mathcal{C}^p$ -, 133
  - differentiable, 68
    - at  $x_0$ , 79
  - harmonic, 77
  - indicator, 108
  - limit for  $x \rightarrow x_0$  of, 55
  - Lipschitz continuous, 65
  - locally injective, 133
  - of class  $\mathcal{C}^0$ , 133
  - of class  $\mathcal{C}^p$ , 133
  - partially differentiable, 72
    - at  $x_0$ , 70
    - continuously, 73
  - piecewise
    - continuously differentiable, 290
    - differentiable, 290
    - linear, 290
  - Riemann integrable, 102, 107
  - uniformly continuous, 63
- Fundamental Theorem
  - for Curve Integrals, 181
  - of Calculus, 113
- Gamma Function, 266
- Gauß' Theorem, 213
- geometric series, 244
- Geometric versus Arithmetic Mean, 26
- gradient, 71
  - field, 76, 181
- Green's
  - First Formula, 215
  - Second Formula, 215
  - Theorem, 193
- harmonic
  - function, 77
  - series, 244
    - alternating, 248
- heat equation, 78
- Heine–Borel Theorem, 42
- Hessian of  $f$ , 90
- higher order partial derivative, 72
- Hurwitz' Theorem, 309
- image, 20
- Implicit Function Theorem, 140
- improper Riemann integral, 258
  - absolutely convergent, 259
- increasing sequence, 51
- indefinite matrix, 92, 308
- indicator function, 108
- inequality
  - Cauchy–Schwarz, 26

- triangle, 27
- infimum, 14
- injective map, 21
- integrable function, *see* Riemann
  - integrable function
- integral, *see* Riemann integral
  - of a vector field along a curve, 177
- Integral Comparison Test, 263
- Integration by Parts, 115
- interior
  - of a set, 40
  - point, 40
- Intermediate Value Theorem, 61
- interval
  - closed, 17
  - compact  $N$ -dimensional, 97
    - content of, 97
    - partition of, 100
    - subdivision of, 100
  - open, 17
- inverse
  - elements
    - existence of, 8
    - uniqueness of, 10
  - image, 20
  - map, 21
- Inverse Function Theorem, 140
  - Baby, 138
- isolated point, 62
- Jacobian matrix, 80
- Jordan content, *see* content
- Lagrange
  - multiplier, 145
- Lagrange Multiplier Theorem, 145
- Laplace operator, 77
- Law of Conservation of Energy, 181
- left-hand derivative, 288
- length, 168
- level curve, 137
- Limit
  - Comparison Test, 249
  - Ratio Test, 250
  - Root Test, 251
- limit
  - inferior, 312
  - of a function for  $x \rightarrow x_0$ , 55
  - of a sequence as  $n \rightarrow \infty$ , 48
  - superior, 311
- Limit Rules, 50
- line
  - element, 166
  - segment, 166
- linear map, 300
- Lipschitz continuous function, 65
- local
  - extremum, 68, 72
    - under the constraint  $\phi(x) = 0$ , 145
  - maximum, 68, 72
    - under the constraint  $\phi(x) = 0$ , 145
  - minimum, 68, 72
    - under the constraint  $\phi(x) = 0$ , 145
- locally injective function, 133
- lower bound, 14
- map, 20
  - bijjective, 21
    - inverse of, 21
  - co-domain of, 20
  - domain of, 20
  - injective, 21
  - linear, 300
  - range of, 20
  - surjective, 21
- mapping, *see* map
- matrix
  - indefinite, 92, 308

- Jacobian, 80
- negative definite, 92, 308
- positive definite, 92, 308
- symmetric, 308
- maximum
  - global, 96
  - local, 68, 72
    - under the constraint  $\phi(x) = 0$ , 145
- Mean Value Theorem, 69
- minimum
  - global, 95
  - local, 68, 72
    - under the constraint  $\phi(x) = 0$ , 145
- monotone sequence, 51
- multiindex, 88
- negative definite matrix, 92, 308
- neighborhood, 31
- Nested Interval Property, 17, 30
- neutral elements
  - existence of, 8
  - uniqueness of, 10
- norm
  - Euclidean, 25
  - operator, 301
- normal
  - domain in  $\mathbb{R}^2$ , 193
    - with respect to the  $x$  axis, 189
    - with respect to the  $y$  axis, 192
  - domain in  $\mathbb{R}^3$ , 213
    - with respect to the  $xy$ -plane, 210
  - vector, 198
  - unit, 205
- open
  - ball, 28
  - cover, 41
  - interval, 17
  - set, 32
- operator norm, 301
- order axioms, 11
- ordered field, 11
  - complete, 14
- oriented
  - $r$ -simplex, 232, 233
    - affine  $r$ -simplex, 231, 232
  - boundary
    - of an affine oriented  $r$ -simplex, 232
    - of an oriented  $r$ -simplex, 233
- origin, 24
- orthonormal basis, 308
- outer differential, 223
- parameter domain
  - of a surface
    - in  $\mathbb{R}^3$ , 196
    - in  $\mathbb{R}^N$ , 228
- parameter transformation
  - admissible, 199
- Parseval's Identity, 296
- partial derivative, 70
  - first, 70
  - higher order, 72
  - second, 72
- partial sums of a series, 243
- partially differentiable function, 72
  - at  $x_0$ , 70
- partition, 100
  - refinement of, 101
  - subdivision generated by, 100
- path connected set, 62
- permutation, 217, 303
  - even, 231
  - odd, 231
  - sign of, 303
- piecewise
  - $\mathcal{C}^1$  curve, 175

- continuously differentiable function, 290
- differentiable function, 290
- linear function, 290
- point, 24
  - coordinates of, 24
  - stationary, 91
- pointwise convergence, 267
- polar coordinates, 125
- polygonal path, 166
- positive definite matrix, 92, 308
- positively oriented boundary, 191, 193
- potential
  - equation, 77
  - function, 181
- power series, 272
- power set, 24
- pullback of a differential form, 226
- $r$ -chain, 233
  - trace of, 233
- $r$ -form, *see* differential form
- $r$ -linear form, 216
  - alternating, 216
- $r$ -simplex
  - equivalent, 233
  - oriented, 232, 233
    - oriented boundary of, 233
  - oriented affine, 231, 232
    - equivalent, 231
    - oriented boundary of, 232
    - vertices of, 231
- $r$ -surface in  $\mathbb{R}^N$ , 228
- radius of convergence, 273
- range, 20
- rank, 134
- Ratio Test, 249
  - Limit, 250
- real numbers, 8
- rectifiable curve, 168
- refinement, 101
  - common, 102
- Riemann
  - integrable function, 102, 107
  - integral, 102
    - improper, 258
  - sum, 101
- Riemann's Rearrangement Theorem, 252
- Riemann–Lebesgue Lemma, 288
- right-hand derivative, 289
- Rolle's Theorem, 69
- Root Test, 250
  - Limit, 251
- Rules of Differentiation, 67
- saddle point, 91
- scalar, 25
- Second Derivative Test, 87, 93
  - in one variable, 87
- second partial derivative, 72
- sequence, 48
  - bounded, 49
  - Cauchy, 53
  - converget, 48
  - decreasing, 51
  - divergent, 48
  - increasing, 51
  - monotone, 51
  - subsequence of, 50
- series, 243
  - Abel's Summation by Parts, 246
  - absolutely convergent, 245
  - alternating, 246
  - binomial, 281
  - conditionally convergent, 246
  - convergent, 243
  - expansion, 276
  - Fourier, 283

- geometric, 244
- harmonic, 244
  - alternating, 248
- partial sums of, 243
- power, 272
- Taylor, 277
- set
  - bounded, 14, 36
    - above, 14
    - below, 14
  - closed, 33
  - closure of, 39
  - compact, 41
  - connected, 43
  - convex, 28
  - countable, 23
  - disconnected, 43
  - discrete, 63
  - open, 32
  - path connected, 62
  - star shaped, 46, 187
  - with content, 107
  - with content zero, 97
- sign of a permutation, 217, 303
- Spectral Theorem for Symmetric
  - Matrices, 308
- sphere, 38
- spherical coordinates, 127
- standard representation of a differential
  - form, 222
- star shaped set, 46, 187
- stationary point, 91
- Stokes' Theorem, 205
  - for differential forms, 240
- subdivision, 100
- subsequence of a sequence, 50
- Summation by Parts, 246
- summation by parts, 246
- supremum, 14
- surface
  - area, 198
  - element
    - in  $\mathbb{R}^3$ , 196
    - in  $\mathbb{R}^N$ , 228
  - of an  $r$ -chain, 233
  - functional, 203
  - in  $\mathbb{R}^3$ , 196
    - parameter domain of, 196
  - in  $\mathbb{R}^N$ 
    - parameter domain of, 228
  - integral
    - of a differential form, 228
    - of a function, 204
    - of a vector field, 204
- surjective map, 21
- symmetric matrix, 308
- tangent vector, 172
- Taylor
  - expansion, 277
  - series, 277
- Taylor's Theorem, 89
  - in one variable, 87
- trace
  - of a curve, 166
  - of a surface in  $\mathbb{R}^3$ , 196
  - of a surface in  $\mathbb{R}^N$ , 228
  - of an  $r$ -chain, 233
- transpose, 308
- transposition, 217
- triangle inequality, 18, 27
- trigonometric polynomial, 285
- twice continuously partially
  - differentiable function, 73
- uniform
  - Cauchy sequence, 269



- continuity, 63
- convergence, 267
  - local, 272
- uniformly continuous function, 63
- uniqueness
  - of inverse elements, 10
  - of neutral elements, 10
  - of the limit, 48
- unit
  - simplex, 231
  - vector, 83
- upper bound, 14
- vector
  - coordinates of, 24
  - field, 76
    - conservative, 181
  - space, 25
  - zero, 24
- wave equation, 77
- wedge product, 203
  - of alternating multilinear forms, 220
  - of differential forms, 222
- Weierstraß
  - $M$ -Test, 270, 299
  - Approximation Theorem, 293
- zero vector, 24